



Heartland
AG SYSTEMS

Heartland Agriculture, LLC

PRESENTS

THE

1612

SERIES

TENDERS

**OPERATOR'S MANUAL
AND PARTS LIST
OM-1612**

HEARTLAND AG SYSTEMS
1180 STATE HWY 7 EAST
HUTCHINSON, MN. 55350
(320) 587-4030

ISSUE
SEPTEMBER 2023

WARRANTY REGISTRATION

TO THE DEALER:

Inspect the implement thoroughly after assembly to be certain it is functioning properly before delivering it to the customer. Check off each item as it is found satisfactory or after proper adjust is made.

PRE -DELIVERY CHECKLIST

- _____ 1. All hardware properly tightened.
- _____ 2. Lubrication of grease fittings.
- _____ 3. All decals properly located and readable.
- _____ 4. Other adjustments, "level operation", "drawbar height", etc.
- _____ 5. Proper tongue weight after all options are mounted. Adjustments made if required.
- _____ 6. Overall condition. Touch-up paint any scratches. Clean and polish
- _____ 7. Operator's manual.

Review the operator's manual with the customer. Explain the following:

- _____ 1. Safe operation and service
- _____ 2. Correct machine installation and operation.
- _____ 3. Correct and periodic lubrication and maintenance.
- _____ 4. Daily and periodic inspection.
- _____ 5. Troubleshooting.
- _____ 6. Storing machine.
- _____ 7. Heartland AG Systems parts and service
- _____ 8. Have the customer write the machine model and serial number in the space provided in the manual introduction
- _____ 9. Give the customer the operator's manual and encourage the customer to read the manual carefully.

Seller Information

Date set-up _____
 Signature _____
 Dealer name _____
 Address _____
 City, state, zip _____
 Phone _____

Customer Information

Date delivered _____
 Customer name _____
 Customer address _____
 Signature _____
 Model number _____
 Serial number _____

PLEASE FILL OUT THIS SHEET AND RETURN TO HEARTLAND AG SYSTEMS

1180 State Highway 7 East Hutchinson, MN 55350

www.heartlandag.com | Heartland Agriculture, LLC dba Heartland AG Systems

1612 SERIES TENDER
CONTENTS

1612CNTS
11/9/20

To the Owner	2
Warranty	W1-8
Warnings, Danger, Caution	5
Safety Instructions	6 to 17
Safety Decals	18 to 22
Operating & Service	23 to 26
Maintenance & Servicing	27 & 29
Care of Machine	30 & 31
Specifications	32 to 35
Box and Bolt-On Parts (Std box Fall 2010 and Newer)	36 & 37
OPTIONAL Catwalk and Safety bar parts	37A-37D
Std box Slidegate Crank System Parts Illustration	38 & 39
Std box Slidegate Crank System Installation Instructions	40
Box and Bolt-On Parts (Std box 2004 thru Spring 2010)	41 & 42
Box and Bolt-On Parts (3 comp't box 2010 & older)	43 & 44
Box and Bolt-On Parts (3 comp't box 2011 & newer)	45 & 46
3 comp. box Slidegate Crank System Parts Illustration	47 & 48
Rear Discharge Auger Parts illustration	49 & 50
Hydraulic System Schematic & Parts Listing	51
Hydraulic Cylinder Parts and Cyl Disassembly/Assembly	52
Wiring diagram (Light Kit Parts)	53
Vibrator parts	55-66

TO THE OWNER

Congratulations on your selection of the Heartland AG Systems Tender.

The Heartland AG Systems Tender has been designed to provide years of profitable and dependable service. To assure maximum performance of your Tender it is mandatory that you thoroughly study the operator's manual and follow its recommendations. Proper operation and maintenance are essential for safety and to maximize machine life.

It is the owner, manager, and/or operators' responsibility to:

Operate and maintain this tender in a safe manner and in accordance with all applicable local, state, and federal codes and or laws; and in compliance with labeling instructions by the supplier of the chemicals being used.

Make sure each and every operator has read this manual and thoroughly understands safe and correct operating procedure.

Make sure unauthorized people neither operate the Tender nor are in the vicinity of the Tender while it is in operation.

Make sure the Tender is maintained to preserve and/or improve safety, accuracy, and reliability of the system. Read and follow the maintenance schedule in this manual. Furthermore, as additional technology becomes available, the owner is responsible for improving the safety, accuracy, and reliability of the Tender.

Fulfill all warranty obligations so as not to void the warranties. The warranty information on the following pages outlines the warranty policy of Heartland AG Systems and its suppliers.

Heartland Ag Systems, dba Heartland Agriculture, LLC reserves the right to make product improvements to the equipment at any time. Heartland AG Systems shall not be obligated to make such changes to the machines already in service.

Warranty Policies and Terms

The Heartland Agriculture, LLC warranty is a limited warranty that is provided to the retail purchaser in return for consideration paid as part of the purchase price for a product. The selling dealer must review the warranty coverage with the retail purchaser and obtain a signature on the Operators Manual for warranty verification.

The warranty described here is for Heartland Agriculture, LLC doing business as Heartland AG Systems and its product line Heartland AG Systems Equipment sold and registered in the United States and Canada and normally operated in the United States and Canada.

Warranty Period

The warranty period for all coverage begins at the time that any person, dealer or agent first places the unit into service. At the latest, a unit is placed into service when purchased or delivered to a purchaser.

What's Covered

If a defect in material or workmanship is found in a unit and reported during the Warranty period, Heartland AG Systems will pay parts and labor costs to repair the defects if the services are performed by an authorized Heartland AG Systems dealer. If parts are needed during the repair, Heartland AG Systems will, at its option, use genuine Heartland AG Systems, or remanufactured parts.

Heartland AG Systems provides no warranty, express or implied, for a component or other item that is separately warranted to the purchaser by its manufacturer, such as tires. Check with your local dealer for these details.

Exclusive Remedy

The remedy of repairing a defect in material or workmanship at a Heartland AG Systems dealership under the terms of this warranty is the purchaser's exclusive remedy and is in lieu of any other remedy otherwise available.

No Modification or Extension of Warranty

The Heartland AG Systems Warranty is limited to the written terms in the warranty statement. Heartland AG Systems does not authorize any person, dealer, or agent to change or extend the terms of this warranty in any manner. Any assistance to the purchaser in the repair or operation of any Heartland AG Systems product outside the terms or limitations or exclusions of this warranty will not constitute a waiver of the terms, limitations or exclusions of this warranty, nor will such assistance extend or re-establish the warranty.

The warranty is void if the unit is used in an application for which it is not designed or the unit has been scrapped, salvaged, stolen, junked or totaled.

Limitations and Exclusions

The Heartland AG Systems warranty gives you specific legal rights and you may also have other rights, which vary from state to state. This section contains the entire Heartland AG Systems warranty. Heartland AG Systems makes no other representations or warranties, expressed or implied, and specifically excludes the implied warranties of merchantability and fitness for particular purpose. Heartland AG Systems will not be liable for incidental or consequential damages resulting from a breach of the written warranty or any implied warranty.

- These limitations and exclusions may not be allowed by some states or provinces and shall not apply to the extent such limitations or exclusions are not allowed by applicable state/provincial law.

Owner's Responsibility

The Heartland AG Systems Warranty remains in effect during the warranty period if the owner performs the required maintenance at the recommended intervals outlined in the product's operator's manual and the unit is operated within its rated capacity. Genuine Heartland AG Systems service parts or Heartland AG Systems approved service parts that meet Heartland AG Systems specifications must be used for maintenance and repairs.

What Is Not Covered

- Replacement of non-defective wear items expected to be replaced during the warranty period, including, but not limited to: lights, fuses, belts, drive sprockets and chains, hose, soil engaging tools, spray tips, fertilizer deflectors, spinner blades and accessories or items replaced due to customer demand.
- Normal maintenance parts and service, including, but not limited to lubrication, coolants, and filters.
- All travel costs associated with hauling or towing a customer's machine to and from a repair center related to any warranty repair unless specifically covered by a program or policy.
- Repairs arising from any unauthorized modification to the product.
- Repairs arising from service performed by agents not approved by Heartland AG Systems.
- Repairs arising from storage deterioration, failure to maintain the equipment, improper use of the equipment, collision or other accident, vandalism, or other casualty, or operation beyond the rated capacity or specifications.
- Repairs arising from abuse or neglect including, but not limited to operation without adequate lubricants or coolant, over-speeding, contaminated fluids, improper storage, starting, warm-up, or shutdown practices.
- Failure of the machine, its implements or attachments caused by improper field application or overloading.
- Premiums charged for over-time labor costs.
- Economic loss, including lost profits, crop loss, equipment rental or other expenses.
- Cost associated with cleaning of machine in preparation for service.
- Loss or damage during shipment.

- Cost of initial setup or installation of any optional equipment or attachments to a unit.
- Items used for repairs include, but are not limited to: solvents, cleaners, anti-seize lubricants, oil-dry, shop towels, shop supplies, special tools, etc.
- Included, but not limited to are checkups, adjustments, and shimming, tune-ups, spread pattern checks, etc.
- Unauthorized modification or field fixes.
- All costs of special tools or shop supplies incurred with repairs.
- Claims for stolen equipment or parts.
- Claims for replacing a complete assembly when the repair is less than the replacement.
- Claims involving the inspection or reconditioning of units.
- Shop comebacks: any duplicate, repeat, or comeback repair resulting from improper diagnosis, testing, or poor service work.
- Cost of removing or installing Non-Heartland AG Systems optional equipment or attachments.

Base Warranty Coverage

- Base Warranty is the factory warranty provided to the customer at no additional cost for a specific period covering the complete machine.

• Liquid Applicators, except tires	1 Year
• Spreaders and Tenders, except tires	1 Year
• Nh3 Wagons, except tires	1 Year
• Bumper Hitches	1 Year
• Disc Covers	1 Year
• Parts	90 Days
• Tandem Wagons (except tires and main frame)	1 year
o Tandem Wagon main frame	5 Years
• Nitromaster Toolbars shall carry the following pro-rated warranty:	
o Year one, all components except tires	100%
o Year two, center section and wings	80%
o Year three, center section and wings	50%
o Year four, center section and wings	25%
o Year five, center section and wings	10%

Tires

Tires installed on all Heartland AG Systems Equipment are warranted and serviced by their manufacturer's service outlets. Some manufacturers have separate service outlets for off road agricultural and construction equipment. Service is available by contacting the tire manufacturer's local representative.

Warranty Registration

All machinery items, which are invoiced by Heartland AG Systems on separate receivables, must be registered for warranty. The warranty period for all coverage begins at the time that any person, dealer, or agent first places the unit into service. New machine warranty coverage begins when the machine is registered. Registration is accomplished when a properly completed Warranty Registration is received and processed by Heartland AG Systems.

Operator's Manual/Warranty Receipt Verification

The Heartland AG Systems New Equipment Limited Warranty for Agricultural Equipment statement must be filled out and signed by the customer indicating receipt and an understanding of the operator's manual and the warranty statement,

- The original form must be mailed to the address on the form.
- Make one copy for the Dealer. This copy must be retained by your dealership the same as any other legal document.
- Make a second copy for the customer.

Heartland AG Systems Responsibility

If a defect in material or workmanship is found in a product during its warranty period, Heartland AG Systems will pay parts and labor costs to repair the defect when the service is performed by an authorized Heartland AG Systems dealer or agent. If parts are needed during the repair, Heartland AG Systems will, at its option, use genuine Heartland AG Systems new or remanufactured parts. These responsibilities include, but are not limited to:

- Costs for repairs that are the result of defects in material and workmanship
- Payment to dealers per policy in a timely manner
- Service information to dealers
- Identify product deficiencies and take corrective action by field campaigns
- Make determination of premature wear
- Provide unit that is free of defects in material & workmanship

Dealer Responsibility

Heartland AG Systems dealers are responsible for providing prompt, courteous, and willing service to all Heartland AG Systems equipment owners. These responsibilities include but are not limited to:

- Equipment set-up and pre-delivery
- Sell the right product for the intended application
- Inspect the unit and initiate recovery action on any shipping damage and or shortages
- Instruct customer on proper use, maintenance, and safety features of machine
- Advise and explain warranty coverage to customer
- Diagnose the problem, repair the unit, and submit claims in accordance with the terms and conditions of the warranty claim policies
- Take responsibility for saying "NO" to customers on non-warranty failures
- Apply failure analysis to questionable repairs
- Complete product update campaigns
- Have properly trained technicians and adequate tools for the job
- Retain proper documentation of failure repaired

Owners Responsibility

The Heartland AG Systems warranty remains in effect during the stated warranty period if the owner performs the required maintenance at the recommended times as outlined in the products operator's manual. Genuine Heartland AG Systems or Heartland AG Systems approved service parts must be used for maintenance. Additionally, the owner will pay for all transportation or travel expenses related to any warranty repair.

These responsibilities include, but are not limited to:

- Perform maintenance as indicated in the operator's manual
- Use the unit in the correct application (non-abusive)
- Notify dealer of failures and have the machine available for repair in a timely manner
- Training operators
- Travel cost, towing charges, and service calls
- Normal wear items
- Machine damage (accidental)
- Adjustments for application
- Machine inspection (daily walk-around)

Warranty Eligibility

The dealer is responsible to determine that any Heartland AG Systems equipment is covered by Heartland AG Systems warranty before performing a repair and that the repair is a warrantable failure. Any dealer who is in doubt of the equipment's warranty eligibility may call Heartland AG Systems for verification.

Warranty Repairs Made by the Customer

If a Heartland AG Systems dealer determines that the customer is capable, and the customer requests permission to perform select(warranty)repairs on his product, the Heartland AG Systems dealer is authorized to grant this customer request. The servicing dealer should provide the parts to the customer upon request, and to assure that customer is properly instructed on how to perform the repairs correctly.

The servicing dealer is responsible and accountable for claim accuracy and validity; specifically, in areas such as the parts replaced date, and assurances that the parts are installed as instructed by Heartland AG Systems. The comments section of the claim should clearly state that the customer installed the parts. The claim reimbursement will be for parts and applicable handling only. No labor is allowed! All replacement parts must be held for possible recall.

Parts Shortages on Whole-Goods

Dealers may submit a claim for parts shortages discovered during pre-delivery or during final assembly at the dealer's location. All claims for shortages must be submitted 5 days from the original ship date from the plant and before the warranty start date.

Warranty Reimbursement Policies

Heartland AG Systems provides for warranty reimbursement due to defects in material or workmanship only. Warranty does not include restoring any machine or portion thereof, which has accumulated hours of operation, to factory new condition. This includes customer owned and used equipment.

Except for only a few items not available through Heartland AG Systems, all Heartland AG Systems manufactured equipment warranty repairs must be performed using only Heartland AG Systems genuine new or remanufactured parts and accessories. Installation of non-Heartland AG Systems parts does not qualify for warranty reimbursement and can void the machine's warranty.

Parts

It is fully expected that all claims be filed using part numbers from the applicable Heartland AG Systems equipment parts book whenever such part number exists. Heartland AG Systems shall reimburse the dealer at the dealer net price (cost) in effect on the parts replaced date.

Labor

Heartland AG Systems shall reimburse the dealer at 80% of the dealer's posted retail shop labor rate. The retail shop labor rate shall be subject to verification by Heartland AG Systems from copies of actual dealer invoices to customers.

Outside Charges

Specialized repair such as that done by a machine shop will be accepted as part of a warranty claim at actual cost. Explain the parts used and the service work performed in the description section of the claim and retain a copy of the receipt. Retain a copy of the invoice with the shop work order to support the claim. Outside repairs that exceed the cost of the same repair, if performed by the dealer, will be reimbursed at a lower rate.

Freight



Heartland AG Systems will pay the freight charges when a warranty recalled part is to be returned to Heartland AG Systems.

Travel

Travel will only be reimbursed when authorized by a field campaign.

Repairing or Replacing Parts and Components

When performing a warranty repair, a complete part or component should not be replaced under warranty if the repair can be accomplished at a lower cost. If the total cost of the repair including the cost of parts, labor, and/or outside labor or materials is less than 75% of the cost of the parts, the part must be repaired.

Filters and Lubricants

Replacement of lubricants and filters do not qualify for warranty reimbursement unless damage caused by a defect in material or workmanship results in contamination or sudden loss of fluid. Lack of maintenance, operator misuse, or neglect will not qualify for warranty reimbursement.



Heartland Agriculture, LLC



Claim Form Guidelines

Claims Must Have

1. Product identification number (PIN) or serial number. All characters of the PIN must be used on the warranty claim.
 - Claims for parts warranty must use the word "PARTS" for the PIN. An invoice that shows date of sale or date of installation must be supplied for all parts claims.
2. Model Number
3. Date of failure – Claims must be submitted within 30 days or repair.
4. Date of repair
5. Warranty start date. Date the unit warranty starts or date the parts were sold for parts warranty.
6. Description of the problem. Describe all problems pertinent to the claim.
Comments should be as precise as possible, attach a separate sheet if necessary, to describe the problem.
7. Description of the work performed. List each significant action of the repair.
8. Itemize labor. Provide a breakdown of labor for each significant repair action in the "Describe Work Performed" column.
9. Shop order numbers. The shop order number field is used for recording your shop work order number that is related to the claim. The shop order number field can also be used to record the parts invoice number when claiming a parts warranty.
10. Customer information. Customer information includes the customer name, city, state, county, and postal code. It must match the warranty registration.
11. Warranty claim total. The total of all reimbursement costs requested.
12. Dealer signature and date. All claims must be signed and dated by the distributor to be validated.



THIS MESSAGE ALERT SYMBOL INDICATES IMPORTANT SAFETY MESSAGES IN THIS MANUAL. WHEN YOU SEE THIS SYMBOL, CAREFULLY READ THE MESSAGE THAT FOLLOWS AND BE ALERT TO THE POSSIBILITY OF PERSONAL INJURY OR DEATH.

Safety Decals on this machine use the words **Danger, Warning or Caution**, which are defined as follows:

- **DANGER:** Indicates an immediate hazardous situation which, if not avoided, will result in death or serious injury. The color associated with Danger is RED.
- **WARNING:** Indicates a potentially hazardous situation which, if not avoided will result in serious injury. The color associated with Warning is ORANGE.
- **CAUTION:** Indicates a potentially hazardous situation which, if not avoided, may result in minor or moderate injury. It may also be used to alert against unsafe practices. The color associated with Caution is YELLOW.



WARNING

IMPROPER OPERATION OF THIS MACHINE CAN CAUSE INJURY OR DEATH. BEFORE USING THIS MACHINE, MAKE CERTAIN THAT EVERY OPERATOR:

- Is instructed in safe and proper use of the machine.
- Reads and understands the Manual(s) pertaining to the machine.
- Reads and understands ALL Safety Decals on the machine.
- Clears the area of other persons.
- Learns and practices safe use of machine controls in a safe, clear area before operating this machine on a job site.

It is your responsibility to observe pertinent laws and regulations and follow Case Corporation instructions on machine operation and maintenance.

Safety Instructions



The following chapter covers recommended safety instructions, along with other general recommendations and specific machine safety precautions that should be read thoroughly before operating the machine.

Safety

Read and comply with the operators manual and safety instructions before operating the machine.

Understand that your safety and the safety of other persons is measured by how you service and operate this machine. Know the positions and operation of all controls before you try to operate. **Make sure you check all controls in a safe area before starting your work.**

Read this manual completely and all other manuals provided with this vehicle, plus make sure you understand the controls. All equipment has a limit. Make sure you understand the speed, brakes, steering, stability, and load characteristics of this machine before you start to operate.

The safety information given in this manual does not replace safety codes, insurance needs, federal, state, and local laws. Make sure your machine has the correct equipment required by local laws and regulations.

Case Corporation is continuing to work for your safety by making tenders with better protection and by giving these rules for safe operation.



WARNING: THIS SAFETY ALERT SYMBOL INDICATES IMPORTANT SAFETY MESSAGES IN THIS MANUAL. WHEN YOU SEE THIS SYMBOL, CAREFULLY READ THE MESSAGE THAT FOLLOWS AND BE ALERT TO THE POSSIBILITY OF PERSONAL INJURY OR DEATH.

Personal Safety

Throughout this manual and on the machine's safety decals, you will find precautionary statements: **DANGER, WARNING,** or **CAUTION** followed by specific instructions or ISO two panel safety pictorial symbols. These precautions are intended for your personal safety.

Failure to follow the **DANGER, WARNING,** or **CAUTION** instructions may result in serious bodily injury or death.

- **DANGER:** Indicates an immediate hazardous situation that, if not avoided, will

SAFETY INSTRUCTIONS FOR OPERATION

1. DO NOT ALLOW ANYONE TO OPERATE YOUR TYLER TENDER UNTIL HE OR SHE HAS READ THIS MANUAL AND IS COMPLETELY FAMILIAR WITH ALL SAFETY AND OPERATION PROCEDURES.

Decal
12429A



WARNING: Observe the **IMPORTANT SAFETY INSTRUCTIONS** listed below at all times.
THE BEST KIND OF SAFETY IS A CAREFUL OPERATOR.

2. Do not allow the following people to operate or repair this equipment:
 - Children,
 - Irresponsible persons,
 - People under the influence of alcohol, medications or other drugs that can impair judgment or cause drowsiness,
 - Persons unfamiliar with equipment, or
 - People who are careless, unauthorized or unfamiliar with safe operating procedures.
3. Always park unit on flat surface. Shut off engine of vehicle, remove ignition key and set vehicle brakes before making adjustments or repairs to your Tender.
4. Watch for overhead electrical wires or other obstructions before operating.

Decal
11495B

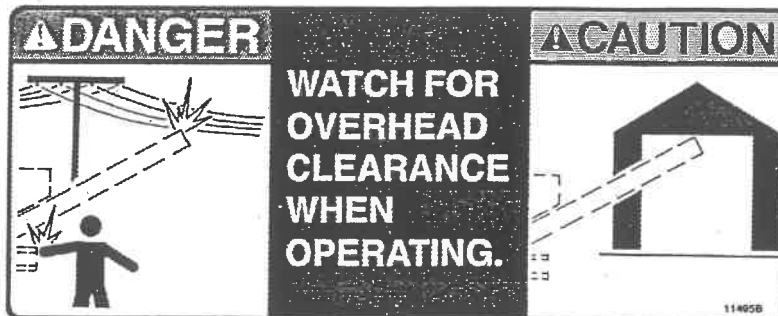

5. Never allow anyone to ride on the Tender.
6. People who are allergic to fertilizer or chemicals must never be allowed in or near the Tender

SAFETY INSTRUCTIONS FOR OPERATION

Continued from page

7. Keep all shields in place.

Decal
12181A



8. Make sure everyone is clear of equipment before starting operation.

Decal
12182A

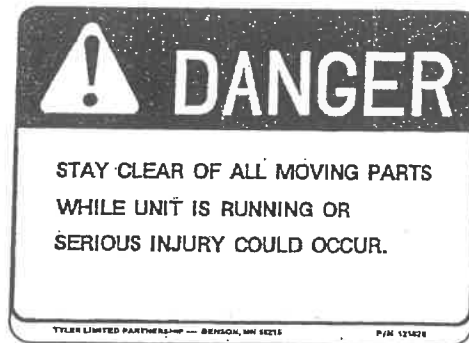

9. Tenders are designed to be mounted on a chassis for over-the-road transportation of granular fertilizer and chemicals. Comply with all local, state, and federal codes and/or laws; including (but not limited to):

- Vehicle weight, height restrictions and bumper, brake and lighting requirements.

10. If any components of the Tender are not functioning properly, do not use the equipment. Remove it from service until it has been properly repaired by a qualified service technician.

11. Do not replace components or parts with other than genuine Factory Service Parts. To do so may reduce the effectiveness of safety features or decrease the accuracy of the unit.



WARNING:

Always wear protective clothing, goggles, respirator and gloves when handling herbicides.



SAFETY INSTRUCTIONS FOR OPERATION



DANGER: Safety instructions furnished by fertilizer manufacturers must be followed exactly to prevent serious harm to individuals and/or the environment.



WARNING: Observe all Federal and state EPA regulations and all local, state and federal codes and/or laws regarding licensing, handling, storage, transportation, application, and waste disposal of fertilizers or other chemicals used.



CAUTION: Fertilizer is very corrosive and will oxidize steel over a period of time. This weakens steel parts and can cause possible safety hazards. Periodically check safety shields and structural members for corrosion. Replace or repair anything that could cause a potential safety hazard.

The following chapter covers recommended safety instructions, along with other general recommendations and specific machine safety precautions that should be read thoroughly before operating the machine.

Safety

Read and comply with the operators manual and safety instructions before operating the machine.

Understand that your safety and the safety of other persons is measured by how you service and operate this machine. Know the positions and operation of all controls before you try to operate. **Make sure you check all controls in a safe area before starting your work.**

Read this manual completely and all other manuals provided with this vehicle, plus make sure you understand the controls. All equipment has a limit. Make sure you understand the speed, brakes, steering, stability, and load characteristics of this machine before you start to operate.

The safety information given in this manual does not replace safety codes, insurance needs, federal, state, and local laws. Make sure your machine has the correct equipment required by local laws and regulations.

Case Corporation is continuing to work for your safety by making tenders with better protection and by giving these rules for safe operation.



WARNING: THIS SAFETY ALERT SYMBOL INDICATES IMPORTANT SAFETY MESSAGES IN THIS MANUAL. WHEN YOU SEE THIS SYMBOL, CAREFULLY READ THE MESSAGE THAT FOLLOWS AND BE ALERT TO THE POSSIBILITY OF PERSONAL INJURY OR DEATH.

Personal Safety

Throughout this manual and on the machine's safety decals, you will find precautionary statements: **DANGER, WARNING, or CAUTION** followed by specific instructions or ISO two panel safety pictorial symbols. These precautions are intended for your personal safety.

Failure to follow the **DANGER, WARNING, or CAUTION** instructions may result in serious bodily injury or death.

- **DANGER:** Indicates an immediate hazardous situation that, if not avoided, will

- ALWAYS put the controls in neutral, shut the engine off, apply the parking brake, and remove the key BEFORE exiting the tow vehicle.
- Extra weight and bad traction conditions, such as mud or ice, increase your stopping distance. Remember, a loaded machine increases the distance needed to stop.
- DO NOT smoke while servicing the machine.
- DO NOT operate the machine while under the influence of alcohol or drugs.
- Hydraulic oil or diesel fuel are high pressured systems. Make sure all lines and fittings are tight and in good condition. These fluids, escaping under pressure, can have sufficient force to penetrate skin and cause serious injury. Failure can result in serious injury or death.
- Escaping hydraulic fluid under pressure can have sufficient force to penetrate skin, causing serious injury. NEVER check for leaks by using any part of your body to feel for escaping fluid.
- Before servicing the machine, make sure the machine has cooled down. Hydraulic components can get hot enough to cause serious injury.
- After servicing the machine ALWAYS replace guards and shields. NEVER operate your machine with guards and shields removed.
- Be aware of all pinch points on the machine and keep clear.
- Keep bolts tight at all times. Always replace worn or broken parts immediately after they are discovered. Do not use the vehicle if any parts are not functioning properly.
- Do not replace parts with other than genuine factory parts. Doing so could decrease the effectiveness of safety features or the accuracy of the machine.
- This machine is designed for the farming industry. Comply with your local and state laws governing weight, lighting, licensing, overhang, bumpers, maximum width, transportation of chemicals, and any other regulations that might apply.

 Safety 

- When disconnecting battery terminals, remove the Negative (-) cable first; then remove the Positive (+). When connecting cables, connect the Positive (+) first, then connect the Negative (-).
- Disconnect the battery (both terminals) before welding on any part of the machine.

Failure to do so may cause damage to sensitive electrical components.

- BATTERY ACID CAUSES SEVERE BURNS. Batteries contain sulfuric acid. Avoid contact with skin, eyes or clothing. Antidote: EXTERNAL - flush with water. INTERNAL - drink large quantities of water or milk. Follow with milk of magnesia, beaten egg or vegetable oil. Call physician immediately. EYES - flush with water for 15 minutes and get prompt medical attention. BATTERIES PRODUCE EXPLOSIVE GASES. Keep sparks, flame and cigarettes away. Ventilate when charging or using in enclosed space. Always shield eyes when working near batteries. KEEP OUT OF REACH OF CHILDREN.
- When working around stage batteries, remember that all of the exposed metal parts are "live". Never lay a metal object across the terminals because a spark, short circuit, explosion or personal injury may result.

Electrical Line Safety

- Know the area before operating the machine. Be aware of power lines, electrical boxes, debris and rocks.
- Watch for adequate overhead clearance when operating the machine.

Machine Operation and Roll-Over Safety

- DO NOT ride or allow other persons to ride on the machine. Riders can fall or can cause an accident.
- DO NOT operate the machine while under the influence of alcohol or drugs.
- Be alert and always know the location of all workers in your area. Keep all other persons completely away from your machine. Injury or death can result if you do not follow these instructions

Noise Level Safety

- Exposure to high noise levels may cause hearing loss. Wearing suitable hearing protective devices protects against loud noise.

Hazardous Chemicals

- If you are exposed to or come in contact with hazardous chemicals you can be

seriously injured. The fluids, lubricants, paints, adhesives, coolants, etc., used with your machine can be hazardous.

- Material Safety Data Sheets (MSDS) provide information about the chemical substances within a product, safe handling procedures, first aid measures and procedures to be taken when the product is accidentally spilled or released. MSDS are available from your chemical dealer. It is the operator's responsibility to be familiar with the safe handling of the chemical used.
- Before you service your machine, check the MSDS for each fluid, lubricant, etc., used in this machine. This information indicates what the risks are and how to service the machine safely. Follow this information when servicing the machine.
- Before you service this machine and before you dispose of the old fluids and lubricants, always remember the environment. DO NOT put oil or fluids into the ground or into containers that can leak.
- Check with your local environmental or recycling center or your dealer for correct disposal information.
- Personal Protective Equipment (PPE) is protective gear worn by pesticide handlers as specified in the use directions on a pesticide label.

Maintenance Safety

- Before you service the machine, place a Do Not Operate tag on the machine.
- Always keep safety and informational decals clean and visible. Replace decals that are damaged, lost, painted over or can not be read.
- When assembling, operating or servicing the machine, wear protective clothing and personal safety devices that are necessary for the particular procedure. Some personal safety devices that may be necessary are protective shoes, face and/or eye protection, hard hat, heavy gloves, filter mask and hearing protection.
- DO NOT wear jewelry or loose fitting clothing that may get caught in moving parts. Always wear close fitting clothing. Keep hands, feet, clothing and hair away from moving parts.
- Never attempt to clear obstructions or objects from the machine while the engine is running.
- Always stop the engine and remove the key from the key switch when leaving the operators seat or the machine.
- When servicing the machine, always have the machine on a firm level surface.

seriously injured. The fluids, lubricants, paints, adhesives, coolants, etc., used with your machine can be hazardous.

- Material Safety Data Sheets (MSDS) provide information about the chemical substances within a product, safe handling procedures, first aid measures and procedures to be taken when the product is accidentally spilled or released. MSDS are available from your chemical dealer. It is the operator's responsibility to be familiar with the safe handling of the chemical used.
- Before you service your machine, check the MSDS for each fluid, lubricant, etc., used in this machine. This information indicates what the risks are and how to service the machine safely. Follow this information when servicing the machine.
- Before you service this machine and before you dispose of the old fluids and lubricants, always remember the environment. DO NOT put oil or fluids into the ground or into containers that can leak.
- Check with your local environmental or recycling center or your dealer for correct disposal information.
- Personal Protective Equipment (PPE) is protective gear worn by pesticide handlers as specified in the use directions on a pesticide label.

Maintenance Safety

- Before you service the machine, place a Do Not Operate tag on the machine.
- Always keep safety and informational decals clean and visible. Replace decals that are damaged, lost, painted over or can not be read.
- When assembling, operating or servicing the machine, wear protective clothing and personal safety devices that are necessary for the particular procedure. Some personal safety devices that may be necessary are protective shoes, face and/or eye protection, hard hat, heavy gloves, filter mask and hearing protection.
- DO NOT wear jewelry or loose fitting clothing that may get caught in moving parts. Always wear close fitting clothing. Keep hands, feet, clothing and hair away from moving parts.
- Never attempt to clear obstructions or objects from the machine while the engine is running.
- Always stop the engine and remove the key from the key switch when leaving the operators seat or the machine.
- When servicing the machine, always have the machine on a firm level surface.

Start Engine



Stop Engine



227L95

Come To Me

Move hands forward and rearward - palms in



Move Away from Me

Move hands forward and rearward - palms out



228L95

Go This Far



All Stop and Hold



229L95

Stop

Move one hand back and forth



Emergency Stop

Move both hands rapidly back and forth



222L95

Turn Machine Left

To stop movement, stop moving hand and make a fist

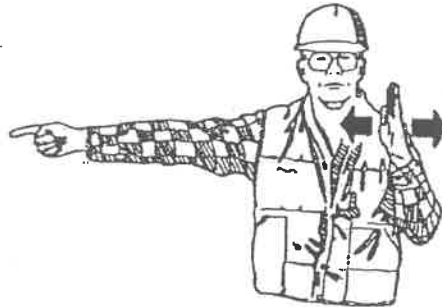

Turn Machine Right

To stop movement, stop moving hand and make a fist



225L95

Safety Decals

Check and replace any worn, torn, hard to read, or missing safety decals on your machine

Safety Decal Pictorials

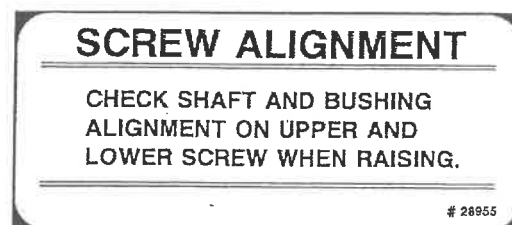
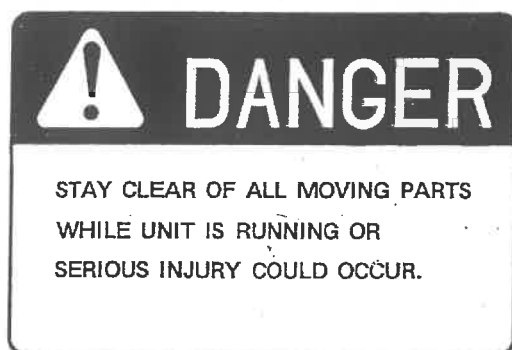
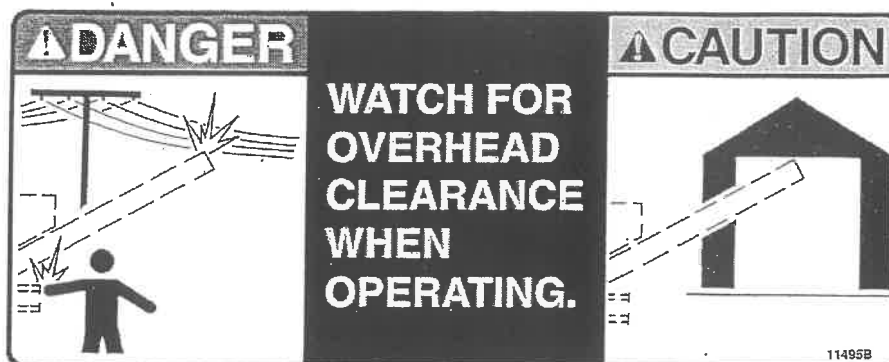
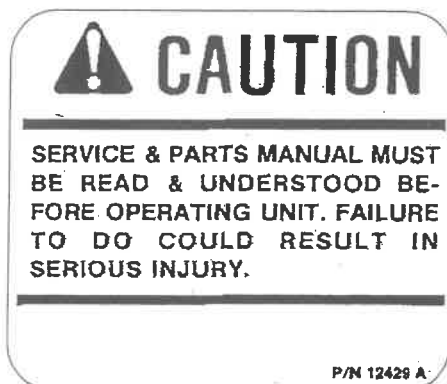

1612 DECAL SHEET

LOCATION OF SERIAL TAG SHOWN ON PAGE 21

12182B



12429A



11495B



28954

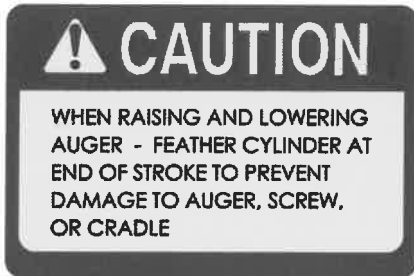

28864



54135



71626



71625



699107L



USA



276534



28223

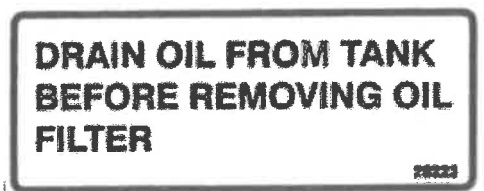

(DECALS ARE NOT TO SCALE)

(decals 276534 and 28223 are included in decal kit but only used on units with an oil tank)

ITEM	PART #	QTY	DESCRIPTION
1	12182B	1	DECAL, DANGER STAY CLEAR OF MOVING PARTS
2	12429A	1	DECAL, CAUTION SERVICE MANUAL MUST
3	11495B	1	DECAL, WATCH OVERHEAD CLEARANCE
4	28954	1	DECAL, CAUTION WHEN RAISING OR LOWERING
5	28864	1	DECAL, DANGER STAY AWAY FROM HINGE AREA
6	54135	3	DECAL, HEARTLAND AG SYSTEMS (LARGE)
7	71626	1	1612 (DRIVER SIDE)
8	699107L	3	DECAL, HEARTLAND AG SYSTEMS (MEDIUM)
9	USA	1	DECAL, MADE IN THE USA
10	71625	1	1612 (DITCH SIDE)

DECALS #6, 7, & 10 ARE POSITIONED SO THAT THEY WILL NOT BE COVERED WHEN A ROLL TARP IS INSTALLED

(PLEASE SEE NOTE ON PAGE 19 REGARDING, PART #'S : 276534 AND 28223)

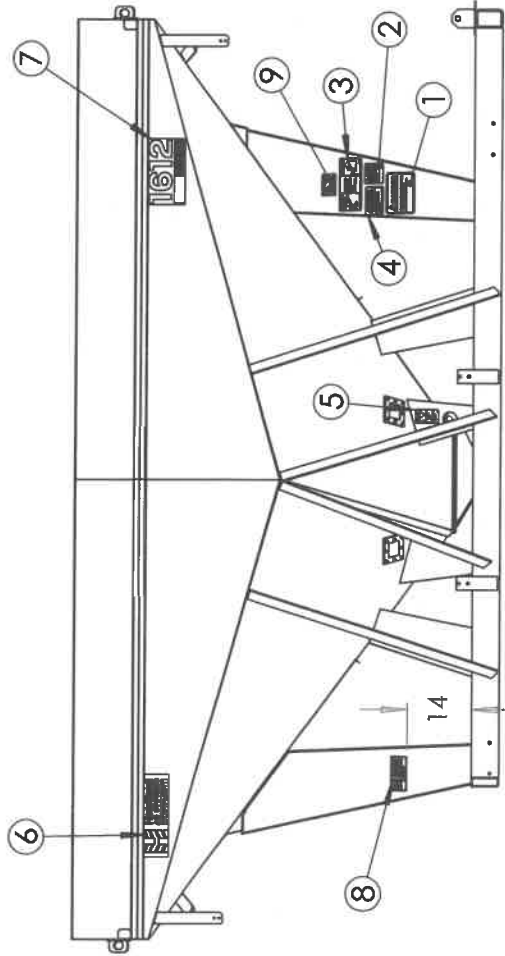

**LH SIDE VIEW
(GATE OPENING CRANK SIDE OF UNIT)**

LOCATE DECALS APPROXIMATELY AS SHOWN

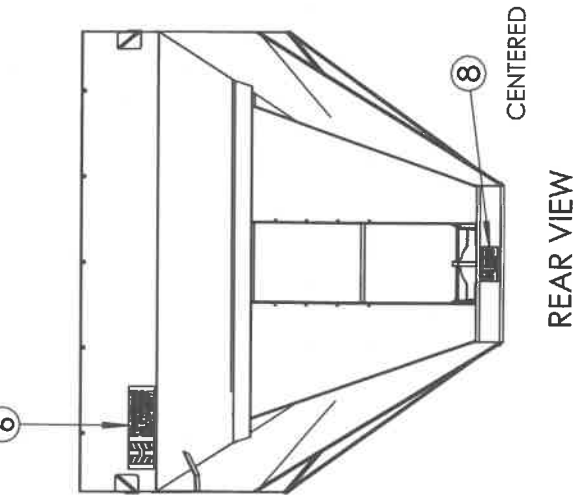

REAR VIEW

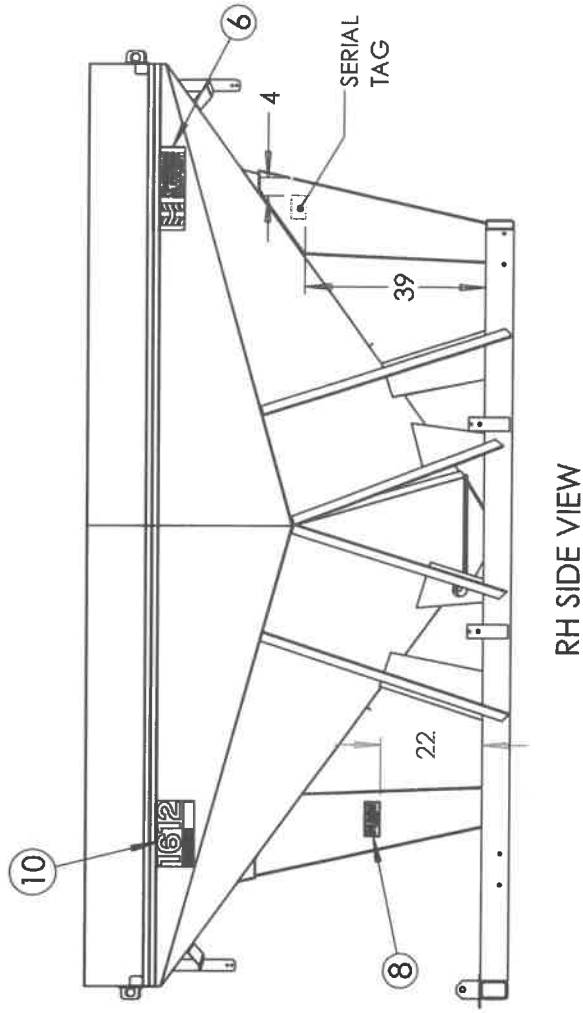

RH SIDE VIEW

1612 TENDER

DECAL LOCATION ON
HYDRAULIC TANK

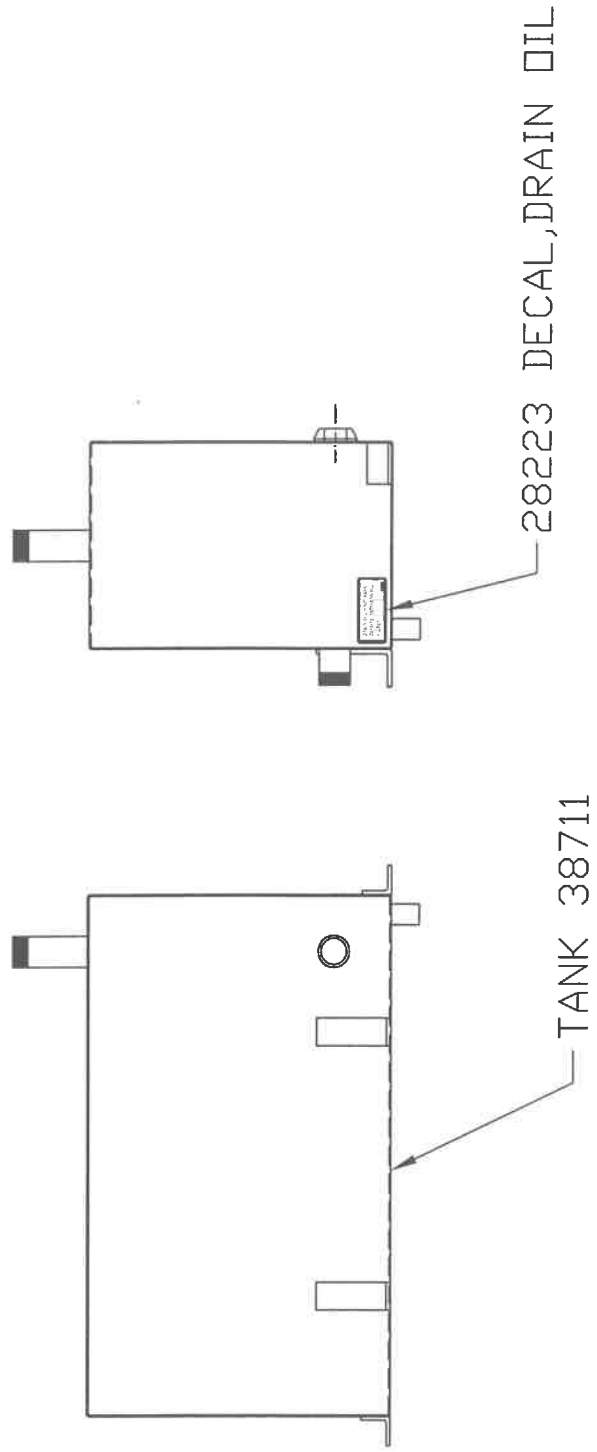
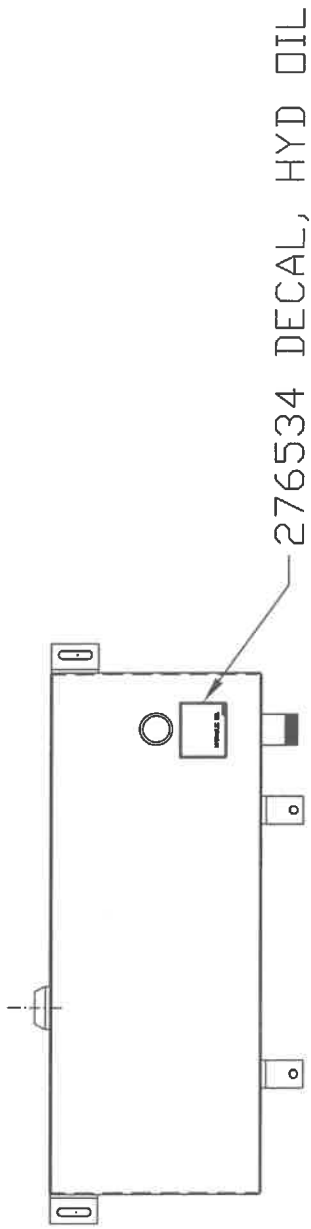

TANK 38711

38711DECAL

22A

Operating Instructions



This chapter starts with a pre-operation checklist. Then it explains certain parts of the machine and how they operate. It also presents detailed instructions for first time operators.

Pre-Operation Checklist



Caution: Read the Safety and Operating Instructions section of this manual before operating the MT16 Series Tender.

Inspect unit:

- Be sure all shipping fasteners are removed.
- Check tender thoroughly for screws, bolts, fittings, etc., which may have come loose during shipping.

Transporting

Before transporting the unit, make sure it is secured to the truck bed, trailer, etc. Be sure that the tarp and auger are properly secured in place. Make sure the auger is in the "down" position before transporting.

Operating the Tender

Truck Hydraulic

At engine speed (1750), the hydraulic pump should be running at a minimum of 22 gallons per minute (gpm). Auger speed on the hydraulic unit is approximately 375 revolutions per minute (rpm).

Engine/Hydraulic

Follow the engine manufacturer's recommendations in the maintenance manual. Check to see the engine has proper oil level before starting.

OPERATING AND SERVICE INSTRUCTIONS

UPON RECEIVING YOUR NEW TENDER

When you receive your new TENDER, be sure that all shipping fasteners are removed prior to operation. Check unit for screws, bolts, fittings and set screws that may have come loose during shipment.

TRANSPORTING THE TENDER

Before transporting the unit, check to make sure it is secured to the truck bed, trailer, etc. Be sure that the tarp and auger are properly secured in place.

OPERATING THE TENDER

TRUCK DIRECT PTO

At engine speed (2000 RPM) auger speed is approximately 400 RPM (Refer to #28217 in manual).

See that the cleanout door is shut and properly secured. Always have the auger running before opening the hopper gate. Always shut the gate and empty the auger before shutting the auger off. Make sure the belts and chain are properly tightened on direct drive units.

TRUCK HYDRAULIC

At engine speed (1750 rpm) the hydraulic pump should be putting out 18 - 20 gpm. (Auger speed on hydraulic unit is approximately 375 rpm.)

ENGINE/HYD. OR ENGINE DIRECT DRIVE

Follow the manufacturer's recommendations in the maintenance manual. Check to see the engine has proper oil level before starting.

UNIT

Make sure auger is in the down position before transporting. See that the cleanout door is shut and properly secured before loading. Always have the auger running before opening the hopper gate. Always shut the gate and empty the auger before shutting the auger off.

Maintenance and Servicing



Daily Machine Maintenance

Overnight Storage

Avoid overnight storage of material in machine if at all possible.

Build-up Of Material

Hosing the machine out with water after each day's use will eliminate build-up if this is done before the material has hardened. The auger may be cleaned by unloading dry gravel or similar abrasive materials. Stainless units should be washed regularly, especially 409 stainless because fertilizers containing chlorides will pit and discolor the metal.



Caution: All residue that is washed off the tender must be disposed of in accordance with local, state, and federal EPA regulations.

Tarp

Loosen the tarp or open Flip top (or Roll tarp) so any excess moisture can escape.

Weekly Machine Maintenance

Greasing

Grease all fittings every 75 hours of operation. Use only one (1) pump of a standard grease gun per application. DO NOT USE AN AIR GUN.



Important: Do not over-grease. Over-greasing will break the seals on the bearings and allow fertilizer and dirt into the bearing; thereby, causing bearing failure.



Between Season Maintenance

Hopper Body

Clean all the old fertilizer out of the unit and wash it down thoroughly. Touch up with a rust preventative paint where needed. Clean and lubricate guides for hopper gates.

Auger

Clean auger by running coarse gravel or some other abrasive material through auger until cleaned. Be sure the clean out door is left open.



Caution: All residue that is washed off the tender must be disposed of in accordance with local, state, and federal EPA regulations.

Unit

- Remove the tarp or open and secure. Flip top (or Roll tarp) to prevent moisture from being trapped inside the hopper.
- If equipped with engine, remove the battery and store inside.
- If stored outside, cover the engine with a cover or tarp of some kind.

Care Of The Roller Chain

To prevent freezing of the roller chain due to rusting, remove and store submerged in fuel oil between seasons. Do not use regular oil for this purpose.

CARE OF MACHINE

DAILY CARE

OVERNIGHT STORAGE:

Avoid overnight storage of material in machine if at all possible.

BUILD-UP OF MATERIAL:

Hosing the machine out with water after each day's use will eliminate build-up if this is done before the material has hardened. Auger may be cleaned by unloading dry gravel or similar abrasive materials. Stainless units should be washed regularly, especially 409 stainless because fertilizers containing chlorides will pit and discolor the metal.



CAUTION: All residue washed off the tender must be disposed of in accordance with local, state, and federal EPA regulations.

TARP:

Loosen the tarp or open Fliptop (or Rolltarp) so any excess moisture can escape.

WEEKLY MAINTENANCE

GREASING:

Grease all fittings every 75 hours of operation. Use only one (1) pump of a standard grease gun per application. DO NOT USE AN AIR GUN.



IMPORTANT: Do not over-grease. Over-greasing will break the seals on the bearings and allow fertilizer and dirt into the bearing; thereby, causing bearing failure.

V-BELT: (Engine direct drive units)

Tension on the drive belts (motor to line shaft) should be measured midway between the sheaves. 1/16" deflection per inch of span (sheave centers). = 19/64 deflection (new belts) at 7# pull on a scale.

CARE OF MACHINE-CARE BETWEEN SEASONS

CARE BETWEEN SEASONS

HOPPER BODY:

Clean all the old fertilizer out of the unit and wash down thoroughly. Touch up with a rust preventative paint where needed. Clean and lubricate guides for hopper gates.

AUGER:

Clean auger by running coarse gravel or some other abrasive material through auger until cleaned. Be sure the clean out door is left open.



CAUTION: All residue washed off the tender must be disposed of in accordance with local, state and federal EPA regulations.

UNIT:

-Remove the tarp or open and secure Fliptop (or Rolltarp) to prevent moisture from being trapped inside the hopper.

-If equipped with engine, remove the battery and store inside.

-If stored outside, cover the engine with a cover or tarp of some kind.

CARE OF THE ROLLER CHAIN:

To prevent freezing of the roller chain due to rusting, remove and store submerged in fuel oil between seasons. Do not use regular oil for this purpose.

LUBRICATION POINTS LISTING

PAGE

Grease fittings on bearing (Ref. No. 8, 10)
Lubricate with oil occasionally (Ref. No. 12)

Grease fittings on bearings & "U" Joints
(Ref. No. 6, 13, 14)

Grease fittings on bearings & "U" Joints
(Ref. No. 2, 3, 6)



NOTE: Use Loctite catalog P/N 592-41 pipe sealant with teflon (TCI P/N 54011) on all hydraulic pipe fittings.

1612SHTAGR

02/08/06

1612 TENDER

SPECIFICATIONS

20 FT. AUGER

DIMENSIONS, BODY
DIMENSIONS, BASE
BODY HEIGHT
SLOPE, FRONT & BACK
SLOPE, SIDES
TARE WEIGHT

100 WIDE X 200 LG.
34 WIDE X 169 LG.
92 INCHES
36 DEGREES FROM
HORIZONTAL
41 DEGREES FROM
HORIZONTAL

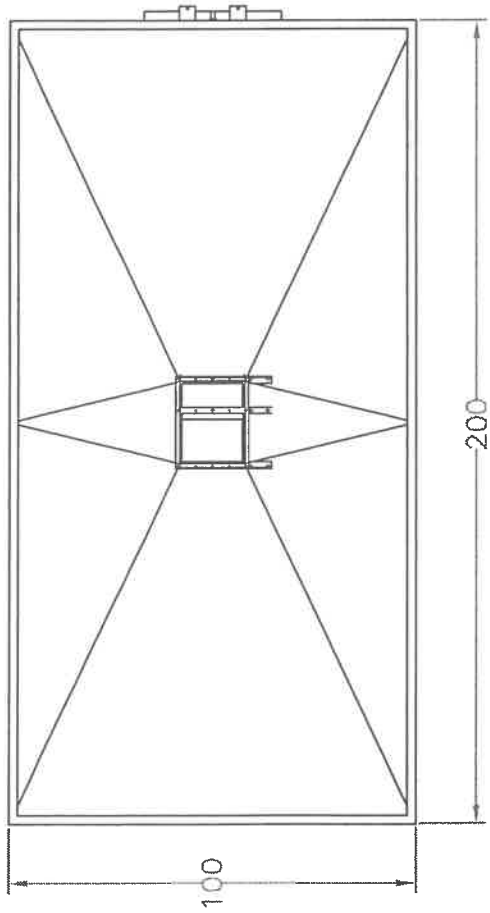

32

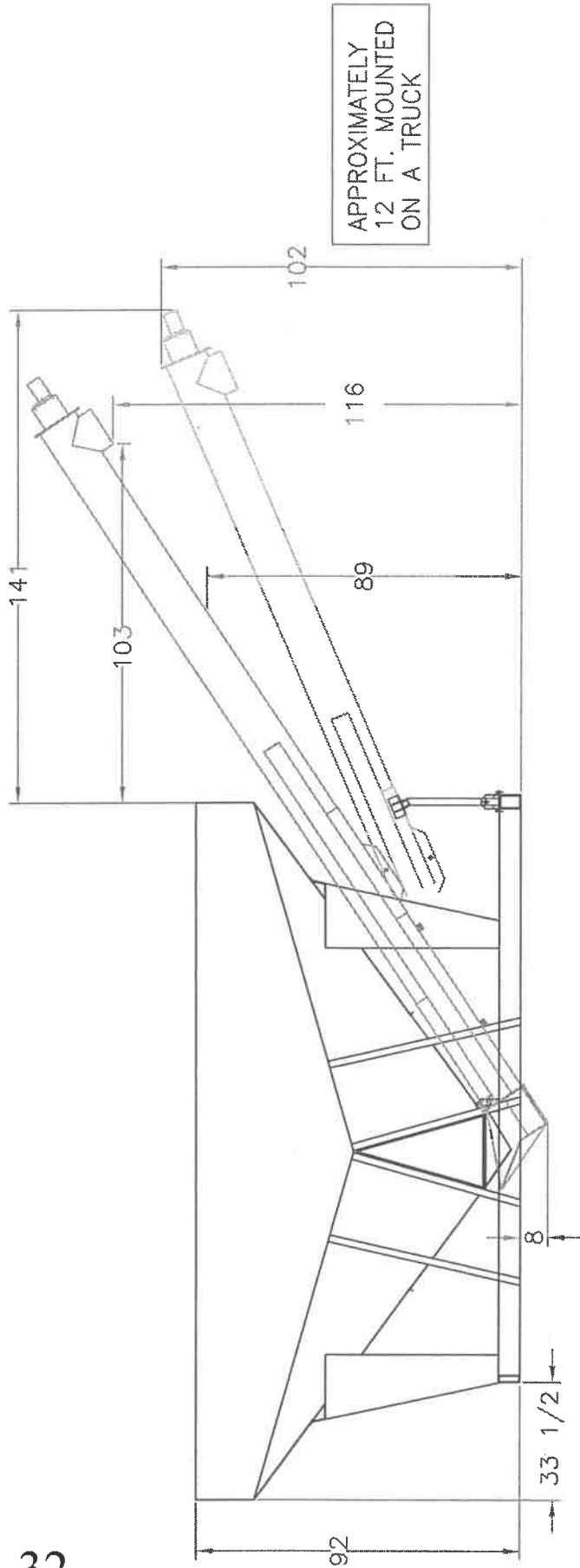

1612EXTAGR

rev 05-05-10

1612 TENDER SPECIFICATIONS

21 1/2 FT. AUGER

DIMENSIONS, BODY

DIMENSIONS, BASE

BODY HEIGHT

SLOPE, FRONT & BACK

SLOPE, SIDES

TARE WEIGHT

100 WIDE X 200 LG.

34 WIDE X 169 LG.

92 INCHES

36 DEGREES FROM

HORIZONTAL

41 DEGREES FROM

HORIZONTAL

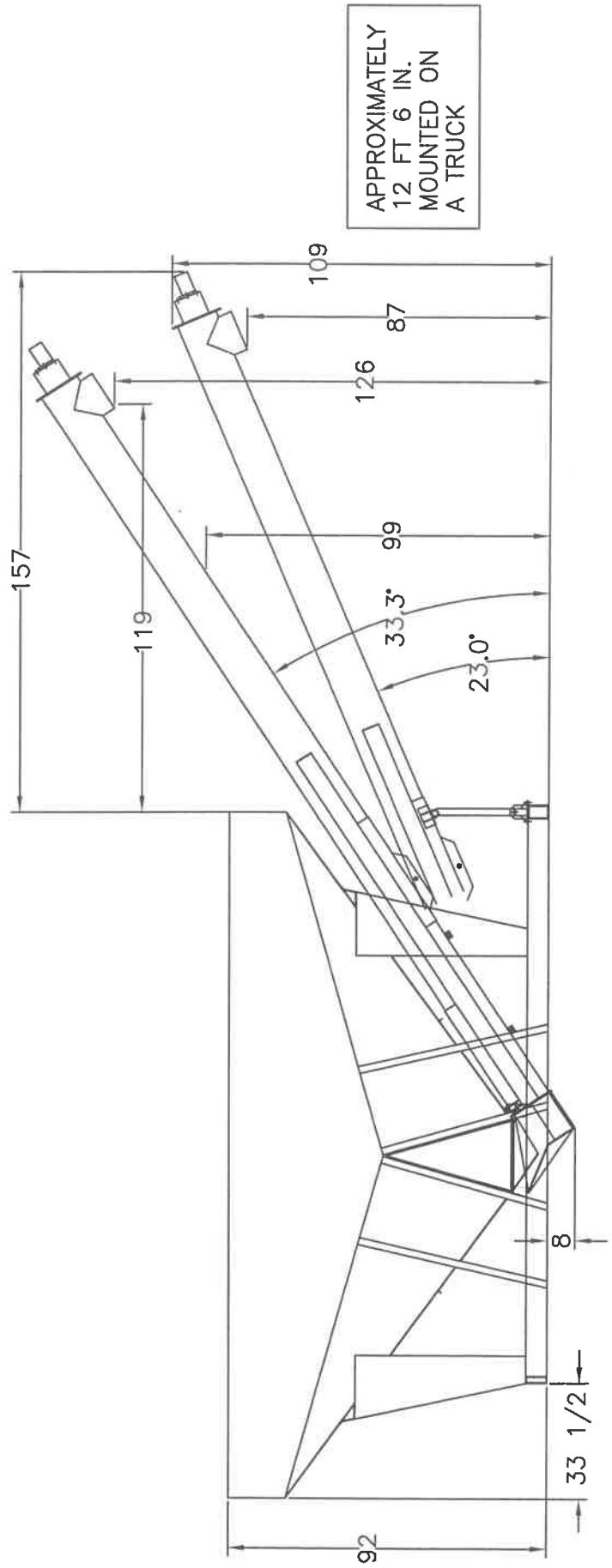
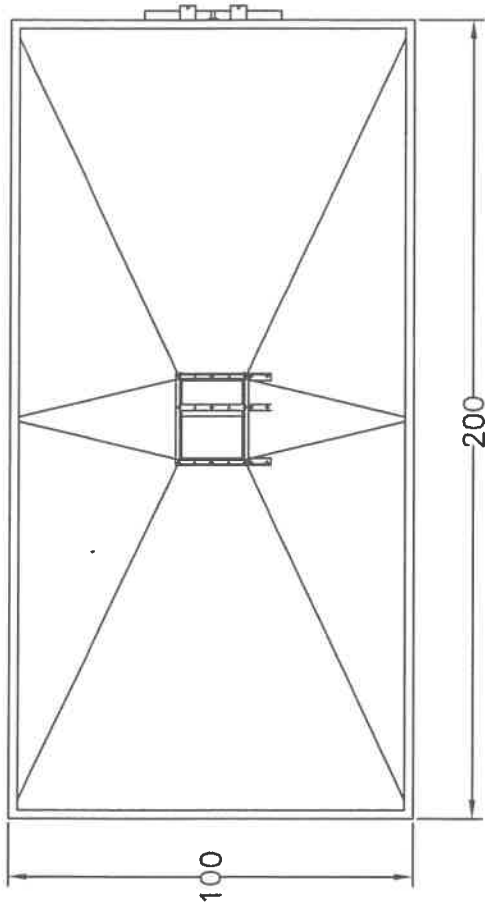

MOUNTING ILLUSTRATION

1612 TRUCK MOUNTED TENDER

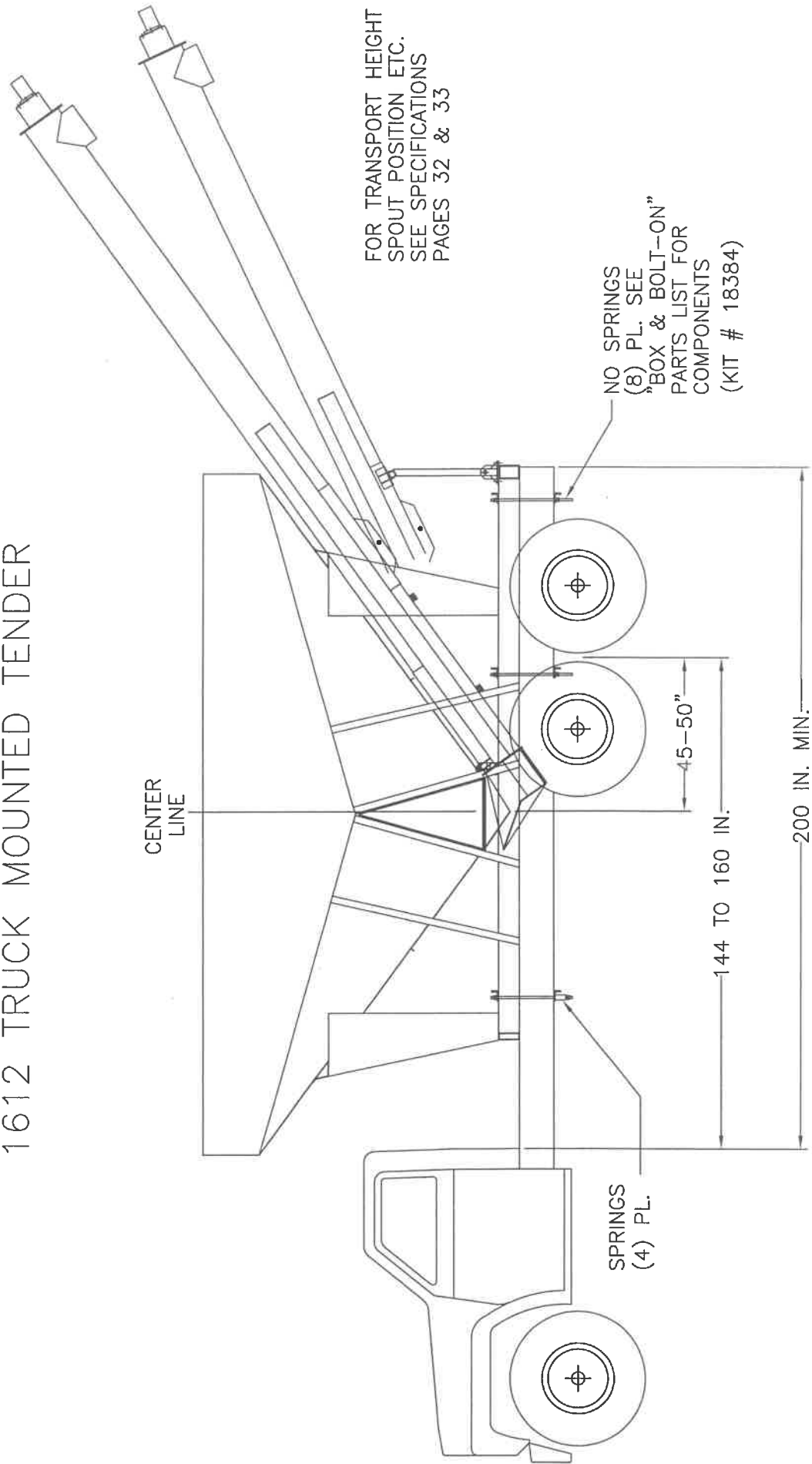

1612TRKMNT
REV 11-01-13

Parts

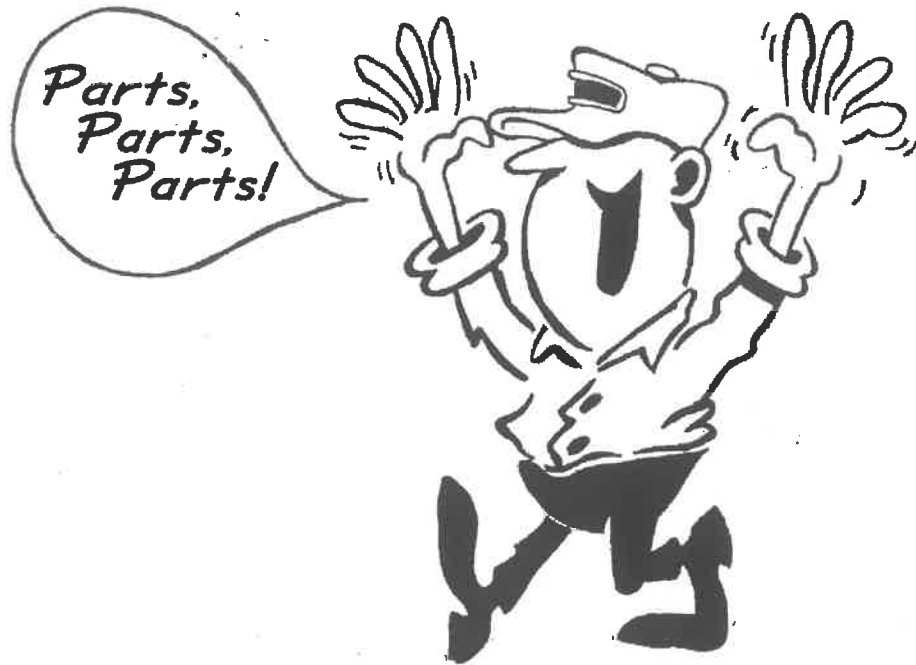

SERIES 1612 TENDER
(STANDARD 2 COMPARTMENT TENDER)
BOX & BOLT ON ITEMS
(FALL 2020 & NEWER)

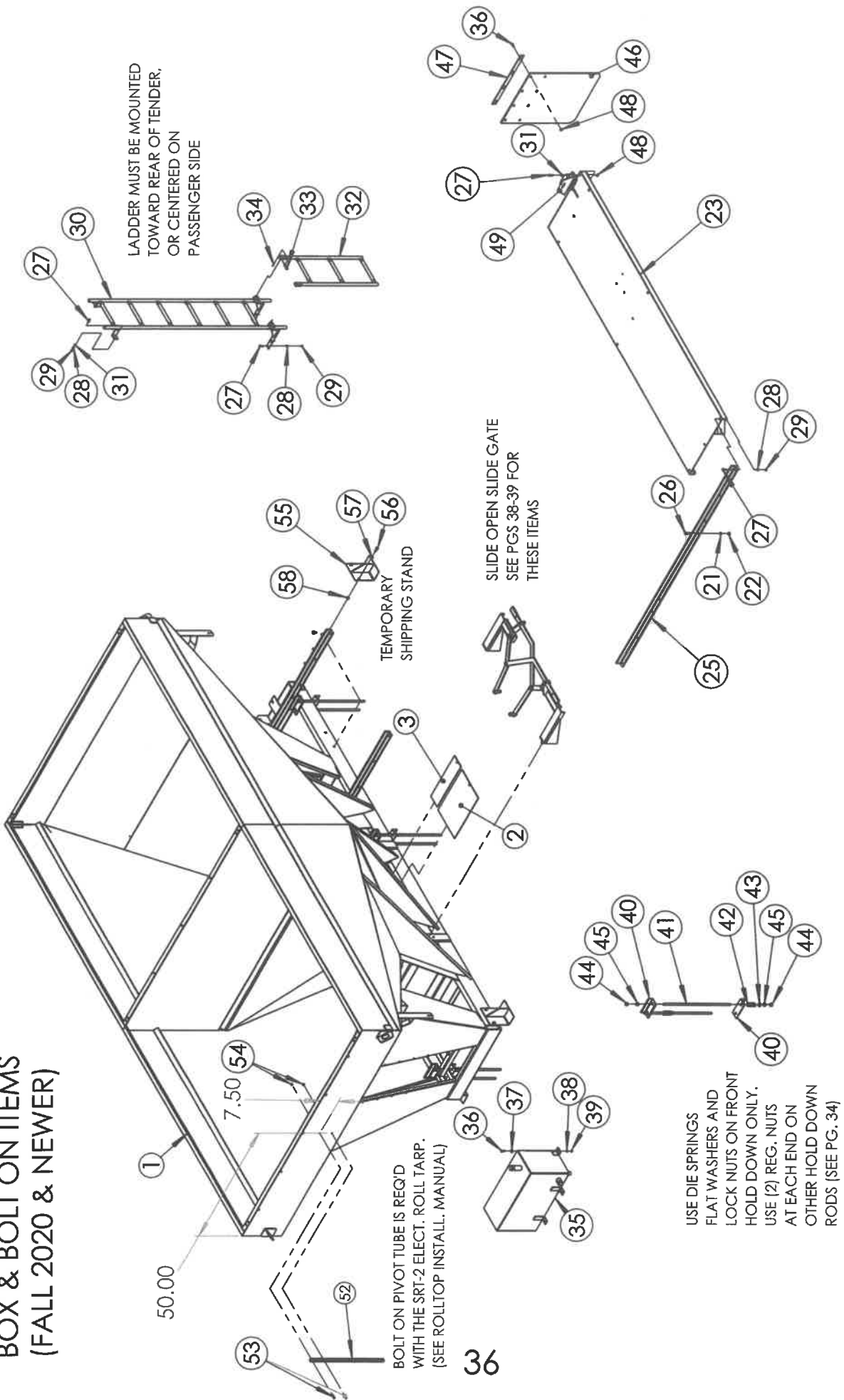

LADDER MUST BE MOUNTED
TOWARD REAR OF TENDER,
OR CENTERED ON
PASSENGER SIDE

BOLT ON PIVOT TUBE IS REQ'D
WITH THE SRT-2 ELECT. ROLL TARP.
(SEE ROLLTOP INSTALL. MANUAL)

SLIDE OPEN SLIDE GATE
SEE PGS 38-39 FOR
THESE ITEMS

USE DIE SPRINGS
FLAT WASHERS AND
LOCK NUTS ON FRONT
HOLD DOWN ONLY.
USE (2) REG. NUTS
AT EACH END ON
OTHER HOLD DOWN
RODS (SEE PG. 34)

SERIES 1612 TENDER

BOX AND BOLT ON ITEMS (FALL 2020 & NEWER)

ITEM NO.	PART NUMBER	DESCRIPTION	QTY.
1	48300119	BODY AND FRAME WELDMENT 409 SS	1
	48300119S	BODY AND FRAME WELDMENT 304 SS	
2	48300065	DISCHARGE GATE, FRONT 409 SS	1
	48300065S	DISCHARGE GATE, FRONT 304 SS	
3	48300138	DISCHARGE GATE REAR 409 SS	1
	48300138S	DISCHARGE GATE REAR 304SS	

SLIDE GATE KIT P/N: 70573A

FOR BLOWN UP SERVICE PARTS FOR SLIDE OPEN SLIDE GATE SEE PGS 38-39 IN THE MANUAL

ITEM NO.	PART NUMBER	DESCRIPTION	QTY.
4	70574	SPACER	2
5	18984800	WASHER NYLON 1/2	18
6	70575	MOUNTING BRACKET RIGHT	1
7	70576	MOUNTING BRACKET LEFT	1
8	18470200	BOLT, HEX 1/4 X 2 NC SS	2
9	70577	DOOR LEVER	1
10	70578	DOOR LEVER RIGHT	1
11	18567400	NUT SS NYLOCK 1/2	6
12	18824800	WASHER FLAT 1/2 SS	16
13	18470175	BOLT SS CAP 1/2 X 1 3/4	2
14	18027436	BOLT SS CAP 1/2 X 2 1/2	2
15	18027438	BOLT, HEX 1/2 X 3 SS	2
16	54143A	HANDLE COVER	2
17	18569200	NUT 1/4 NYLOCK SS	2
18	70579	SLIDE GATE BAR LEFT	1
19	70580	SLIDE GATE BAR RIGHT	1
20	18027417	BOLT HX SS NC 1/2 X 2	4
21 *	18991400	WASHER LOCK 1/2 SS	(4) 10
22 *	18997400	NUT, HEX 1/2-13 NC SS	(4) 10

1612TFP INCLUDES ITEMS 23-26, QTY 18 OF ITEMS 27-29, & QTY 6 OF ITEMS 21 & 22

ITEM NO.	PART NUMBER	DESCRIPTION	QTY.
23	48300224A	FENDER LH	1
24	48300225	FENDER, RH	1
25	48300062	FENDER MOUNT	3
26	18022026	BOLT SS HX 1/2 X 1 1/2	6
27 *	18026824	BOLT HX SS 3/8 X 1 1/4	(18) 28
28 *	18881201	WASHER LOCK 3/8 SS	(18) 24
29 *	18476800	NUT 3/8 SS	(18) 24

1612TLAD INCLUDES ITEMS 30, 32-34, QTY 2 OF ITEM 31, & QTY 6 OF ITEMS 27-29

ITEM NO.	PART NUMBER	DESCRIPTION	QTY.
30	48300234	LADDER	1
31 *	18991200	WASHER FLAT 3/8 SS	(2) 6
32	47007572	LADDER EXTENSION	1
33	18541430	CLEVIS PIN, 1/2 X 2	2
34	18560622	COITER PIN, 1/8 X 1	2

HYDRAULIC OIL TANK (SEE PG. 51) INCLUDES QTY 4 OF ITEM 31

ITEM NO.	PART NUMBER	DESCRIPTION	QTY.
35	38711	OIL TANK 20 GAL	1
36	18056824	BOLT HX ZC 3/8 X 1 1/4	12
37	18811200	WASHER FLAT USS ZC 3/8	4
38	18891200	LOCKWASHER, 3/8 ZC	4
39	18436800	NUT, 3/8 SS	4

18384 BODY MOUNTING KIT COMPLETE

SEE ILLUSTRATION (1612TRKMNT) FOR LOCATION

ITEM NO.	PART NUMBER	DESCRIPTION	QTY.
40	75739	HOLD DOWN ANGLE	12
41	18386	HOLD DOWN ROD	12
42	18387	DIE SPRING	4
43	18851600	WASHER, FLAT 5/8 SAE	4
44	18457900	NUT, LOCK 5/8 NC	8
45	18417900	NUT, 5/8 NC	40

33243 MUD FLAP PACKAGE

INCLUDES ITEMS 46-47, QTY 8 OF ITEM 48, & QTY 8 OF ITEM 27

ITEM NO.	PART NUMBER	DESCRIPTION	QTY.
46	76714	MUD FLAP	2
47	47006302	MOUNTING STRAP	2
48 *	18496800	NUT SER FLG ZC 3/8	(8) 12

1612TLK INCLUDES ITEM 49, AND QTY 4 OF ITEMS 27, 31, & 48, AND STANDARD LIGHT PKG. 28340 (INCLUDES ITEMS 50-51)

ITEM NO.	PART NUMBER	DESCRIPTION	QTY.
49	47007356	LIGHT BRACKET	2
50	01829	TAIL LIGHT-LEFT (W/ LIC. ILL) LED	1
51	01836	TAIL LIGHT - RIGHT (W/O LIS.) LED	1

ITEM NO.	PART NUMBER	DESCRIPTION	QTY.
OPT.	SRT100200	(NOT SHOWN) ELECTRIC ROLL TARP	1
52	47003956	ROLL TARP PIVOT TUBE	1
53	18026826	BOLT CAP SS 3/8 X 1 1/2	2
54	18997900	NUT, 3/8-16 SERRATED FLANGE SS	2

ITEMS 55-58 ARE USED FOR STORAGE AND TRANSPORT ONLY. MAY BE RETURNED FOR CREDIT

ITEM NO.	PART NUMBER	DESCRIPTION	QTY.
55	22197	SHIPPING STAND	4
56	18475240	BOLT HX CAP 1/2-13 X 1 1/4 LG SS	8
57	18851400	WASHER FLAT 1/2 SAE ZC	8
58	18457600	LOCK NUT, 1/2-13NC ZC	8

ITEMS MARKED WITH *, ARE USED IN MULTIPLE LOCATIONS

1612 CATWALK AND SAFETY BAR PARTS ILLUSTRATION

DETAIL A
SCALE 1:15

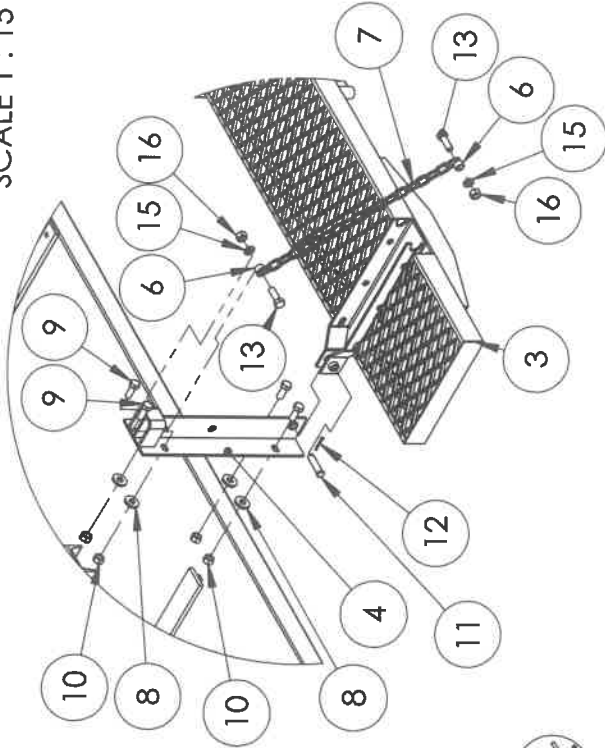

DETAIL B
SCALE 1:15

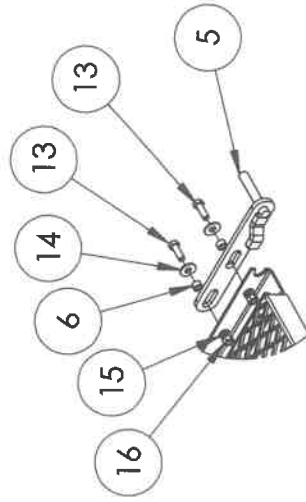

DETAIL C
SCALE 1:15

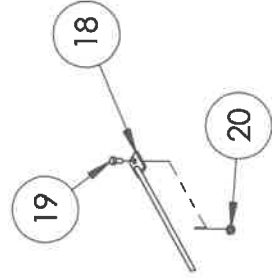

DETAIL D
SCALE 1:15

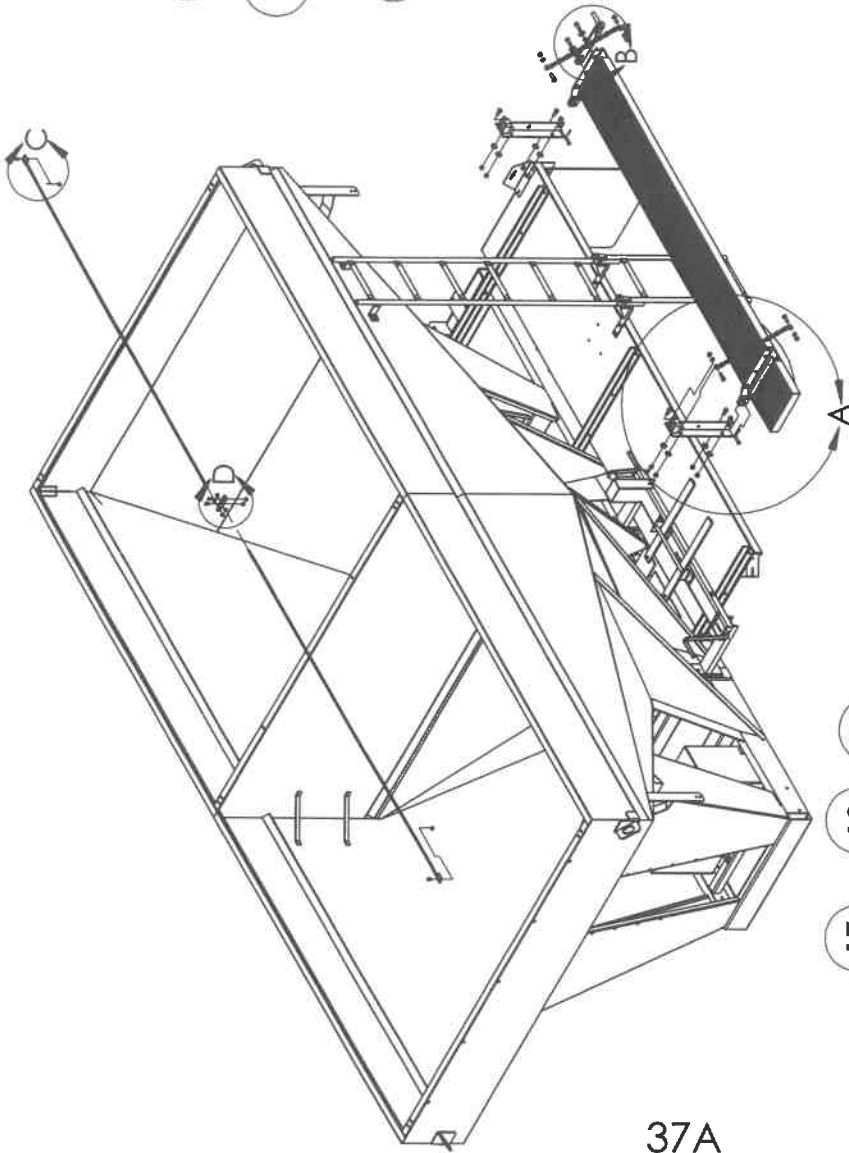
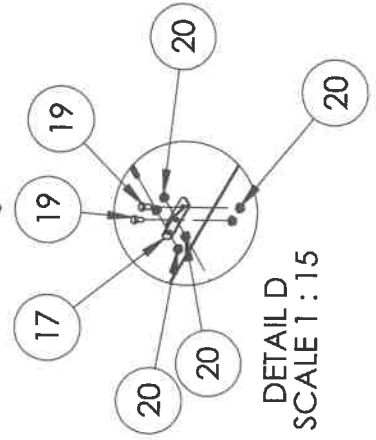

37A

1612 CATWALK AND SAFETY BAR PART LISTING

ITEM NO.	PART NUMBER	DESCRIPTION	QTY.
*1	1612 tender	1612 MOUNTED WITH FENDERS	1
*2	1612TLAD	LADDER PACKAGE (SEE PGS. 36-37)	1
3	47019278	CATWALK EXTENDED	1
4	47019213	END MTG BRACKET	2
5	47019212	TRANSPORT LOCK	1
6	47019202	SPACER BUSHING	6
7	47019211	SUPPORT CHAIN	2
8	47019217	BACKING WASHER	8
9	18475240	BOLT HX CAP 1/2-13 X 1 1/4 LG SS	8
10	18997400	HEX NUT, 1/2-13NC S.S.	8
11	18541430	CLEVIS PIN, 1/2 X 2	2
12	18560722	COTTER PIN, 5/32 X 1	2
13	18057426	BOLT, HX CAP 1/2-13 X 1 1/2 LG	6
14	18811400	WASHER, FLAT 1/2 ZC USS	2
15	18891400	WASHER, 1/2 LOCK ZC	6
16	18417400	NUT, HX 1/2 NC ZC	6
17	47007965	MOUNTING BRACKET	1
18	47003643	MOUNTING BAR	2
19	18026820	BOLT, HX CAP 3/8-16 X 3/4 LG	4
20	18987900	NUT SER FLG SS 3/8	8
21	699125	SAFETY DECAL	1
22	47997965	SAFETY HARNESS AND LANYARD	1

*ITEMS 1 & 2 INCLUDED IN ABOVE TABLE FOR REFERENCE.

CATWALK W/ SAFETY BAR P/N: 16129215 INCLUDES ITEMS #3 THRU 22

SAFETY BAR KIT P/N: 47993643, INCLUDES ITEMS #17 THRU 21

1612 CATWALK MOUNTING INSTRUCTIONS

1. Mount the catwalk on the left hand (driver side) of the tender box.
2. Position (1) end mounting bracket (item 4) so that the edge of the bracket is flush with the lower edge of the stiffener bend, and the outside hole is approximately 51.31 from the edge of the tender box. Using the bracket as a template, mark all 4 holes.
3. Slide the bracket to the second position (143.06") as shown on the diagram, and mark the 4 holes. Front and rear brackets must be level with each other. (see illustration below)
4. Drill ϕ 17/32 holes.
5. Mount the end brackets (item 4) with (4) bolts (item 9), (4) backing washers (item 8), and (4) nuts (item 10) (per bracket). Backing washers go on the inside of the box. Install hardware finger tight at this time.
6. Position the catwalk (item 3) to the front and rear bracket, and mount with (2) clevis pins (item 11) and (2) cotter pins (item 12)
7. Securely fasten all brackets at this time.
8. Assemble a transport lock (item 5) to the outside channel of the catwalk as shown (see Detail B). Position the bushings (item 6) in the slots in the transport lock, and position the hardware so that the head of the bolt (item 13) and the flat washer (item 14) are next to the transport lock and the lock washer (item 15), and the nut (item 16) are next to the channel on the catwalk. Securely tighten the hardware.
9. Assemble the support chains (item 7) to the catwalk and the brackets with the spacers (item 6), bolts (item 13), lock washers (item 15), and nuts (item 16). Test fold and unfold the catwalk to insure proper function.

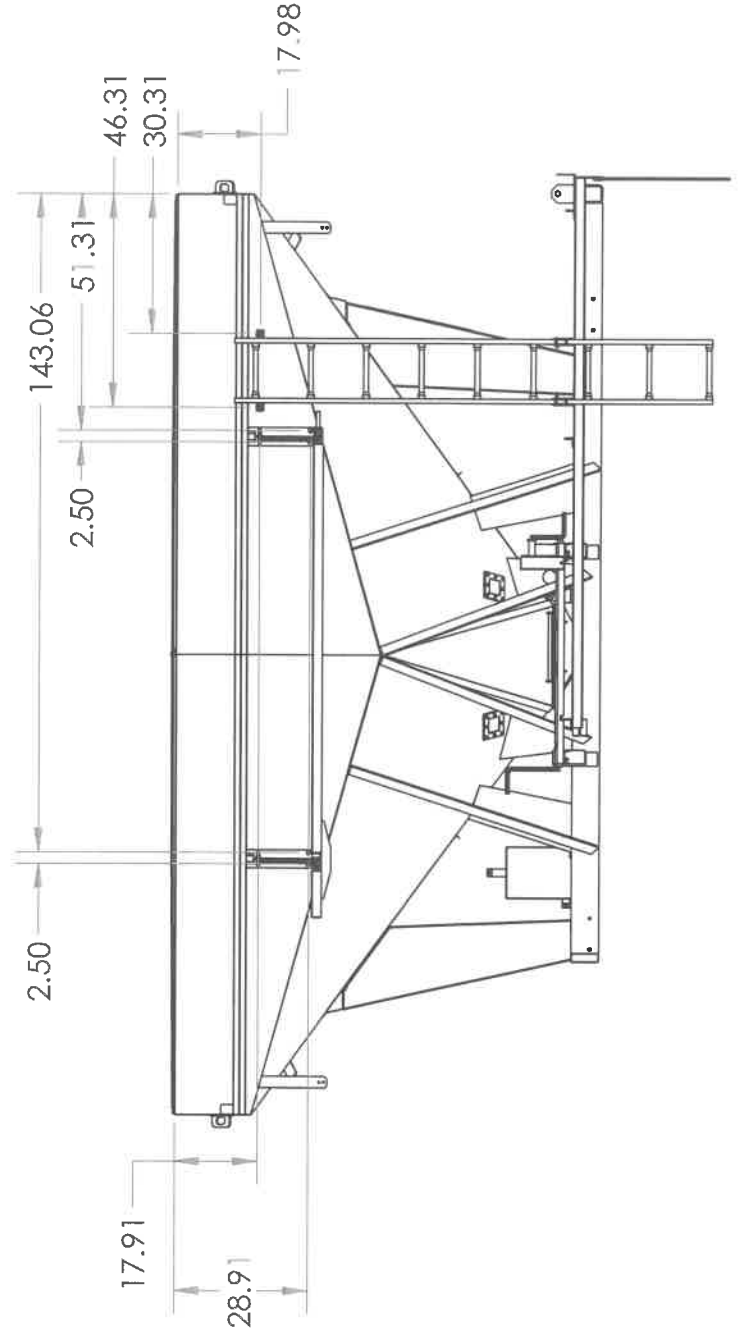

1612 SAFETY BAR MOUNTING INSTRUCTIONS

1. Position the mounting bracket (item 17) on the center rib as shown, mark the holes, remove the bracket, drill the holes, secure bracket with bolts (item 19) and flange nuts (item 20). (Drill bit size 13/32) (If using an Ag Systems Bow Divider the holes exist in the divider but will need to be drilled into the center rib of the tender.)
2. Thread one of the supplied flange nuts (item 20) onto mounting bar (item 18) and place it into the mounting bracket (item 17), (SEE DETAIL E) partially secure with other flange nut (item 20).
3. Mount the end plate of the mounting bar item (18) to the tender using bolt (item 19) and flange nut (item 20).
4. Repeat steps 2-3 for the other side
5. Finish by tightening the flange nuts (item 20) securing the mounting bars (item 18) to the mounting bracket (item 17)

Also required is a Catwalk Safety Harness kit which includes the lanyard and safety harness. (Heartland Ag Systems P/N:47997965) (included)

37D

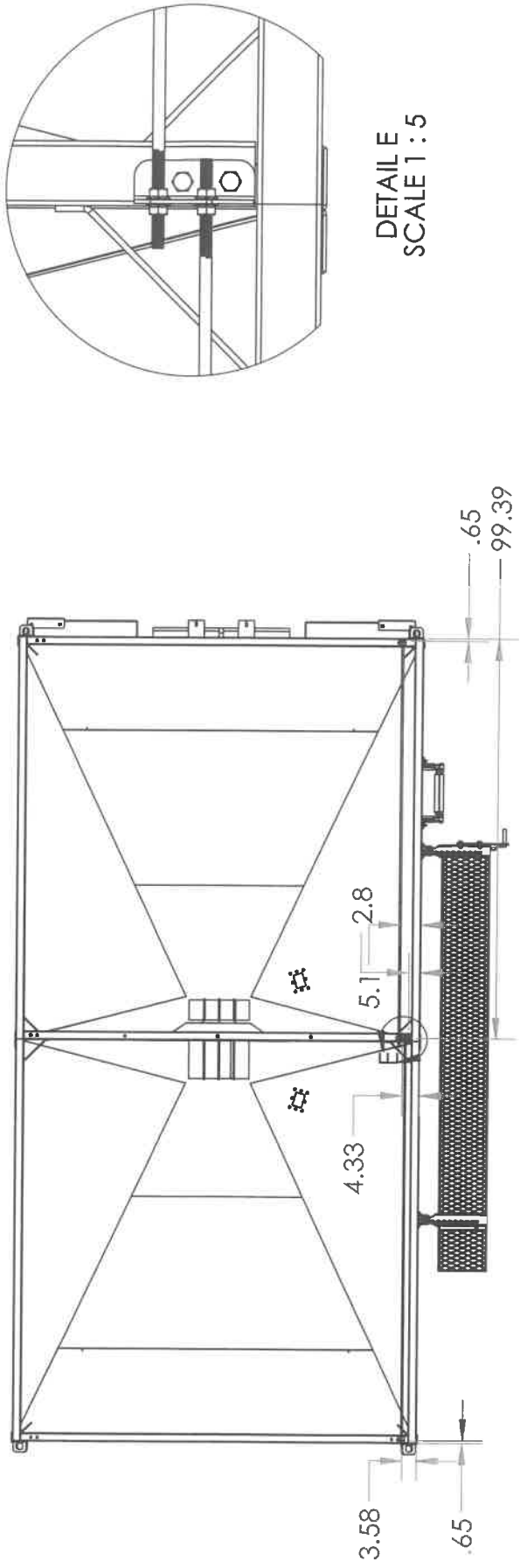

SERIES 1612 TENDER
SLIDE OPEN SLIDE GATE PACKAGE
PART ILLUSTRATION
(FALL 2020 & NEWER)

1612GATESLIDE
02/18/20

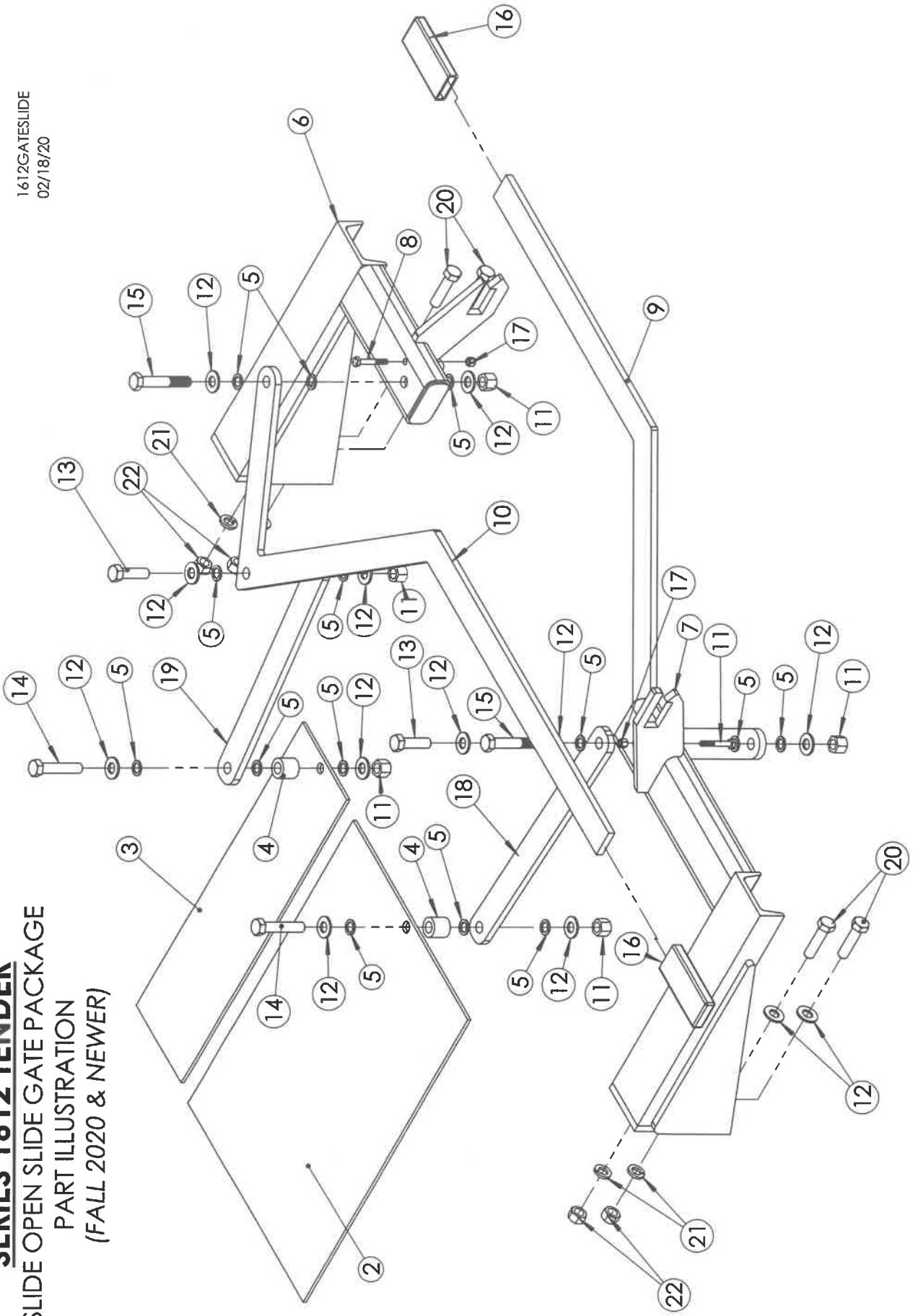

SERIES 1612 TENDER
 SLIDE OPEN SLIDE GATE PACKAGE
 PART LISTING (P/N: 70573A)
 (FALL 2020 & NEWER)

ITEM NO.	PART NUMBER	DESCRIPTION	QTY.
REF. 2	48300065	DISCHARGE GATE, FRONT 409 SS	1
REF. 3	48300138	DISCHARGE GATE REAR 409 SS	1
4	70574	SPACER	2
5	18984800	WASHER NYLON 1/2	18
6	70575	MOUNTING BRACKET RIGHT	1
7	70576	MOUNTING BRACKET LEFT	1
8	18470200	BOLT, HEX 1/4 X 2 NC SS	2
9	70577	DOOR LEVER	1
10	70578	DOOR LEVER RIGHT	1
11	18567400	NUT SS NYLOCK 1/2	6
12	18824800	WASHER FLAT 1/2 SS	16
13	18470175	BOLT SS CAP 1/2 X 1 3/4	2
14	18027436	BOLT SS CAP 1/2 X 2 1/2	2
15	18027438	BOLT, HEX 1/2 X 3 SS	2
16	54143A	HANDLE COVER	2
17	18569200	NUT 1/4 NYLOCK SS	2
18	70579	SLIDE GATE BAR LEFT	1
19	70580	SLIDE GATE BAR RIGHT	1
20	18027417	BOLT HX SS NC 1/2 X 2	4
21	18991400	WASHER LOCK 1/2 SS	10
22	18997400	NUT, HEX 1/2-13 NC SS	10

SERIES 1612 TENDER
(STANDARD 2 COMPARTMENT TENDER)

BOX AND BOLT-ON ITEMS
(FALL 2010 - 2020)

1612BXISO2010+
 01-06-11
 REV 02/19/20

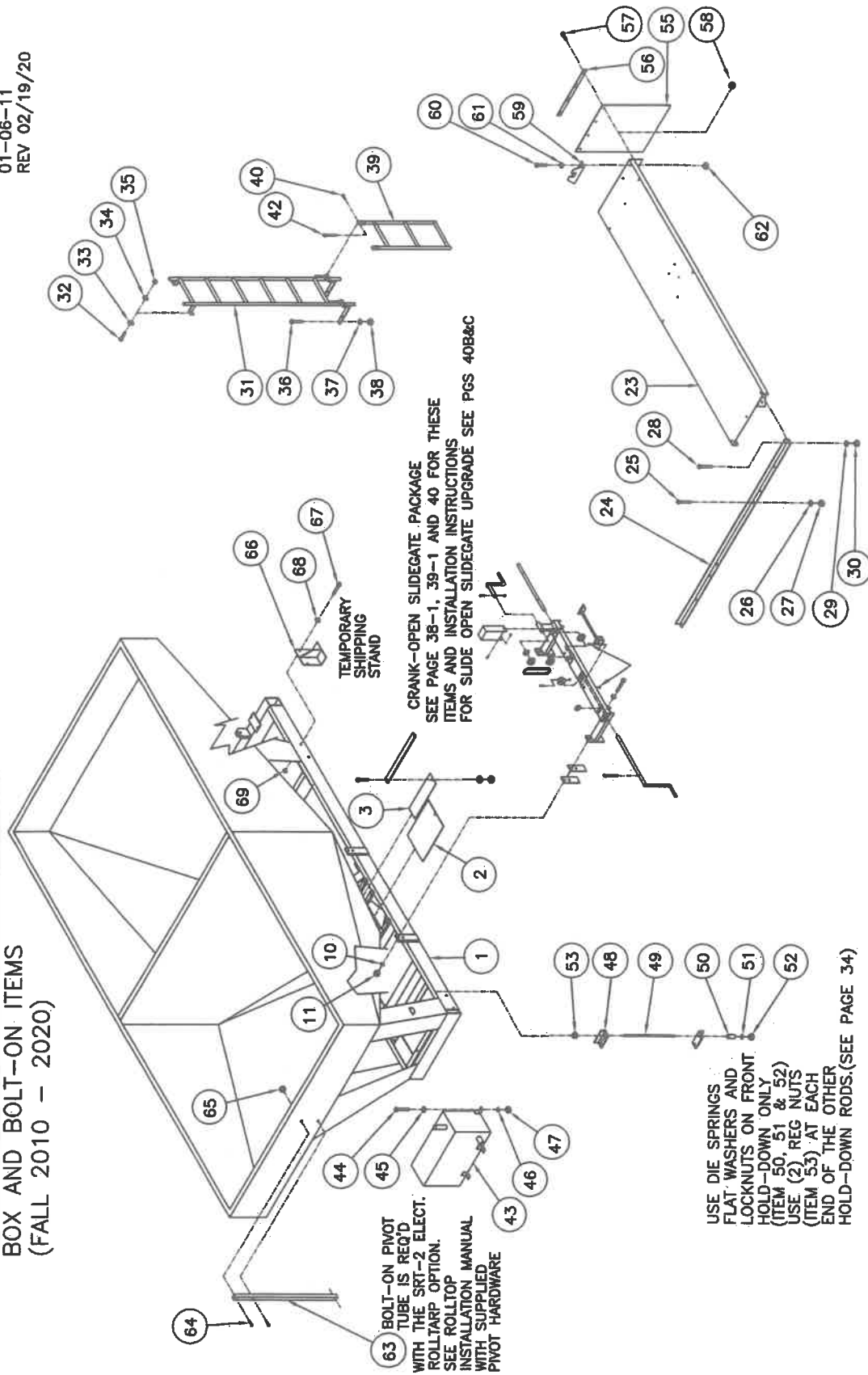

CRANK-OPEN SLIDEGATE PACKAGE
 SEE PAGE 38-1, 39-1 AND 40 FOR THESE
 ITEMS AND INSTALLATION INSTRUCTIONS
 FOR SLIDE OPEN SLIDEGATE UPGRADE SEE PGS 40B&C

63 BOLT-ON PIVOT
 TUBE IS REQ'D
 WITH THE SRT-2 ELECT.
 ROLLTARP OPTION.
 SEE ROLLTOP MANUAL
 WITH SUPPLIED
 PIVOT HARDWARE

65 USE DIE SPRINGS AND
 FLAT WASHERS AND
 LOCKNUTS ON FRONT
 HOLD-DOWN ONLY
 (ITEM 50, 51 & 52)
 USE (2) REG NUTS
 (ITEM 53) AT EACH
 END OF THE OTHER
 HOLD-DOWN RODS.(SEE PAGE 34)

SERIES 1612 TENDER

1612BXLST2010+
09-29-10
REV 02/19/20

BOX AND BOLT-ON ITEMS
(FALL 2010 - SPRING 2020)

ITEM	PART NO.	DESCRIPTION	QTY	ITEM	PART NO.	DESCRIPTION	QTY
1	48300119	BODY AND FRAME WELDMENT 409 SS	1	39	47007572	LADDER EXTENSION	1
2	4830019S	BODY AND FRAME WELDMENT 304 SS	1	40	18541430	CLEVIS PIN, 1/2 X 2	2
3	48300065	DISCHARGE GATE, FRONT 409 SS	1	41	OMITTED		
3A	48300065S	DISCHARGE GATE, FRONT 304 SS	1	42	18560622	COTTER PIN, 1/8 X 1	2
4	48300138	DISCHARGE GATE, REAR 409 SS	1	43	HYD. OIL TANK SEE HYDRAULIC ILLUSTRATION (PAGE 51)		
4A	48300138S	DISCHARGE GATE, REAR 304 SS	1	44	18056824	BOLT, 3/8-16NC, X 1 1/4	4
5	47995532	CRANK-OPEN SLIDEGATE PACKAGE (INCLUDES ITEMS 4 THRU 22)	1	45	18811200	FLAT WASHER, 3/8	4
6				46	18891200	LOCK WASHER, 3/8	4
7				47	18436800	HEX. NUT, 3/8-16NC.	4
8				48	18394	BODY MOUNTING KIT COMPLETE	
8A					SEE ILLUSTRATION NO. (1612TRKMNT) FOR LOCATION		
9				49	75739	HOLD-DOWN ANGLE	12
10				50	18386	HOLD-DOWN ROD	12
10A				51	18851600	DIE SPRING 5/8	4
11				52	18457900	FLAT WASHER	4
12				53	18417900	NUT, CENTER-LOCK, 5/8-11NC.	8
13				54	OMITTED		
14				55	33243	MUD FLAP PACKAGE	2
15				56	76714	MUD FLAP	2
16				57	47006302	MOUNTING STRAP	8
17				58	18056824	BOLT, 3/8-16NC, X 1 1/4	8
18				59	18496800	FLANGE NUT, 3/8-16NC	8
19				60	1612TLK	LIGHT KIT COMPLETE	2
19A				61	47007356	TAIL LIGHT BRACKET	4
19B				62	18026824	BOLT, 3/8-16NC, X 1 1/4	4
20				63	18991200	FLAT WASHER	4
21				64	18991200	FLANGE NUT, 3/8-16NC	4
22				65	18987900	LIGHT KIT COMPLETE	4
23	1612TFP	FENDER PACKAGE INCL. ITEMS 23 TO 30	1	66	22197	SHIPPING STAND	4
24	48300224A	FENDER, L.H. 1/2	1	67	18027438	BOLT, 1/2-13NC, X 1 1/4	8
25	48300225	FENDER, R.H.	1	68	18851400	FLAT WASHER, 1/2	8
26	48300062	FENDER MOUNT	3	69	18457600	LOCK NUT, 1/2-13NC.	8
27	18022026	BOLT, 1/2-13NC, X 1 1/2	6				
28	18991400	LOCK WASHER	6				
29	18997400	HEX. NUT, 1/2-13NC.	6				
30	18026824	BOLT, 3/8-16NC, X 1 1/4	18				
31	18991200	LOCK WASHER, 3/8	18				
32	18476800	HEX. NUT, 3/8-16NC.	18				
33	1612TLAD	LADDER PACKAGE (ITEMS 31 THRU 42)	1				
34	48300234	LADDER, SIDE MOUNT	2				
35	18026824	BOLT, 3/8-16NC, X 1 1/4	2				
36	18991200	FLAT WASHER, 3/8	2				
37	18881201	LOCK WASHER, 3/8	2				
38	18476800	HEX. NUT, 3/8-16NC.	2				
39	18881201	LOCK WASHER, 3/8	2				
40	18026824	BOLT, 3/8-16NC, X 1 1/4	4				
41	18881201	LOCK WASHER, 3/8	4				
42	18476800	HEX. NUT, 3/8-16NC.	4				
43	18881201	LOCK WASHER, 3/8	4				
44	18476800	HEX. NUT, 3/8-16NC.	4				

FOR SERVICE PARTS
ON THE 2010 & 2020
CRANK-OPEN
SLIDEGATE PACKAGE
SEE PAGES 38-1 & 39-1
OF THIS MANUAL

SERIES 1612 TENDER

**BOX AND BOLT-ON ITEMS
CRANK-OPEN SLIDEGATE PACKAGE
COMPLETE PKG # 47995532**

STANDARD ON 1612
(FALL 2010 - 2020)

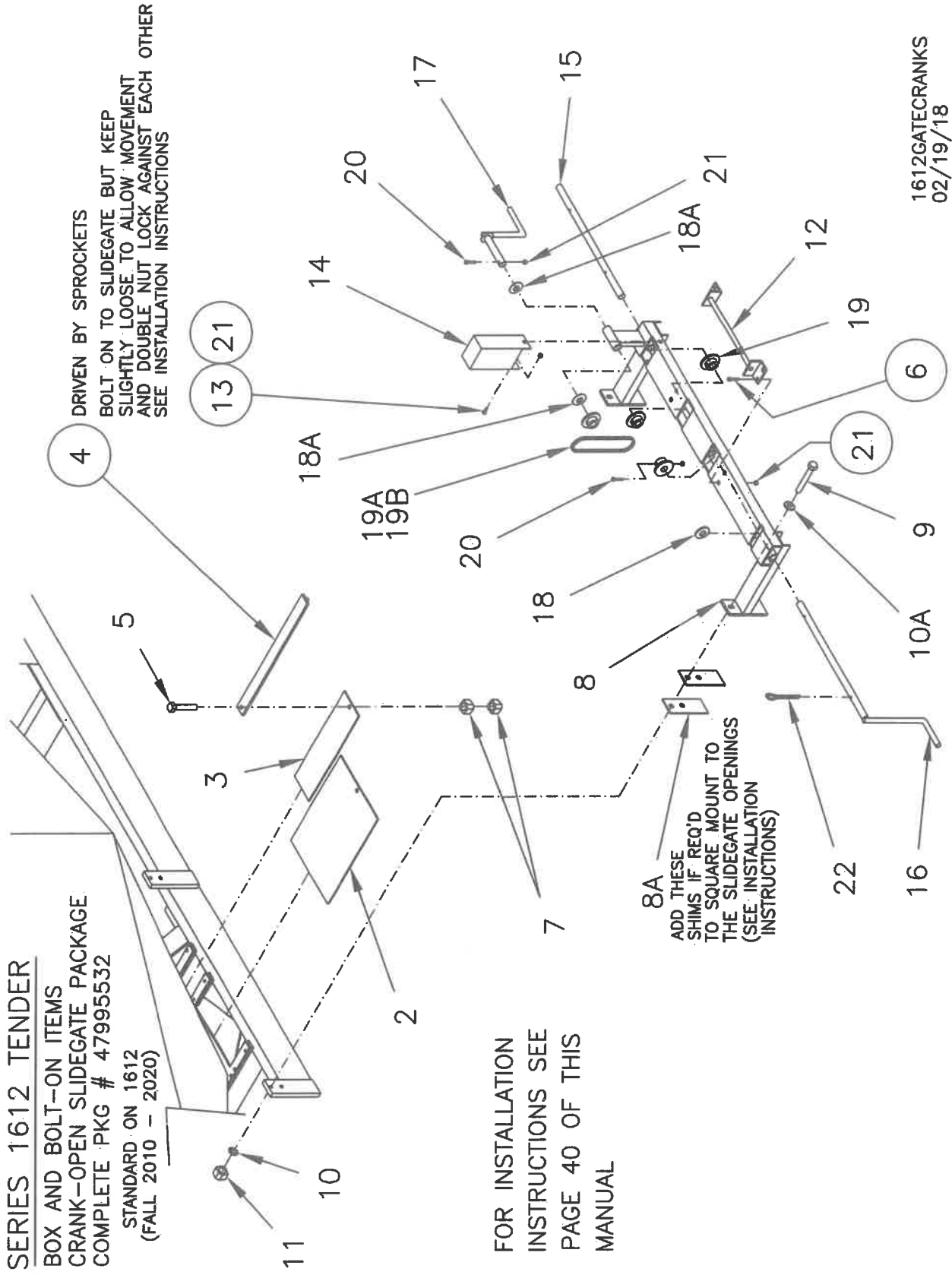

FOR INSTALLATION
INSTRUCTIONS SEE
PAGE 40 OF THIS
MANUAL

1612GATECRANKS
02/19/18

SERIES 1612 TENDER

1612GATECRANKLST
02/19/20

CRANK-OPEN SLIDEGATE PACKAGE (FALL 2010 - 2020)

<u>ITEM</u>	<u>PART NO.</u>	<u>DESCRIPTION</u>	<u>QTY</u>
3A	47995532	CRANK-OPEN SLIDEGATE PACKAGE (INCLUDES ITEMS 4 THRU 22)	1
4	47005543	SLIDEGATE BAR WELDMNT	2
5	18027417	BOLT, 1/2-13NC. X 2	2 S.S.
6	18026424	BOLT, 5/16-18 NC. X 1 1/4	4 S.S.
7	18997400	HEX. NUT, 1/2-13NC.	4 S.S.
8	47005532	CRANK MOUNT WELDMNT (CHAIN DRV)	1
8A	47005531	CRANK MOUNT SHIM PLATE	4
9	18027417	BOLT, 1/2-13NC. X 2	4 S.S.
10	18991400	LOCK WASHER, 1/2	4 S.S.
10A	18824800	FLATWASHER, 1/2	2 S.S.
11	18997400	HEX. NUT, 1/2-13NC	4 S.S.
12	47005542	GUIDE BAR WELDMNT (FOR CHAIN DRV)	1
13	18026418	BOLT, 5/16-18 NC. X 3/4	2 S.S.
14	47005557	CHAIN GUARD WELDMNT	1
15	47005536	SHAFT LOWER RH	2 S.S.
16	48300209	GATE CRANK, FRONT	1
17	47005533	GATE CRANK, RH	1
18	18862200	FLAT WASHER, 1" SAE	1 S.S.
18A	18300321	WASHER N.R. MACH 14 GA X 1 ZP	2
19	48300198	SPROCKET, #40x15T,(1" BORE)	4
19A	300191	CHAIN, #40 SS X 19 7/8" LONG	1
19B	31028	CONNECTING LINK, #40 SS	1
20	18026426	BOLT, 5/16-18NC. X 2	4 S.S.
21	18476351	LOCK-NUT, 5/16-18NC.	10 S.S.
22	18570826	COTTER PIN, 3/16 X 1 1/2	1 S.S.

SERIES 1612 TENDER
 2010 CRANK-OPEN SLIDEGATE PACKAGE
 RETROFIT INSTALLATION INSTRUCTIONS

1612GATEINSTALL
 11-11-10

- STEP 1: UNBOLT THE EXISTING CRANK MOUNT WELDMENT FROM THE FRAME AND REMOVE IT.
 STEP 2: UNBOLT AND REMOVE THE EXISTING GATE ARMS FROM THE SLIDEGATES.
- STEP 3: PLACE ITEM 8 (CRANK MT) UPSIDE DOWN AS NEEDED TO PROVIDE ACCESS TO NUTS ETC. INSTALL ITEM 12 GUIDE BAR USING ITEMS 6 AND 21, BUT DO NOT TIGHTEN AT THIS TIME. THREAD NUT ONTO APPROX 1/4" OF BOLT AND LEAVE ALL 4 BOLTS LOOSE. IMPORTANT: THESE WILL NEED TO BE TIGHTEND IN STEP 11 OF THE ASSEMBLY PROCESS.
- STEP 4: SLIDE ITEM 16 (FRONT CRANK) INTO THE BUSHING ON ITEM 8 AS SHOWN AND SLIDE ON ITEM 18 INTO THE SLOT AS SHOWN THEN SLIDE ON THE DRIVE SPROCKET INTO THE SLOT AS SHOWN AND BE SURE THE SPROCKET IS FACING THE PROPER DIRECTION PER DIAGRAM BEFORE SECURING IT TO THE SHAFT WITH ITEMS 20 & 21, AND INSTALL ITEM 22 TO HOLD ITEM 18 IN PLACE ON THE SHAFT.
- STEP 5: SLIDE ITEM 15 (SHAFT) INTO THE BUSHING ON ITEM 8 AS SHOWN AND SLIDE ON ITEM 18 AS SHOWN THEN SLIDE ON 2 DRIVE SPROCKETS IN THE SLOTS POSITIONED FACING AS SHOWN AND BE SURE THE SPROCKETS ARE FACING THE PROPER DIRECTION PER DIAGRAM BEFORE SECURING THEM TO THE SHAFT WITH ITEMS 20 & 21. THE SHAFT SHOULD SPIN FREELY AND THE DRIVE SPROCKETS BE PARTIALLY EXPOSED ABOVE THE SLOTS WHEN PROPERLY INSTALLED.
- STEP 6: SLIDE ITEM 17 (RH CRANK) INTO THE BUSHING ON ITEM 8 AS SHOWN AND SLIDE ON ITEM 18 AS SHOWN THEN SLIDE ON A DRIVE SPROCKET AS SHOWN AND SECURE WITH ITEMS 20 & 21. BE SURE THE SPROCKET IS FACING THE PROPER DIRECTION PER DIAGRAM BEFORE SECURING IT TO THE SHAFT WITH ITEMS 20 & 21. THE UPPER AND LOWER SPROCKETS MUST BE IN ALIGNMENT.
- STEP 7: WRAP DRIVE CHAIN (ITEM 19A) AROUND THE 2 DRIVE SPROCKETS AND CONNECT THE CHAIN TOGETHER USING THE CONNECTING LINK ITEM 19B. CRANK ITEM 17 TO SEE THAT THE CHAIN DRIVES THE LOWER SHAFT SMOOTHLY.
- STEP 8: POSITION THE CHAIN GUARD (ITEM 14) OVER THE SPROCKETS AS SHOWN AND BOLT IT TO ITEM 8 AS SHOWN USING ITEMS 13 AND 21.
- STEP 9: THE NEXT STEP WILL TO BOLT THE ENTIRE ASSEMBLY TO THE BASEFRAME MOUNTING PLATES. AS SHOWN USING ITEMS 9, 10, 10A, 11. TO FUNCTION PROPERLY THE GATECRANK ASSEMBLY ITEM 8 MUST BE AS SQUARED AS MUCH AS POSSIBLE TO THE HOPPER SLIDEGATE OPENINGS ON THE BODY. SHIM PLATES (ITEM 8A) IF REQUIRED MAY NEED TO BE USED TO SQUARE THE ITEM 8 TO THE BODY. VERTICAL ADJUSTMENTS CAN BE MADE USING THE SLOTS IN THE MOUNTING PLATES ON ITEM 8.
- STEP 10: POSITION THE SLIDEGATE BARS (ITEM 4) ONTO THE SPROCKETS AND BOLT THEM TO THE SLIDEGATES AS SHOWN USING ITEMS 5, AND 7, BUT DOUBLE NUT AS SHOWN TO KEEP THE SLIDEGATE BARS SOMEWHAT LOOSE, TO ALLOW SOME SELF-ALIGNMENT MOVEMENT AS THE GATES ARE CRANKED IN AND OUT. DO NOT TIGHTEN THE SLIDEGATE BARS TIGHTLY DOWN TO THE SLIDEGATES, ALLOW GAP AS SHOWN.
- STEP 11: ORIENT THE CRANKS SO THE CRANK HANDLE WILL BE PAST CENTER WHEN CLOSED (10 O'CLOCK POSITION) AS SHOWN IN DETAIL A THEN TIGHTEN DOWN THE GUIDE BAR (ITEM 12) TO ITEM 8 TO KEEP THE SPROCKETS MAKING GOOD DRIVE CONTACT WITH THE CHAIN ON THE UNDERSIDE OF THE SLIDEGATE BARS.
- STEP 12: RUN THE CRANKS TO FULLY OPEN AND CLOSE THE SLIDEGATES, THEN MAKE ANY MINOR ADJUSTMENTS. THE GATE WILL OPERATE PROPERLY IF THE SLIDEGATES RUN CENTERED IN THE GATE TRACK OPENINGS AND THE SLIDEGATE BARS (ITEM 4) RUN AS LEVEL AS POSSIBLE DURING OPERATION.
- STEP 13: CHECK TO SEE THAT WHEN THE SLIDEGATES ARE CLOSED THE CRANK HANDLES ARE IN THE 10 O'CLOCK POSITION SO THE GATES DON'T VIBRATE OPEN DURING TRANSPORTATION. LOOSEN ITEM 12 TO MAKE ANY CRANK POSITION ADJUSTMENTS NEEDED, THEN RETIGHTEN.

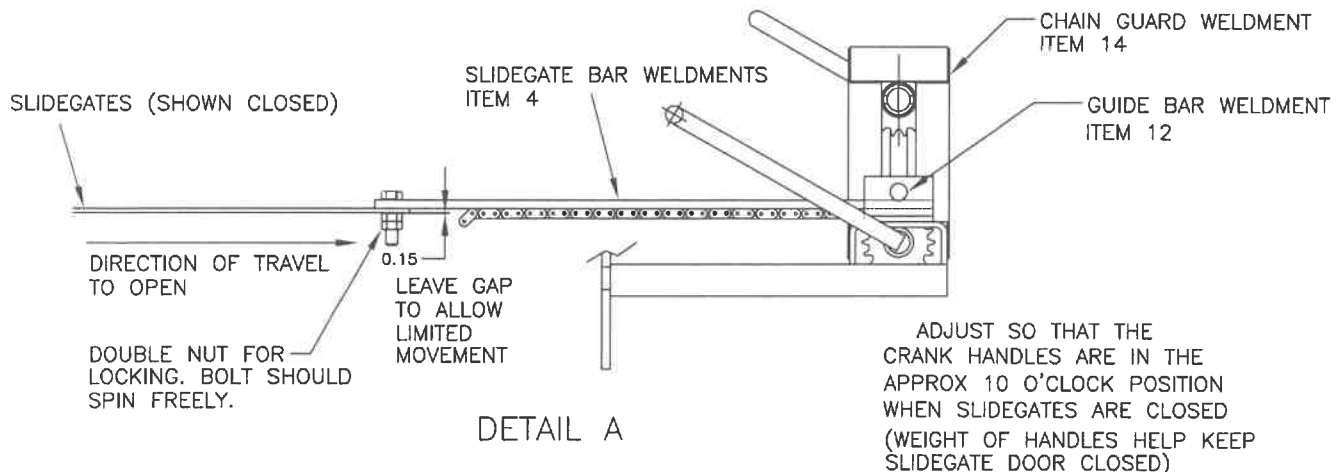

40A

1612 TENDER SLIDE GATE UPGRADE (PART ILLUSTRATION)

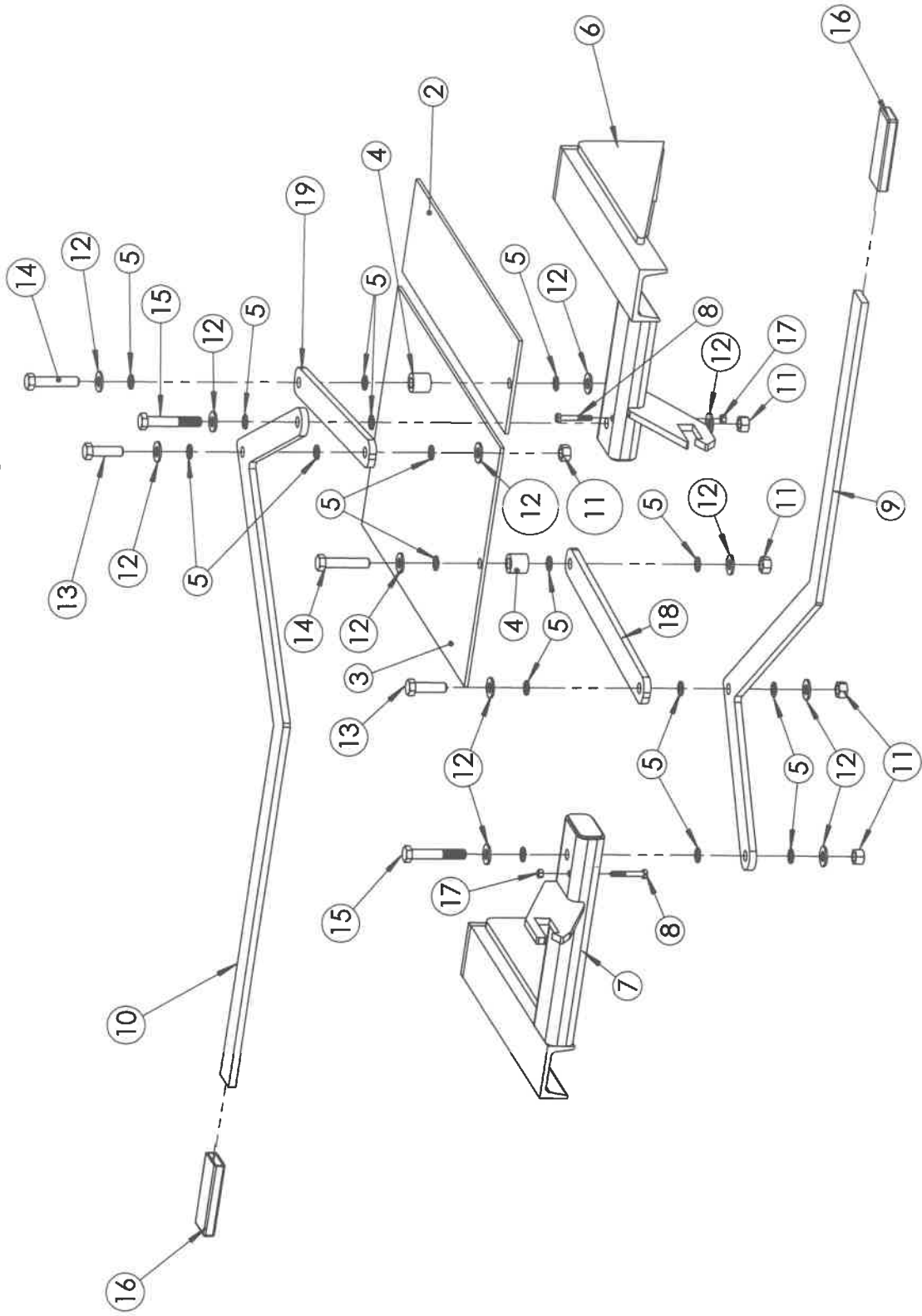

1612 SERIES TENDER SLIDE GATE UPGRADE INSTALLATION INSTRUCTIONS (P/N: 70573)

(REFERENCE ONLY)

(REFERENCE ONLY)

(REFERENCE ONLY)

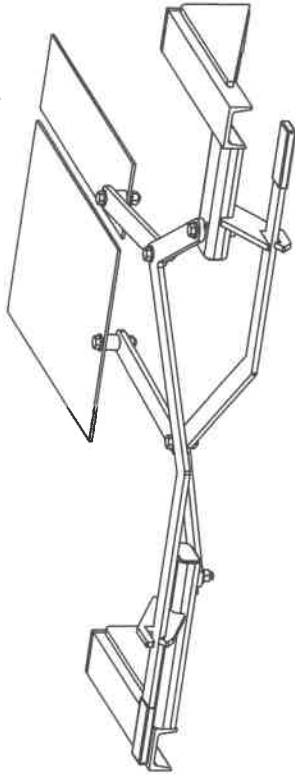

40C

ITEM NO.	PART NUMBER	DESCRIPTION	QTY.
1	48300119	BODY AND FRAME WELDMENT 409 SS	1
2	48300138	DISCHARGE GATE REAR 409 SS	1
3	48300065	DISCHARGE GATE, FRONT 409 SS	1
4	70574	SPACER	2
5	18984800	WASHER NYLON 1/2	18
6	70575	MOUNTING BRACKET RIGHT	1
7	70576	MOUNTING BRACKET LEFT	1
8	18470200	BOLT, HEX 1/4 X 2 NC SS	2
9	70577	DOOR LEVER	1
10	70578	DOOR LEVER RIGHT	1
11	18567400	NUT SS NYLOCK 1/2	6
12	18824800	WASHER FLAT 1/2 SS	12
13	18470175	BOLT SS CAP 1/2 X 1 3/4	2
14	18027436	BOLT SS CAP 1/2 X 2 1/2	2
15	18027438	BOLT, HEX 1/2 X 3 SS	2
16	54143A	HANDLE COVER	2
17	18569200	NUT 1/4 NYLOCK SS	2
18	70579	SLIDE GATE BAR LEFT	1
19	70580	SLIDE GATE BAR RIGHT	1

(LADDER MUST BE MOVED TO PASSENGER SIDE, OR AS SHOWN WITH CATWALK TO PREVENT INTERFERENCE)

1. REMOVE CRANK OPEN SLIDE GATE PACKAGE FROM TENDER (SEE PAGES 36-1-37-1 [ITEM 3A] & 38-1-39-1 IN THE MANUAL)
2. SET ASIDE THE FOLLOWING HARDWARE FROM PG 38-1 - 39-1, ITEMS 9,10, 10A,11
3. MOUNT MOUNTING BRACKETS ITEM 6 & 7 TO TENDER FRAME, SECURE USING HARDWARE SET ASIDE IN STEP 2
4. ATTACH DOOR LEVERS ITEMS 9 & 10 TO BRACKET AS SHOWN
5. ATTACH SLIDE GATES BARS ITEMS 18 & 19 TO GATES AS SHOWN
6. ATTACH SLIDE GATES BARS TO DOOR LEVERS AS SHOWN
7. OPEN AND CLOSE TO MAKE SURE GATES MOVE FREELY, AND DOOR LEVERS LOCK IN PLACE
8. TIGHTEN ALL HARDWARE

SERIES 1612 TENDER

BOX AND BOLT-ON ITEMS (2004 THRU SPRING 2010)

1612BXISO
08-26-10
01-30-14

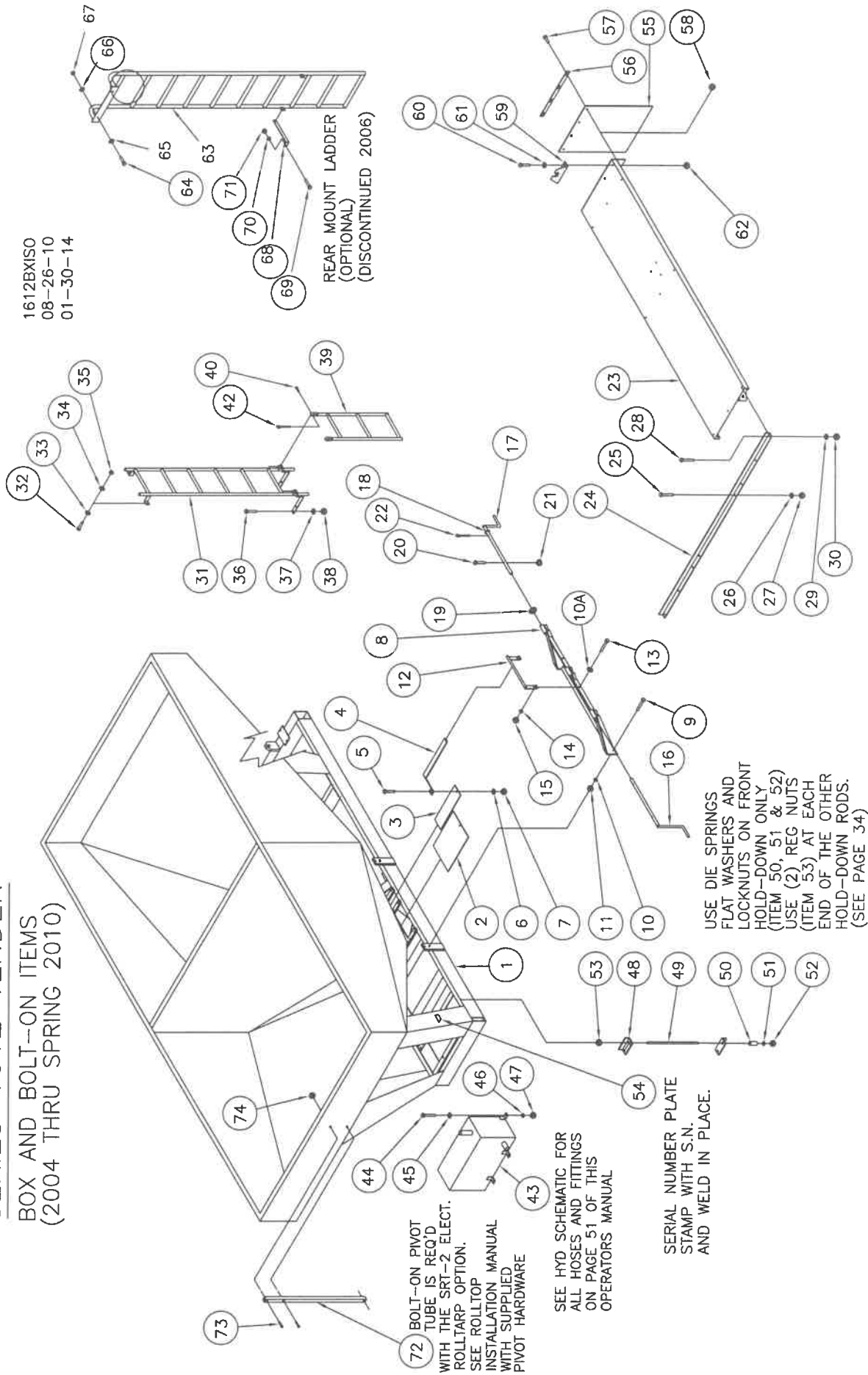

REAR MOUNT LADDER
(OPTIONAL)
(DISCONTINUED 2006)

72 BOLT-ON PIVOT
TUBE IS REQ'D
WITH THE SRT-2 ELECT.
ROLLTARP OPTION.
SEE ROLLTOP
INSTALLATION MANUAL
WITH SUPPLIED
PIVOT HARDWARE

SEE HYD SCHEMATIC FOR
ALL HOSES AND FITTINGS
ON PAGE 51 OF THIS
OPERATORS MANUAL

SERIAL NUMBER PLATE
STAMP WITH S.N.
AND WELD IN PLACE.

USE DIE SPRINGS
FLAT WASHERS AND
LOCKNUTS ON FRONT
HOLD-DOWN ONLY
(ITEM 50, 51 & 52)
USE (2) REG NUTS
(ITEM 53) AT EACH
END OF THE OTHER
HOLD-DOWN RODS.
(SEE PAGE 34)

SERIES 1612 TENDER

1612BXLST
08-26-10
REV 01-30-14

BOX AND BOLT-ON ITEMS
(2004 THRU SPRING 2010)

ITEM	PART NO.	DESCRIPTION	QTY	ITEM	PART NO.	DESCRIPTION	QTY
1	48300119	BODY AND FRAME WELDMENT	1	43	HYD. OIL TANK SEE HYDRAULIC ILLUSTRATION (SEE PAGE 51)	1	
2	48300065	DISCHARGE GATE, FRONT	1	44	BOLT, 3/8-16NC. X 1 1/4	ZC 4	
3	48300138	DISCHARGE GATE, REAR	1	45	FLAT WASHER, 3/8	ZC 4	
4	48300190	GATE ARM	2	46	LOCK WASHER, 3/8	ZC 4	
5	18022026	BOLT, 1/2-13NC. X 1 1/2	S.S. 2	47	HEX. NUT, 3/8-16NC.	ZC 4	
6	18991400	LOCK WASHER, 1/2	S.S. 2				
7	18997400	HEX. NUT, 1/2-13NC.	S.S. 2				
8	48300197	CRANK MOUNT WELDMENT	1	18384	BODY MOUNTING KIT COMPLETE		
9	18027417	BOLT, 1/2-13NC. X 2	S.S. 4	SEE ILLUSTRATION NO. (1612TRKMNT) FOR LOCATION			
10	18991400	LOCK WASHER, 1/2	S.S. 4	75739	HOLD-DOWN ANGLE	12	
10A	18824800	FLATWASHER, 1/2	S.S. 2	18386	HOLD-DOWN ROD	12	
11	18997400	HEX. NUT, 1/2-13NC	S.S. 4	50	DIE SPRING	4	
12	48300205	GATE ARM GUIDE	1	51	18851600	FLAT WASHER, 5/8	
13	18026824	BOLT, 3/8-16NC. X 1 1/4	S.S. 2	52	18457900	NUT, CENTER-LOCK, 5/8-11NC.	
14	18881201	LOCK WASHER, 3/8	S.S. 2	53	18417900	HEX. NUT, 5/8-11NC.	
15	18476800	HEX. NUT, 3/8-16NC	S.S. 2				
16	48300209	GATE CRANK, FRONT	1	30828	SERIAL NUMBER PLATE	1	
17	48300210	GATE CRANK, REAR	1				
18	18862200	FLAT WASHER, 1" SAE	S.S. 2	33243	MUD FLAP PACKAGE	2	
19	48300198	SPROCKET, #40x15T,(1" BORE)	2	32170A	MUD FLAP	2	
20	18026426	BOLT, 5/16-18NC. X 2	S.S. 2	47006302	MOUNTING STRAP	2	
21	18476351	LOCK-NUT, 5/16-18NC.	S.S. 2	18056824	BOLT, 3/8-16NC. X 1 1/4	ZC 8	
22	18570826	COTTER PIN, 3/16 X 1 1/2	S.S. 2	18496800	FLANGE NUT, 3/8-16NC	ZC 8	
23	1612TFP	FENDER PACKAGE INCL. ITEMS 23 TO 30	30	1612TLK	LIGHT KIT COMPLETE	1	
				47007356	TAIL LIGHT BRACKET	2	
24	48300224A	FENDER, L.H.	1	18026824	BOLT, 3/8-16NC. X 1 1/4	SS 4	
				18991200	FLAT WASHER,	SS 4	
25	48300062	FENDER MOUNT	3	18987900	FLANGE NUT, 3/8-16NC	SS 4	
26	18022026	BOLT, 1/2-13NC. X 1 1/2	SS 6				
27	18991400	LOCK WASHER, 1/2	SS 6	ALSO INCLUDES STANDARD LITE PKG. P.N. 28340 WITH			
28	18026824	HEX. NUT, 1/2-13NC.	SS 6	01836	TAIL LIGHT (R.H.) W/O LIC. LITE	1	
29	18991200	BOLT, 3/8-16NC. X 1 1/4	SS 18	01829	TAIL LIGHT (L.H.) W/ LIC. LITE	1	
30	18476800	LOCK WASHER, 3/8	SS 18				
				48300089	REAR LADDER OPT. (DISCONTINUED 2006)	1	
					INCLUDES ITEMS 63 TO 71		
31	1612TLAD	LADDER PACKAGE (ITEMS 31 THRU 42)	42	18996832	BOLT, 3/8-16NC. X 1 1/4	S.S. 2	
32	48300234	LADDER, SIDE MOUNT	1	18991200	FLAT WASHER, 3/8	S.S. 2	
33	18996832	BOLT, 3/8-16NC. X 1 1/4	S.S. 2	18881201	LOCK WASHER, 3/8	S.S. 2	
34	18991200	FLAT WASHER, 3/8	S.S. 2	18476800	HEX. NUT, 3/8-13NC.	S.S. 2	
35	18881201	LOCK WASHER, 3/8	S.S. 2	48300223	LADDER STAND-OFF BRACKET	2	
36	18476800	HEX. NUT, 3/8-13NC.	S.S. 2	18056824	BOLT, 3/8-16NC. X 1 1/4	ZC 4	
37	18996832	BOLT, 3/8-16NC. X 1 1/4	SS 4	18891200	LOCK WASHER, 3/8	ZC 4	
38	18881201	LOCK WASHER, 3/8	SS 4	18436800	HEX. NUT, 3/8-16NC.	ZC 4	
39	18476800	HEX. NUT, 3/8-16NC.	SS 4				
40	47007572	LADDER EXTENSION	1	OPT.	(Not Shown) ELECTRIC ROLL TARP	1	
41	18541430	CLEVIS PIN, 1/2 X 2	2	72	ROLL TARP PIVOT TUBE	1	
42	18560622	COTTER PIN, 1/8 X 1	2	73	BOLT, HX HD 3/8-16 X 1.50 SS	2	
				74	NUT, 3/8 - 16 SERRATED FLANGE SS	2	

SERIES 1612 TENDER 2010 and OLDER

BOX AND BOLT-ON ITEMS

(WITH 3 COMPARTMENTS OPTION)

16123CXISO
07-11-11
11-01-13

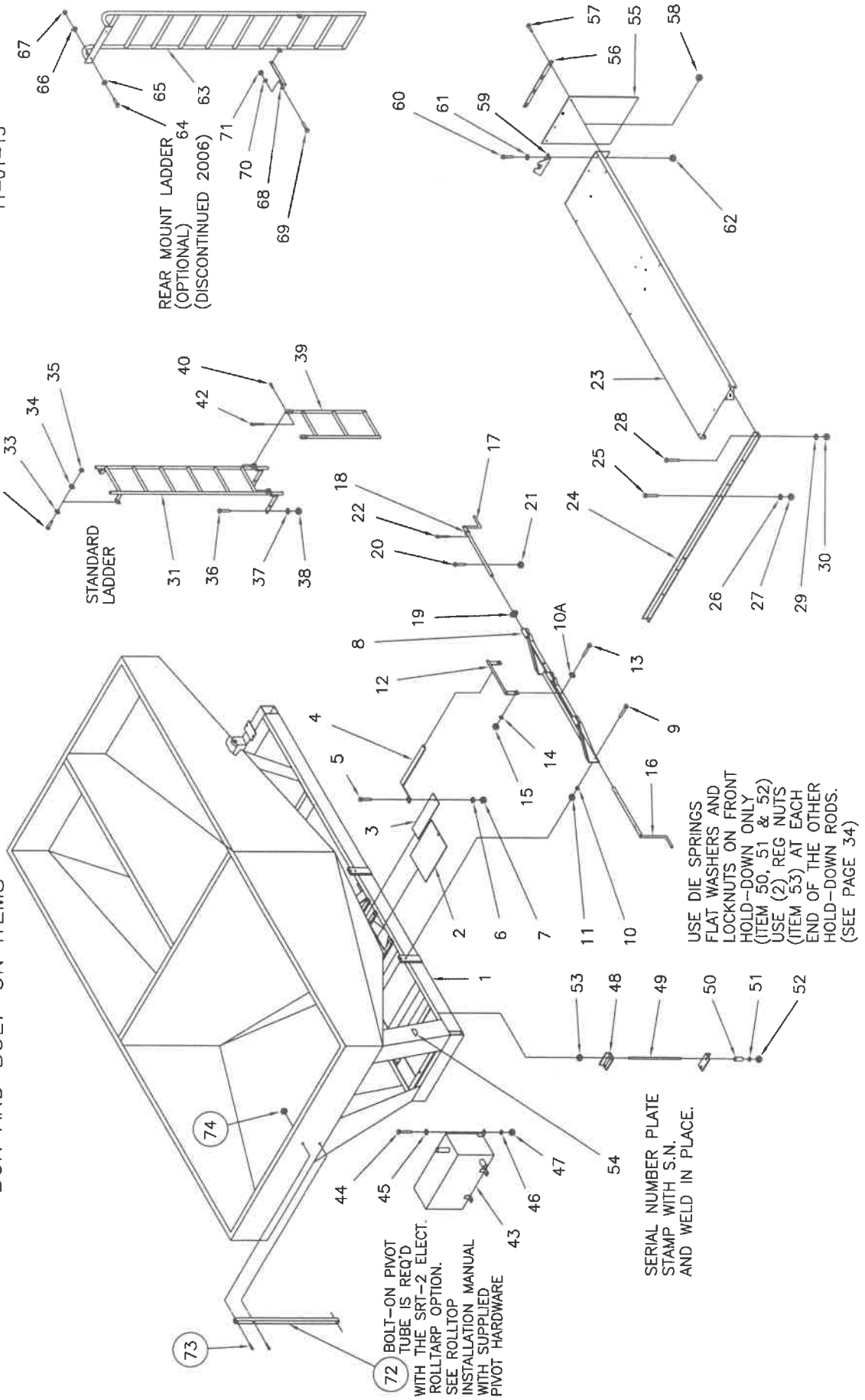

SERIES 1612 TENDER
(2010 and OLDER)
WITH 3 COMPARTMENT OPTION

16123CXLST
07-11-11
REV 01-30-14

BOX AND BOLT-ON ITEMS

ITEM	PART NO.	DESCRIPTION	QTY	ITEM	PART NO.	DESCRIPTION	QTY	
1	5178W	BODY AND FRAME WELDMENT	3 COMP.	43	HYD. OIL TANK	SEE HYDRAULIC ILLUSTRATION (PAGE 51)		
2	48300065	DISCHARGE GATE, FRONT	1	44	BOLT, 3/8-16NC. X 1 1/4	ZC	4	
3	5166	DISCHARGE GATE, REAR	2	45	FLAT WASHER, 3/8	ZC	4	
4	48300190	GATE ARM	4	46	LOCK WASHER, 3/8	ZC	4	
5	18022026	BOLT, 1/2-13NC. X 1 1/2	S.S.	47	HEX. NUT, 3/8-16NC.	ZC	4	
6	18991400	LOCK WASHER, 1/2	S.S.					
7	18997400	HEX. NUT, 1/2-13NC.	S.S.					
8	48300197	CRANK MOUNT WELDMENT	4	18384	BODY MOUNTING KIT COMPLETE			
9	18027417	BOLT, 1/2-13NC. X 2	S.S.		SEE ILLUSTRATION NO. (1612TRKMT) FOR LOCATION			
10	18991400	LOCK WASHER, 1/2	S.S.	48	HOLD-DOWN ANGLE		12	
10A	18524800	FLAT WASHER, 1/2	S.S.	49	HOLD-DOWN ROD		12	
11	18477400	HEX. NUT, 1/2-13NC	S.S.	50	DIE SPRING		4	
12	48300205	GATE ARM GUIDE	8	51	18851600	FLAT WASHER, 5/8	ZC	4
13	18026824	BOLT, 3/8-16NC. X 1 1/4	S.S.	52	18457900	NUT, CENTER-LOCK, 5/8-11NC.	ZC	8
14	18881201	LOCK WASHER, 3/8	S.S.	53	18449100	HEX. NUT, 5/8-11NC.	ZC	40
15	18476800	HEX. NUT, 3/8-16NC	S.S.					
16	48300209	GATE CRANK, FRONT	2	54	30828	SERIAL NUMBER PLATE	1	
17	48300210	GATE CRANK, REAR	1					
18	18862200	FLAT WASHER, 1" SAE	S.S.	55	33243	MUD FLAP PACKAGE	2	
19	48300198	SPROCKET, #40x15T,(1" BORE)	4	56	32170A	MUD FLAP	2	
20	18026426	BOLT, 5/16-18NC. X 2	S.S.	57	47006302	MOUNTING STRAP	8	
21	18476351	LOCK-NUT, 5/16-18NC.	S.S.	58	18056824	BOLT, 3/8-16NC. X 1 1/4	ZC	8
22	18570826	COTTER PIN, 3/16 X 1 1/2	S.S.		18496800	FLANGE NUT, 3/8-16NC	ZC	8
				1612TLK	LIGHT KIT COMPLETE			
23	48300224A	FENDER PACKAGE INCL. ITEMS 23 TO 30	30	59	47007356	TAIL LIGHT BRACKET	2	
				60	18026824	BOLT, 3/8-16NC. X 1 1/4	SS	4
				61	18991200	FLAT WASHER, 3/8	SS	4
24	48300062	FENDER MOUNT	3	62	18987900	FLANGE NUT, 3/8-16NC	SS	4
25	18022026	BOLT, 1/2-13NC. X 1 1/2	SS					
26	18991400	LOCK WASHER, 1/2	SS		ALSO INCLUDES STANDARD LITE PKG. P.N. 28340 WITH		1	
27	18997400	HEX. NUT, 1/2-13NC.	SS		01836	TAIL LIGHT (R.H.) W/O LIC. LITE	1	
28	18026824	BOLT, 3/8-16NC. X 1 1/4	SS		01829	TAIL LIGHT (L.H.) W// LIC. LITE	1	
29	18991200	LOCK WASHER, 3/8	SS	63	48300089	REAR LADDER,OPT. (DISCONTINUED 2006)	1	
30	18476800	HEX. NUT, 3/8-16NC.	SS			INCLUDES ITEMS 63 TO 71	2	
				64	18996832	BOLT, 3/8-16NC. X 1 1/4	S.S.	2
31	1612TLAD	LADDER PACKAGE (ITEMS 31 THRU 42)	42	65	18991200	FLAT WASHER, 3/8	S.S.	2
				66	18881201	LOCK WASHER, 3/8	S.S.	2
32	48300234	LADDER, SIDE MOUNT	1	67	18476800	HEX. NUT, 3/8-13NC.	S.S.	2
33	18996832	BOLT, 3/8-16NC. X 1 1/4	S.S.	68	48300223	LADDER STAND-OFF BRACKET	2	
34	18991200	FLAT WASHER, 3/8	S.S.	69	18056824	BOLT, 3/8-16NC. X 1 1/4	ZC	4
35	18881201	LOCK WASHER, 3/8	S.S.	70	18891200	LOCK WASHER, 3/8	ZC	4
36	18476800	HEX. NUT, 3/8-13NC.	S.S.	71	18436800	HEX. NUT, 3/8-16NC.	ZC	4
37	18996832	BOLT, 3/8-16NC. X 1 1/4	SS					
38	18881201	LOCK WASHER, 3/8	SS					
39	18476800	HEX. NUT, 3/8-16NC.	SS	OPT	SRT100200	(Not Shown) ELECTRIC ROLL TARP	OPT	
40	47007572	LADDER EXTENSION	4	72	47003956	ROLL TARP PIVOT TUBE	1	
41	18541430	CLEVIS PIN, 1/2 X 2	1	73	18026826	BOLT, HX HD 3/8-16 X 1.50	SS	2
42	OMITTED		2	74	18997900	NUT, 3/8-16 SERRATED FLANGE	SS	2

**SERIES 1612 TENDER
WITH 3 COMPARTMENT OPTION**
BOX AND BOLT-ON ITEMS
(FALL 2011 & NEWER)

1612BX3CIS02011
07-11-11
REV 05-27-15

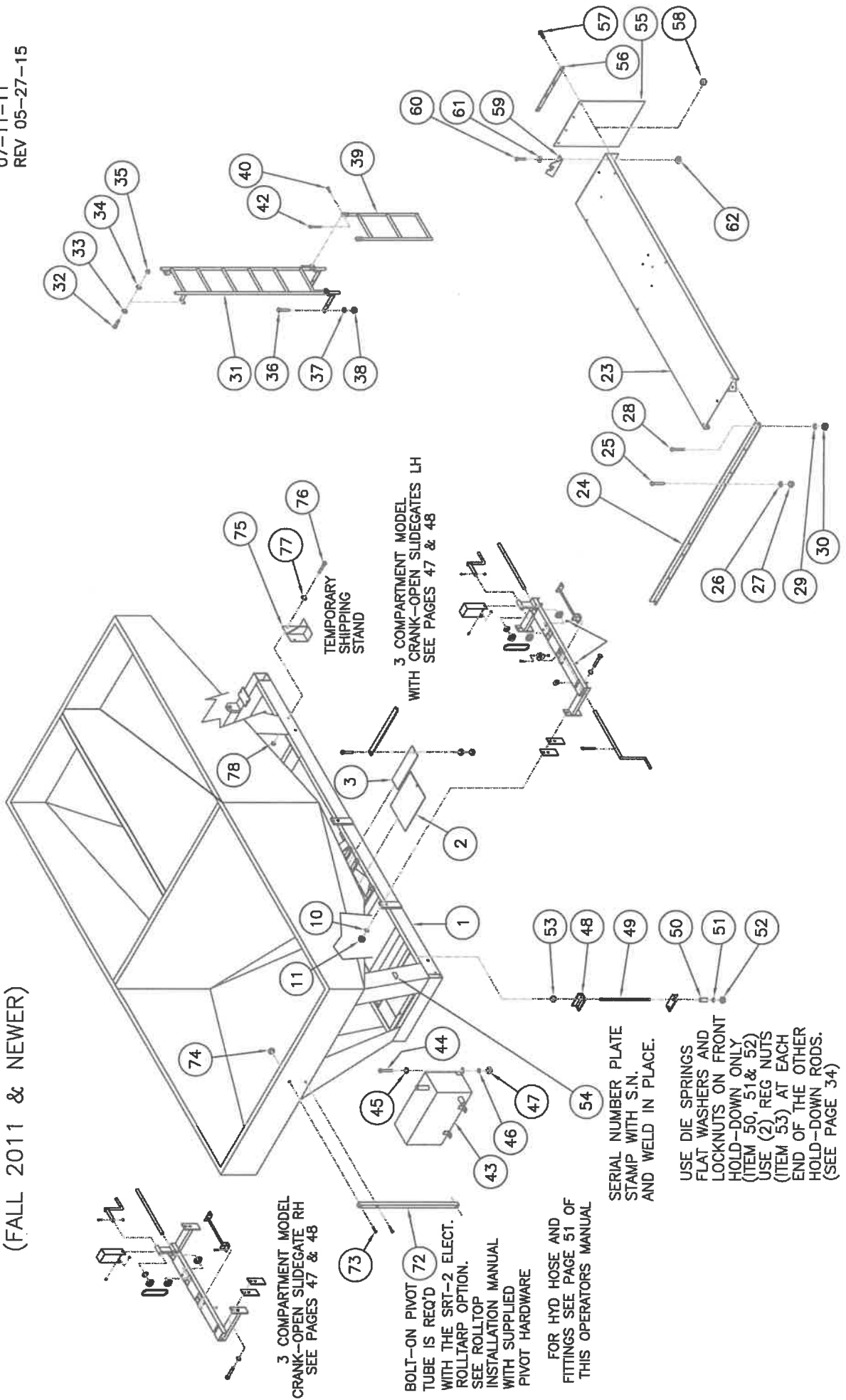

3 COMPARTMENT MODEL
CRANK-OPEN SLIDEGATE RH
SEE PAGES 47 & 48

TEMPORARY
SHIPPING
STAND

3 COMPARTMENT MODEL
WITH
CRANK-OPEN SLIDEGATES LH
SEE PAGES 47 & 48

BOLT-ON PIVOT
TUBE IS REQ'D
WITH THE SRT-2 ELECT.
ROLLTARP OPTION.
SEE ROLLTOP
INSTALLATION MANUAL
WITH SUPPLIED
PIVOT HARDWARE

SERIAL NUMBER PLATE
STAMP WITH S.N.
AND WELD IN PLACE.

USE DIE SPRINGS
FLAT WASHERS AND
LOCKNUTS ON FRONT
HOLD-DOWN ONLY
(ITEM 50, 51 & 52)
USE (2) REG NUTS
(ITEM 53) AT EACH
END OF THE OTHER
HOLD-DOWN RODS.
(SEE PAGE 34)

SERIES 1612 TENDER
(FALL 2011 & SPRING 2020)

1612BX3CLST
07-12-11
REV 08/13/19

WITH 3 COMPARTMENT OPTION
BOX AND BOLT-ON ITEMS

ITEM	PART NO.	DESCRIPTION	QTY	ITEM	PART NO.	DESCRIPTION	QTY
1	5178W	BODY AND FRAME WELDMENT 3 COMP.	1	43	HYD. OIL TANK SEE HYDRAULIC ILLUSTRATION (PAGE 51)	4	
2	48300065	DISCHARGE GATE, FRONT	1	44	BOLT, 3/8-16NC. X 1 1/4	4	
3	5166	DISCHARGE GATE, REAR	2	45	FLAT WASHER, 3/8	4	
4	47005543	SLIDE GATE BAR WELDMENT	3	46	LOCK WASHER, 3/8	4	
5				47	HEX. NUT, 3/8-16NC.	4	
6				18384	BODY MOUNTING KIT COMPLETE	4	
7					SEE ILLUSTRATION NO. (1612TRKMMT) FOR LOCATION		
8				48	HOLD-DOWN ANGLE	12	
8A				49	HOLD-DOWN ROD	12	
9				50	DIE SPRING	4	
10				51	FLAT WASHER, 5/8	4	
10A				52	NUT, CENTER-LOCK, 5/8-11NC.	8	
11				53	HEX. NUT, 5/8-11NC.	8	
12							
13				54	SERIAL NUMBER PLATE	1	
14							
15				33243	MUD FLAP PACKAGE	2	
16				76714	MUD FLAP	2	
17				56	MOUNTING STRAP	2	
18				57	BOLT, 3/8-16NC. X 1 1/4	8	
19				58	FLANGE NUT, 3/8-16NC	8	
19A							
19B				1612TLK	LIGHT KIT COMPLETE	2	
20				47007356	TAIL LIGHT BRACKET	4	
21				60	BOLT, 3/8-16NC. X 1 1/4	4	
22				61	FLAT WASHER, 3/8	4	
22A	47005734	CRANK MOUNT RH (CHAIN DRIVE)	1	62	FLANGE NUT, 3/8-16NC	4	
23	1612TFP	FENDER PACKAGE INCL. ITEMS 23 TO 30	1		ALSO INCLUDES STANDARD LITE PKG. P.N. 28340 WITH	1	
24	48300224A	FENDER, L.H.	1	01836	TAIL LIGHT (R.H.) W/O LIC. LITE	1	
25	48300225	FENDER, R.H.	1	01829	TAIL LIGHT (L.H.) W/ LIC. LITE	1	
26	48300062	FENDER MOUNT	3	63	REAR LADDER, OPT. (DISCONTINUED 2006)	1	
27	18022026	BOLT, 1/2-13NC. X 1 1/2	6		INCLUDES ITEMS 63 TO 71	1	
28	18991400	LOCK WASHER, 1/2	6	64	BOLT, 3/8-16NC. X 1 1/4	2	
29	18997400	HEX. NUT, 1/2-13NC.	6	65	FLAT WASHER, 3/8	2	
30	18026824	BOLT, 3/8-16NC. X 1 1/4	18	66	LOCK WASHER, 3/8	2	
31	18991200	LOCK WASHER, 3/8	18	67	HEX. NUT, 3/8-13NC.	2	
32	18476800	HEX. NUT, 3/8-16NC.	18	68	LADDER STAND-OFF BRACKET	2	
33	1612TLAD	LADDER PACKAGE (ITEMS 31 THRU 42)	1	69	BOLT, 3/8-16NC. X 1 1/4	4	
34	48300234	LADDER, SIDE MOUNT	1	70	LOCK WASHER, 3/8	4	
35	18026824	BOLT, 3/8-16NC. X 1 1/4	2	71	HEX. NUT, 3/8-16NC.	4	
36	18991200	FLAT WASHER, 3/8	2				
37	18881201	LOCK WASHER, 3/8	2	OPT	SRT100200	1	
38	18476800	HEX. NUT, 3/8-16NC.	2	72	ROLL TARP PIVOT TUBE	1	
39	47007572	LADDER EXTENSION	1	73	BOLT, HX HD. 3/8-16 X 1.50 SS	2	
40	18541430	CLEVIS PIN, 1/2 X 2	2	74	NUT, 3/8-16 SERRATED FLANGE SS	2	
41	OMITTED			75	SHIPPING STAND	4	
42	18560622	COTTER PIN, 1/8 X 1	2	76	BOLT, 1/2-13NC. X 1 1/4	4	
				77	FLAT WASHER, 1/2	8	
				78	LOCK NUT, 1/2-13NC.	8	

ITEMS 75 TO 78 ARE USED FOR STORAGE AND TRANSPORT ONLY. MAY BE RETURNED FOR CREDIT.

FOR SLIDE GATE ITEMS 5 THRU 22
SEE PAGES 47 AND 48
OF THIS OWNERS MANUAL

SERIES 1612 TENDER
3 COMPARTMENT ONLY
(FALL 2011 & NEWER)

BOX AND BOLT-ON ITEMS
CRANK-OPEN SLIDEGATES

16123CGATES
07-12-11

DRIVEN BY SPROCKETS
BOLT ON TO SLIDEGATE BUT KEEP
SLIGHTLY LOOSE TO ALLOW MOVEMENT
AND DOUBLE NUT LOCK AGAINST EACH OTHER
SEE INSTALLATION INSTRUCTIONS

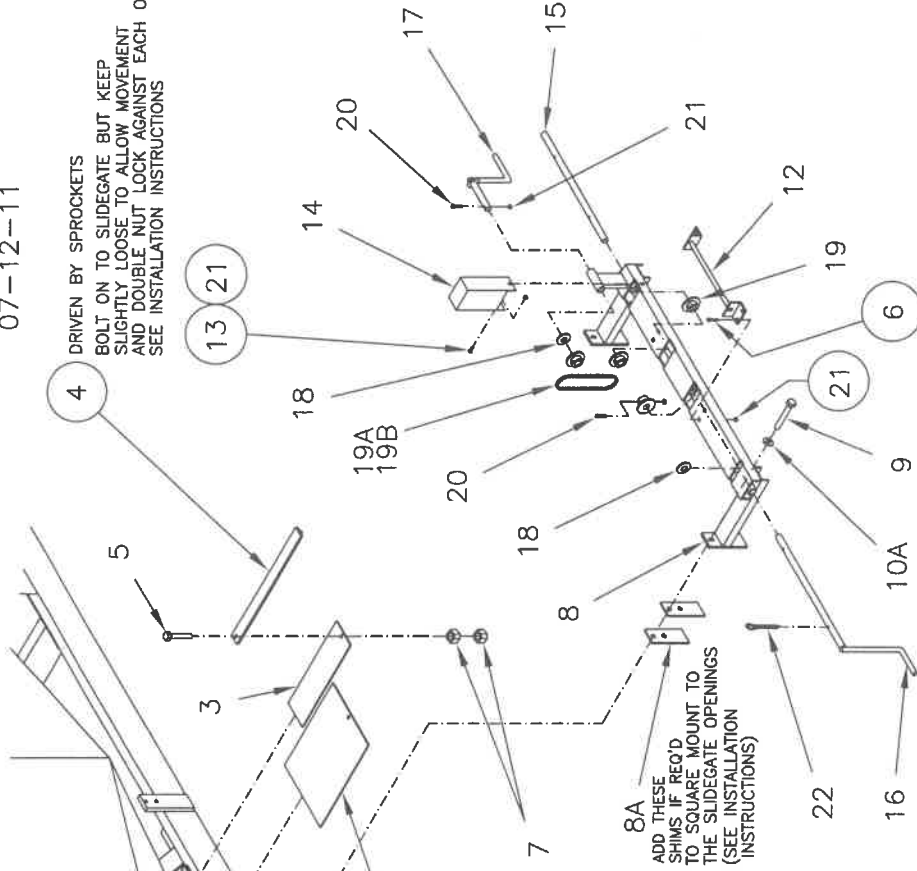

STANDARD CRANK OPEN SLIDEGATE ASSY
MOUNTS TO LH SIDE OF 3 COMP'T UNIT
(OPENS TWO GATES ON LH SIDE)

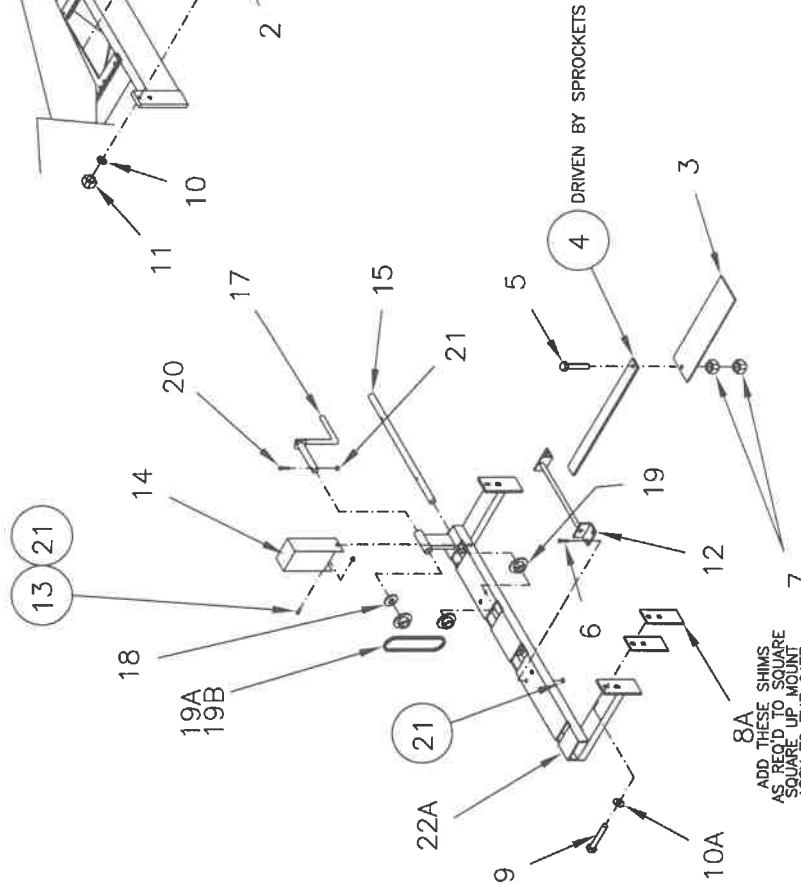

3 COMPARTMENT ONLY MODEL
MOUNTS TO RH SIDE OF 3 COMP'T UNIT
(OPENS SINGLE GATE ON RH SIDE)

SERIES 1612 TENDER

16123CGATLST
07-12-11

3 COMPARTMENT TENDER
CRANK-OPEN SLIDEGATE PACKAGE
(FALL 2011 & NEWER)

<u>ITEM</u>	<u>PART NO.</u>	<u>DESCRIPTION</u>	<u>QTY</u>
4	47005543	SLIDEGATE BAR WELDMENT	3
5	18027417	BOLT, 1/2-13NC. X 2	3
6	18026424	BOLT, 5/16-18 NC. X 1 1/4	8
7	18997400	HEX. NUT, 1/2-13NC.	6
8	47005532	CRANK MOUNT WELD'T LH (CHAIN DRV)	1
8A	47005531	CRANK MOUNT SHIM PLATE	8
9	18027417	BOLT, 1/2-13NC. X 2	8
10	18991400	LOCK WASHER, 1/2	8
10A	18824800	FLATWASHER, 1/2	4
11	18997400	HEX. NUT, 1/2-13NC	8
12	47005542	GUIDE BAR WELDMENT (FOR CHAIN DRV)	2
13	18026418	BOLT, 5/16-18 NC. X 3/4	4
14	47005557	CHAIN GUARD WELDMENT	2
15	47005536	SHAFT LOWER RH	2
16	48300209	GATE CRANK, FRONT	1
17	47005533	GATE CRANK, RH	2
18	18862200	FLAT WASHER, 1" SAE	2
19	48300198	SPROCKET, #40x15T,(1" BORE)	7
19A	300191	CHAIN, #40 SS X 19 7/8" LONG	2
19B	31028	CONNECTING LINK, #40 SS	2
20	18026426	BOLT, 5/16-18NC. X 2	7
21	18476351	LOCK-NUT, 5/16-18NC.	17
22	18570826	COTTER PIN, 3/16 X 1 1/2	1
22A	47005734	CRANK MOUNT WELD'T RH (CHAIN DRV)	1

**SERIES 1612 TENDER
REAR DISCHARGE AUGER**

1612AGRISO
11-17-11
REV 08-12-15

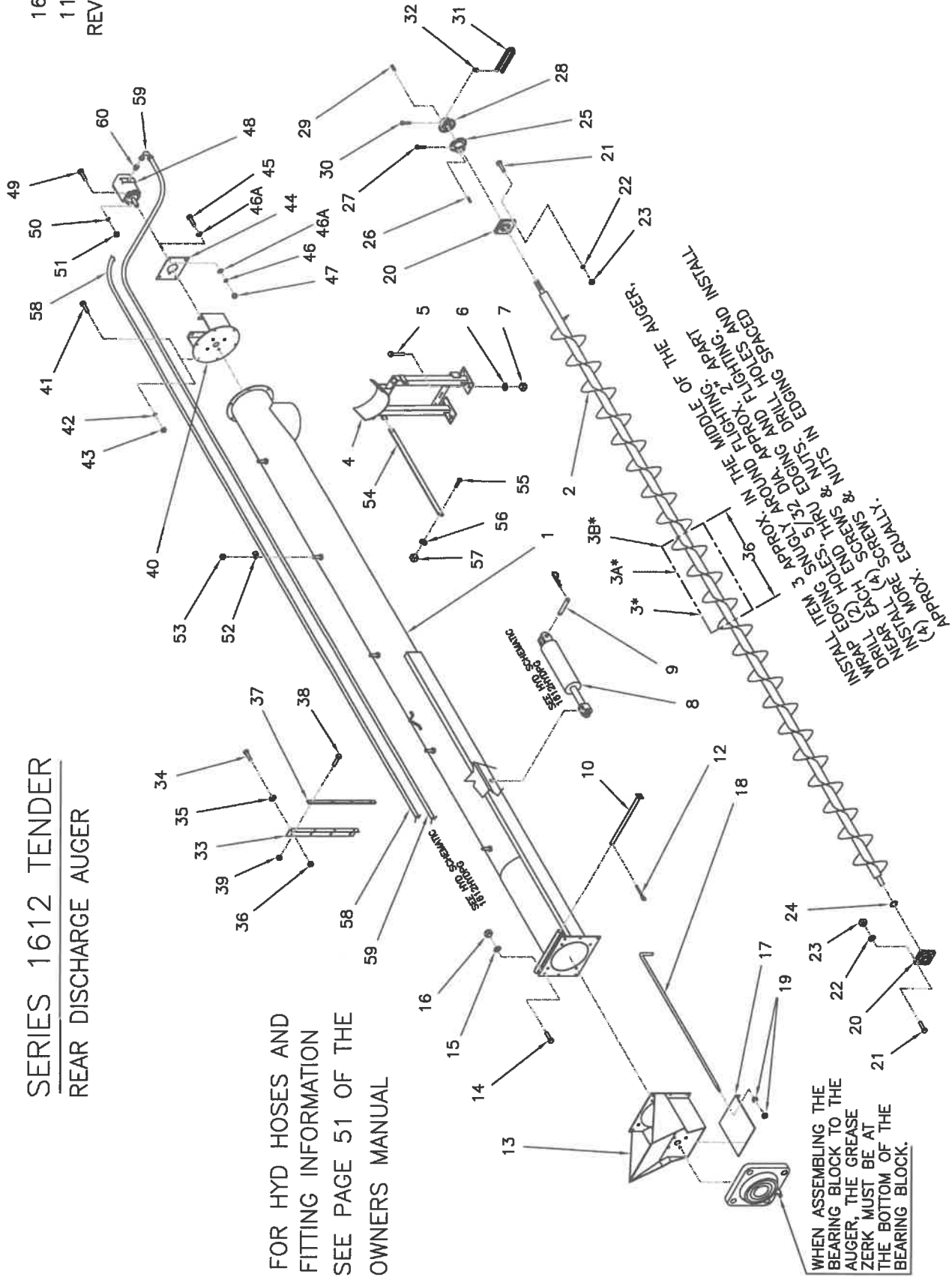

FOR HYD HOSES AND
FITTING INFORMATION
SEE PAGE 51 OF THE
OWNERS MANUAL

INSTALL ITEM 3 APPROX IN THE MIDDLE OF THE AUGER,
DRILL HOLES 5/32 DIA APPROX 2" APART
NEAR EACH END THRU EDGING AND FLIGHTING
INSTALL (4) MORE SCREWS & NUTS IN EDGING SPACES AND INSTALL
APPROX. EQUALLY.

WHEN ASSEMBLING THE
BEARING BLOCK TO THE
AUGER, THE GREASE
ZERK MUST BE AT
THE BOTTOM OF THE
BEARING BLOCK.

SERIES 1612 TENDER
DISCHARGE AUGER PARTS LIST

ITEM	PART NO.	DESCRIPTION	QTY	ITEM	PART NO.	DESCRIPTION	QTY
1	48300239S 48300114	AUGER TUBE WELD. (21 1/2 FT. AUGER) 304 SS 1 AUGER TUBE WELD. (20 FT. AUGER)	1	28	10183	SPROCKET, 50B24, 1" BORE X 1/4 K'WAY	1
2	48300241 48300154	AUGER SCREW ASSEMBLY, (21 1/2 FT. AUGER) 1 AUGER SCREW ASSEMBLY, (20 FT. AUGER)	1	29	47006519	DRIVE KEY, 1/4 SQ. X 2	1
3	* 300250	UHMW EDGING, 10 LINEAR FT SECTION *	*	30	18767450	SET SCREW, 5/16-18NC. X 3/4, SQ HEAD	2
3A	* 18704218	SCREW, #8-32 X 3/4 RD. HD. S.S. (8 REQ'D) *	*	31	29941	COUPLING CHAIN,	1
3B	* 18474201	LOCKNUT, #8-32 NYLON S.S. (8 REQ'D) *	*	32	53159	SPLICE LINK	1
		* THESE ITEMS ARE INCLUDED WITH AUGER SCREW ASSEMBLY BUT MAY BE ORDERED SEPARATELY AS REPLACEMENT PARTS		33	48399157	WEAR STRIP MOUNT KIT (ITEMS 33 THRU 39)	2
4	48399179 48300179	AUGER CRADLE KIT (ITEMS 5 THRU 7 & 55 THRU 57) 1 AUGER CRADLE	1	34	48300157	MOUNT FOR WEAR STRIP	8
5	18057426	BOLT, 1/2-13NC. X 1 1/2	4	35	18026824	BOLT, 3/8-16NC. X 1 1/4	8
6	18991400	LOCK WASHER, 1/2	4	36	18991200	FLAT WASHER, 3/8	8
7	18417400	HEX. NUT, 1/2-13NC (SET OF 2)	4	37	18987900	FLANGE NUT, 3/8-16NC.	8
8	HYD. CYL. (3 X 12)	SEE HYDRAULIC SCHEMATIC 1612HYDPG	1	38	48300158	WEAR STRIP, AUGER GUIDE	2
9	47003513	CYLINDER PIN KIT.	1	39	18799200	MACHINE SCREW, 1/4-20NC. X 1	8
10	48300196	AUGER PIVOT PIN	1	40	18569200	HEX. LOCK NUT, W/NYLON INSERT	8
11	OMITTED			41	48300055	END CAP, AUGER 409 SS	1
12	18560826	COTTER PIN, 3/16 X 1 1/2	1	42	18026824	END CAP, AUGER 304 SS	6
13	48300096	BOOT WELDMENT 409 SS	1	43	18881201	BOLT, 3/8-16NC. X 1 1/4	6
14	48300096S	BOOT WELDMENT 304 SS	1	44	18476800	LOCK WASHER, 3/8	6
15	18475240	BOLT, 1/2-13NC. X 1 1/4	10	45	48300058	HEX. NUT, 3/8-16NC.	1
16	18991400	LOCK WASHER, 1/2	10	46	18475240	MOTOR MOUNT PLATE, (2 BOLT MOTOR)	4
17	18997400	HEX. NUT, 1/2-13NC.	10	47	18991400	BOLT, 1/2-13NC. X 1 1/4	4
		CLEAN-OUT DOOR		48	18824800	LOCK WASHER, 1/2	8
18	48300073	PULL ROD, CLEAN-OUT DOOR	1	49	18997400	HEX. NUT, 1/2-13NC.	4
19	18997400	HEX. NUT, 1/2-13NC.	2	50	HYD. MOTOR	(SEE HYD SCHEMATIC 1612HYDPG)	1
20	52065	BEARING, W/4-BOLT FLANGE	2	51	18470175	BOLT, 1/2-13NC. X 1 3/4	2
21	18470175	BOLT, 1/2-13NC. X 1 3/4	8	52	18991400	LOCK WASHER, 1/2	2
22	18991400	LOCK WASHER, 1/2	8	53	18997400	HEX. NUT, 1/2-13NC.	2
23	18997400	HEX. NUT, 1/2-13NC.	8	54	41771	HOSE CLAMP, 1 1/8 I.D. VINYL COATED	10
24	18300323	THRUST WASHER, (1 1/2 X 10 ga. MACH. WSHR)	1	55	18987900	FLANGE NUT, 3/8-16NC.	5
25	48300161	SPROCKET, 50B24, 1 1/2 BORE X 3/8 K'WAY	1	56	48300250	BRACE, AUGER CRADLE	2
26	1711	DRIVE KEY, 3/8 SQ. X 2	1	57	18475240	BOLT, 1/2-13NC. X 1 1/4	4
27	18767326	SET SCREW, 3/8-16NC. X 3/4, SQ HEAD	2	58	18991400	LOCK WASHER, 1/2	4
				59	18997400	HEX. NUT, 1/2-13NC.	4
				60	612333	HOSE ASSY 3/4 X 333" (SEE HYD SCHEMATIC 1612HYDPG)	1
					612276	HOSE ASSY 3/4 X 276" (SEE HYD SCHEMATIC 1612HYDPG)	1
					6400-12	STRAIGHT ADAPTER (SEE HYD SCHEMATIC 1612HYDPG)	2

SERIES 1612 TENDER

HYDRAULIC SCHEMATIC

1612HYDPG
rev 08/13/19

ITEM	PART NO.	DESCRIPTION	QTY	ITEM PART NO.	DESCRIPTION	QTY
1	48300227	CONTROL VALVE (WITH HANDLES ETC)	1	601612	HOSE PKG. (21 1/2FT AUGER) ITEMS 20 TO 26	1
2	51930	MOTORCHAR-LYNN 104-1041-006	1	612171	HOSE, 3/4 X 171"	3/4 M PIPE X #12 JIC90
3	47005489	HYDRAULIC CYLINDER, 3 X 12	1	612132	HOSE, 3/4 X 132	#12 JIC SWVL X #12 JIC90
4	47003513	CYLINDER PIN KIT, (1 X 3 1/2) W CYL	1	612276	HOSE, 3/4 X 276"	#12 JIC SWVL X #12 JIC90
5	01170	FILTER, COMPLETE W ELEMENT	1	612333	HOSE, 3/4 X 333"	#12 JIC SWVL X #12 JIC90
6	11128	FILTER ELEMENT ONLY	1	606072	HOSE, 3/8 X 72"	#6 JIC SWVL EA. END
7	38711	HYDRAULIC OIL TANK	1	606090	HOSE, 3/8 X 90"	#6 JIC SWVL EA. END
8	02153	DIP STICK	1	612060	HOSE, 1/4 X 60"	1/8 M PIPE EA. END
9	18056834	BOLT, 3/8-16NC. X 2 1/2	3	OPTIONAL-	FOR 20 FT. AUGER REPLACE ITEMS 22 & 23 WITH	
10	18811200	FLAT WASHER, 3/8	3	612258	HOSE, 3/4 X 258"	#12 JIC SWVL X #12 JIC90
11	18436800	HEX. NUT, 3/8-16NC.	3	612315	HOSE, 3/4 X 315	#12 JIC SWVL X #12 JIC90
12	48300092	VALVE SPACER	3	611612	FITTING PACKAGE, INCL. ITEMS 27 TO 35	1
13	28882A	DECAL, CONTROL VALVE	1	306338	PLUG, O-RING TYPE	1
14	02006	GATE VALVE, 1 1/4 NPT	1	6400-12	ADAPTER	4
15	72368	HOSE BARB, 1 1/4 HOSE X 1 1/4 NPT	1	445001	ADAPTER ELBOW	1
16	51191**	HOSE, SUCTION, 1 1/4 I.D. X 80"	2	6801-6-12	ADAPTER, ELBOW	2
17	200254**	HOSE CLAMP	1	2605-12-12	RUN TEE	1
18	72175	PLUG, OILTANK 1/2" NPT	1	6801-6-8	ADAPTER, ELBOW	2
19	28223	DECAL, DRAIN OIL	1	1404-2-2	ADAPTER, ELBOW	1
19A	276534	DECAL, HYDRAULIC OIL	1	51933	HEX PIPE NIPPLE, (5404-16-12)	1
		** OPTIONAL		5405-04/28-02	ADAPTER, 1/4-28M 1/8"-27 PIPEF	1
				48300229	LOCK-OUT, VALVE HANDLE	1

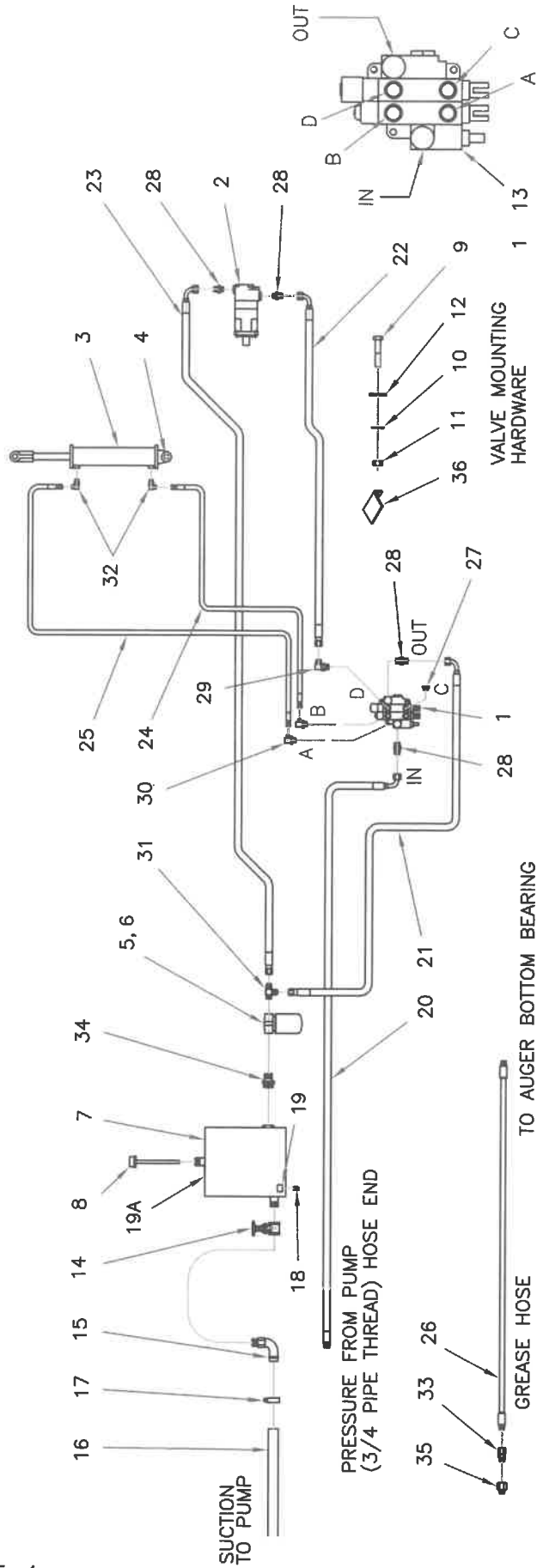

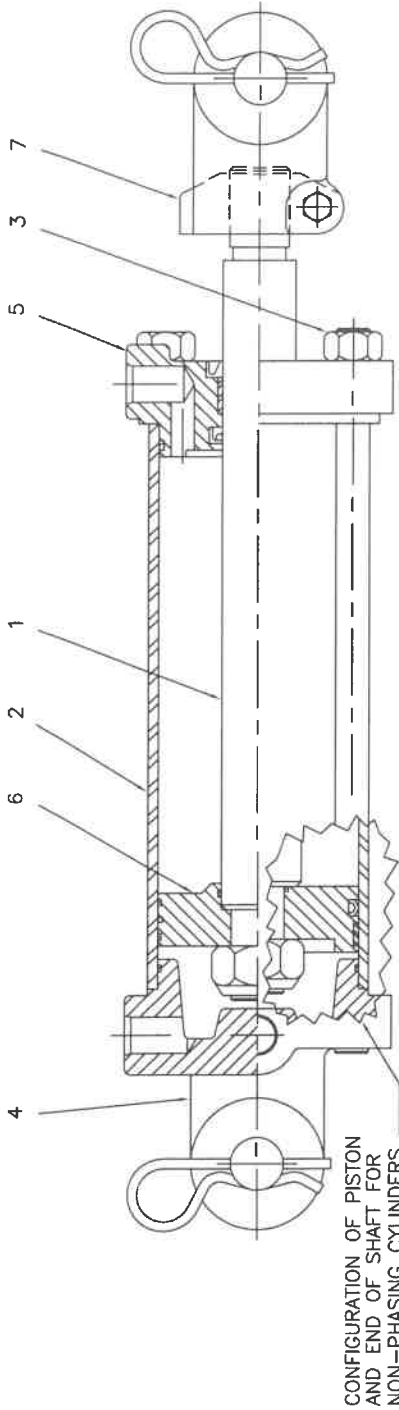

CONFIGURATION OF PISTON AND END OF SHAFT FOR NON-PHASING CYLINDERS

ITEM NO.	DESCRIPTION	AUGER LIFT CYL. REQ'D.	QTY.
1	SHAFT	3 X 12	1
2	TUBE	47005489	1
3	TIE ROD ASSM.	B300120BBAA07F	4
4	BUTT	010717750A	1
5	GLAND ASSM.	051514063A	1
6	PISTON	170201162	4
7	CLEVIS ASSM. REPAIR KIT	1415005SF	1
		0815BBGSF	1
		071500244	1
		100000423	1
		47033000	1

Repair kit items not available individually.

TIE ROD DISASSEMBLY--/ASSEMBLY PROCEDURE.

With the cylinder removed from the machine, cleaned, drained of oil and fully retracted, proceed as follows.

DISASSEMBLY.

1. Secure the cylinder in a vice or other method to prevent rotation. Clean the immediate area so the parts can be laid out.
2. Remove the tie rod nuts. Pull the shaft assembly from the cylinder. Remove the tube item (2).
3. Loosen the clevis nut and remove the clevis item (7) from the shaft assembly.
4. Place the shaft assembly in a vice with brass or copper jaws so as not to damage the shaft.
5. Remove all seals from the butt, (item 4) gland assembly, (item 5) and piston (item 6) for replacement. Clean and inspect all parts for damage, (nicks, scratches, cracks etc.). Replace as necessary. If you have any question please contact Prince Engineering (712-277-4061)

REASSEMBLY.

1. Replace all the seals on items (4), (5), and (6) except, for non-phasing cylinders do not replace the small o-ring on the ID of the piston item (6) until you are ready to attach the shaft item (1).
2. For non-phasing cylinders, place the small o-ring seal for the piston over the shaft turnaround. Apply a light coat of grease to the seal. Slip the piston item (6) onto the turnaround with the o-ring counterbore towards the shaft shoulder. Take care not to pinch the o-ring between the piston and the shoulder.
3. Replace the shaft end nut and secure.
4. Apply a light coat of grease to the seals on the gland item (5) and slip the gland over the shaft end. Be very careful not to damage the seals. Slip the entire assembly into the lightly oiled tube, item (2) with the piston first making sure the tube slips over the OD seals of the gland.
5. Take the entire assembly from step 4 and slip the tube over the OD seal on the butt item (4). Align the ports in the butt and the gland and assemble the nuts to the tie rods and torque uniformly.
6. Torque shaft locknut to 265 +/- 10 ft/lbs.. Torque tie rods to 60 +/- ft/lbs.. Set retract and torque clevis bolt to 28 +/- 2 ft/lbs..
7. Test the reassembled cylinder for leaks and install in your machine. If you have any problems please contact Prince Engineering (712-277-4061)

28340 LIGHT KIT

WIRING DIAGRAM

MT8, MT10, MT16, MT24, MT32

ITEM	QTY	PARTNUMBER	DESCRIPTION
1	1	57177	WIRE HARNESS W LOOM
2	1	57175	WIRE HARNESS W LOOM
3	1	01836	TAIL-LIGHT RH W/O LIC.
4	1	01829	TAIL-LIGHT W LIC ILL..
5	3	18103	CLEARANCE LIGHT, RED
6	2	18104	CLEARANCE LIGHT, AMBER
7	4	42448	BUTT CONNECTER
8	1	57180 REF	WIRE, 14GA BROWN
9	1	57181 REF	LOOM
10	1	57151 REF	WIRE, 14GA BROWN
11	1	57140 REF	LOOM
12	1	57183	QUICK SPLICE

NOTE: FAR LED LIGHTS ON THE TRUCK NEEDS EITHER AN LED FLASHER, OR A 50 WATT 6 OHM RESISTOR ADDED TO THE WIRE HARNESS

NOTE: CUT 48" END TO DESIRED LENGTH AND ADD CONNECTOR

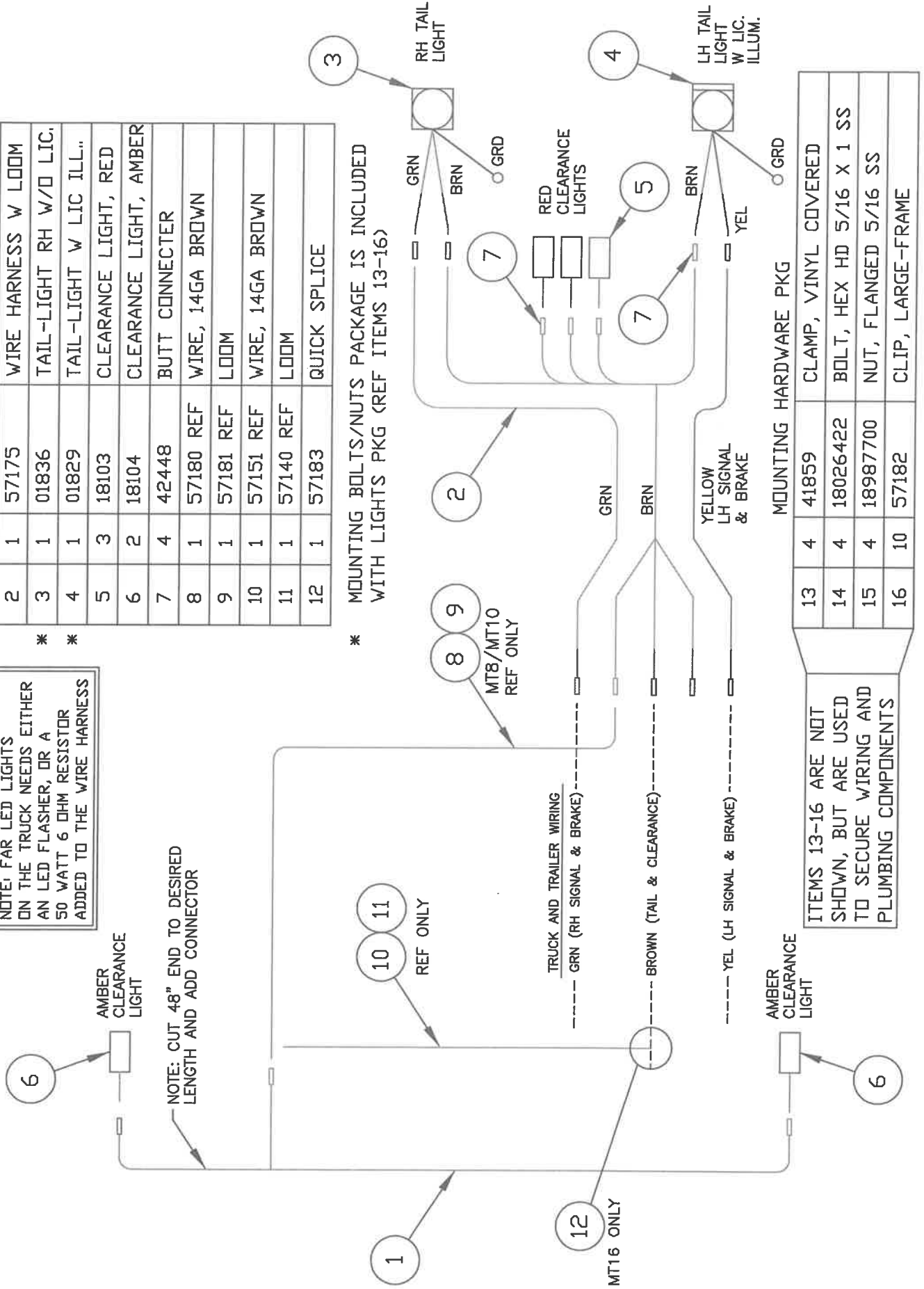

* MOUNTING BOLTS/NUTS PACKAGE IS INCLUDED WITH LIGHTS PKG (REF ITEMS 13-16)

MOUNTING HARDWARE PKG

13	4	41859	CLAMP, VINYL COVERED
14	4	18026422	BOLT, HEX HD 5/16 X 1 SS
15	4	18987700	NUT, FLANGED 5/16 SS
16	10	57182	CLIP, LARGE-FRAME

ITEMS 13-16 ARE NOT SHOWN, BUT ARE USED TO SECURE WIRING AND PLUMBING COMPONENTS

ARCH DIVIDER LAYOUT & PARTS LISTING

ARCH DIVIDER
06/04/19

(1612)

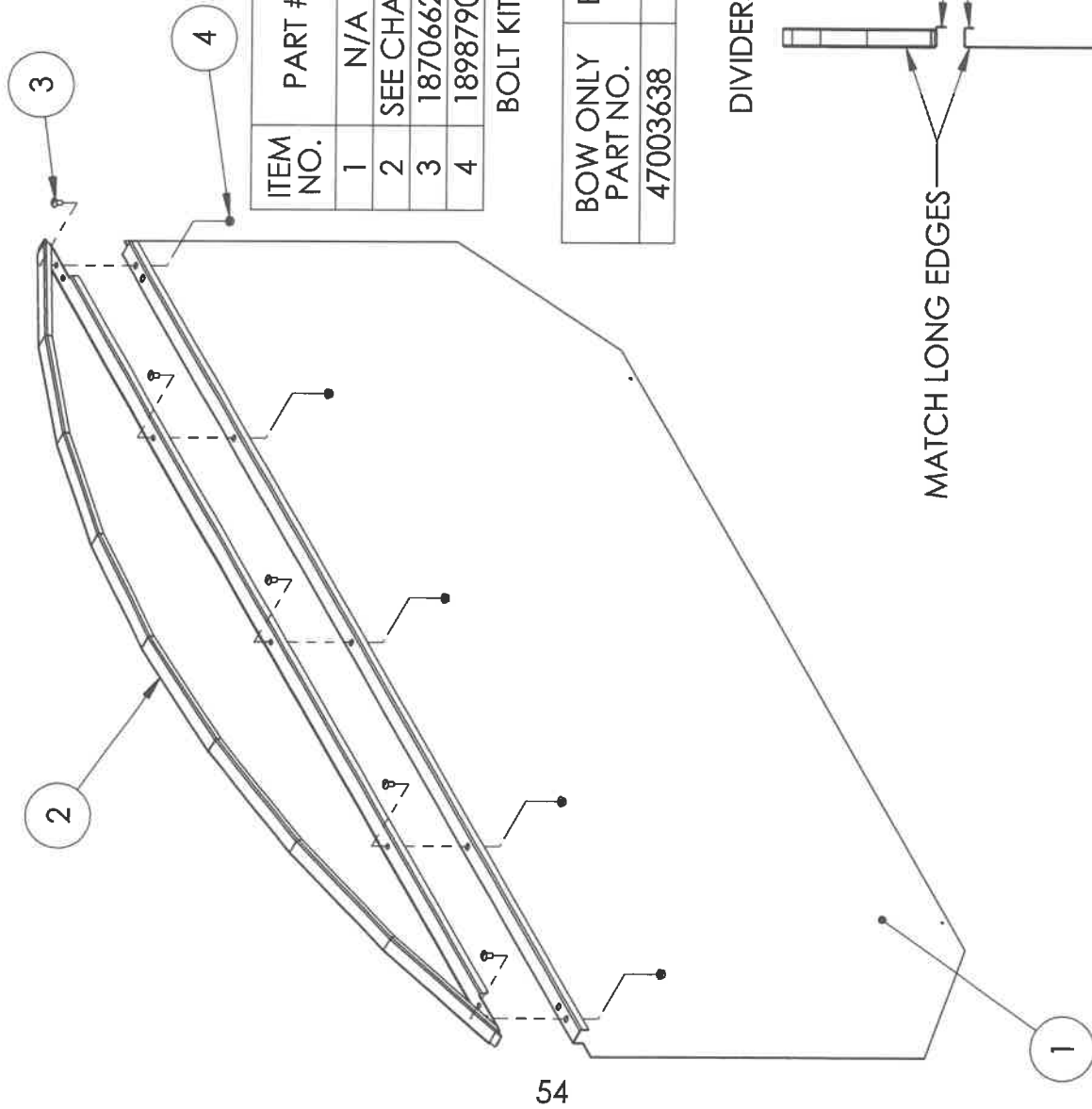

ITEM NO.	PART #	DESCRIPTION	QTY
1	N/A	DIVIDER PANEL(ON TENDER)	N/A
2	SEE CHART	BOW DIVIDER	1
3	18706621	SCREW, SLOTTED TRUSS HEAD 3/8 X 3/4 S.S.	5
4	18987900	NUT, SER. FLG. S.S. 3/8	5

BOLT KIT P/N: 47883641 CONTAINS ITEMS 3 AND 4

BOW ONLY PART NO.	BOW W/ HARDWARE PART NO.	FITS UNIT
47003638	47993638	1612 (12" HIGH ARCH)

DIVIDERS ARE ORDERED INDIVIDUALLY

1612 W/ SINGLE VIBRATOR PARTS LIST

(PRE 2020) (VIBCO)
P/N: 4701DC700

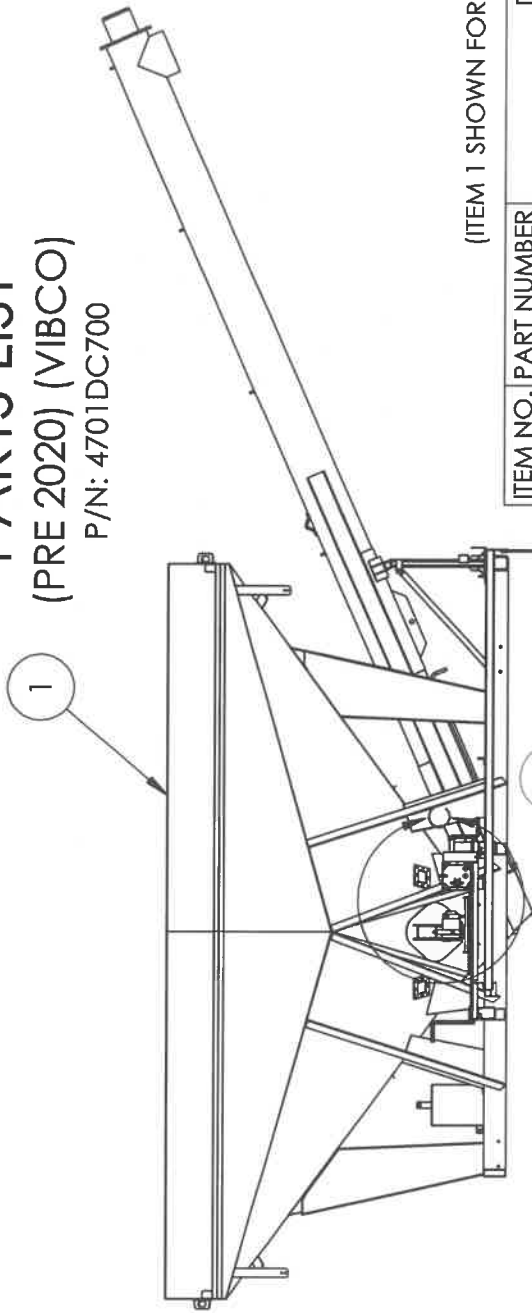

(ITEM 1 SHOWN FOR REFERENCE ONLY)

ITEM NO.	PART NUMBER	DESCRIPTION	QTY.
1	1612 tender	1612 MOUNTED WITH FENDERS	1
2	DC-700	VIBRATOR	1
3	77002	4-PORT SOLENOID	1
4	18000049	SELECTRA SWITCH SS206A-BG	1
5	18000046	SELECTRA SWITCH SS206A-BG	1
6	18000041	1/2 CGB CG5050	2
7	47007997	VIBRATOR MOUNTING PAD	1
8	18000047	SCEPTER JBX 6X6X4 (COVER NOT SHOWN)	1
9	41859	CLAMP VINYL COVERED 9/16 .343 HOLE	1
10	18026422	BOLT CAP SS 5/16 X 1	1
11	18987700	NUT 5/16 SERR FLG	1
12	18000050	BOLT AH SS 1/4 X 3/4	2
13	18569200	NUT 1/4 NYLOCK SS	2
14	18026822	BOLT, HEX HD 3/8 X 1 NC SS	2
15	18987900	NUT SER FLG SS 3/8	2
16	18991200	WASHER FLAT 3/8 SS	2

ALSO REQUIRED BUT NOT SHOWN:
20046 - WIRE 6 GA 2 STRAND - 14 FT

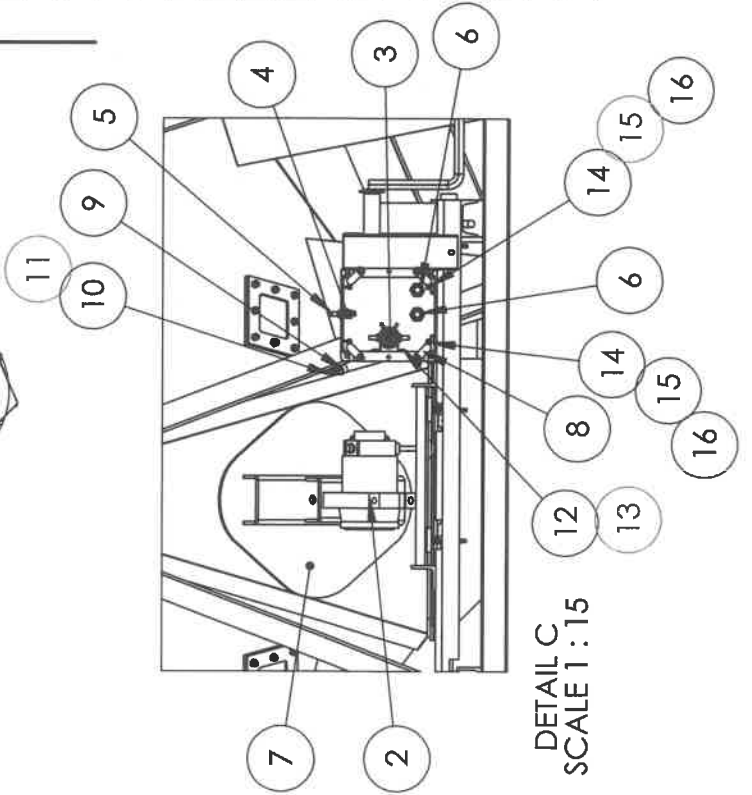

1612 W/ SINGLE VIBRATOR CONNECTION DIAGRAM

(PRE 2020) (VIBCO)

P/N: 4701DC700

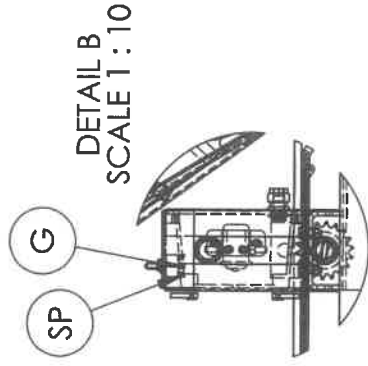
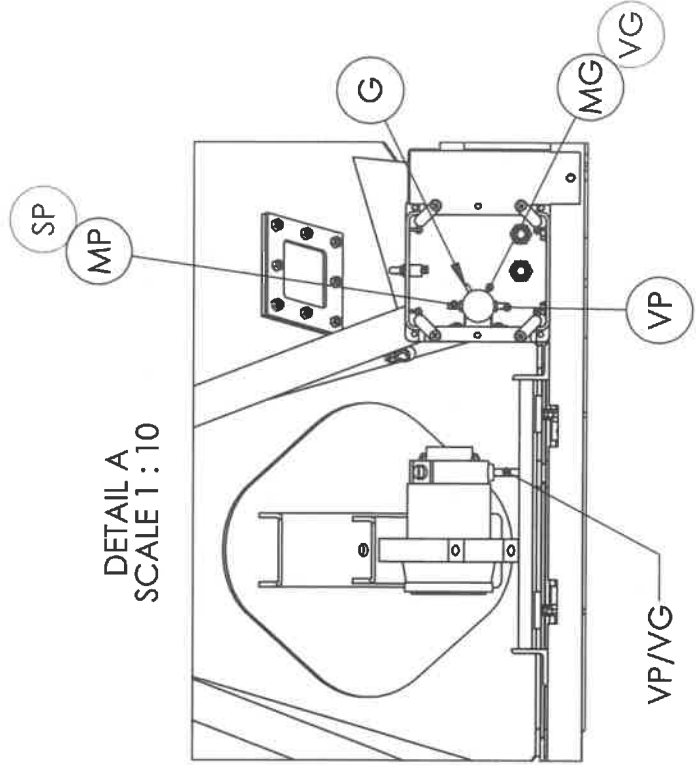
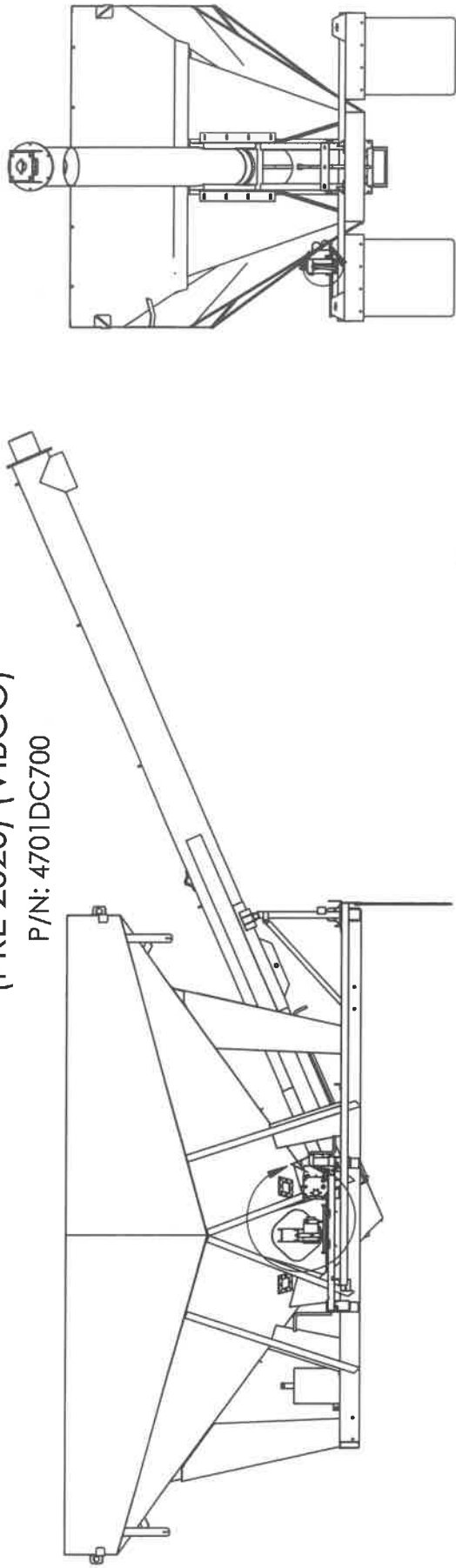

LETTER	DESCRIPTION
G	GROUND WIRE
SP	SWITCH POWER
MG	MAIN GROUND
MP	MAIN POWER
VP	VIBRATOR POWER
VG	VIBRATOR GROUND

1612 W/ DUAL VIBRATORS PART LIST

(PRE 2020) (VIBCO)

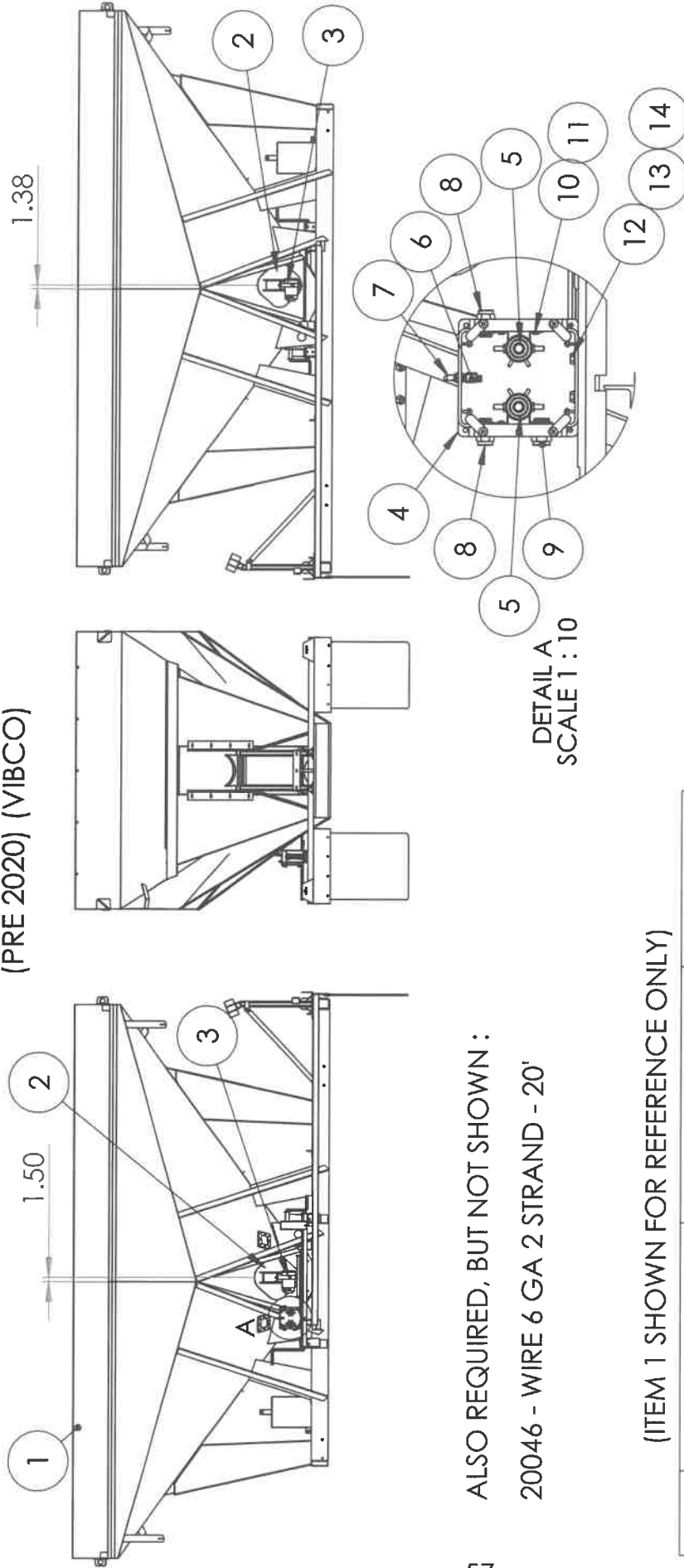

57 ALSO REQUIRED, BUT NOT SHOWN :
20046 - WIRE 6 GA 2 STRAND - 20'

(ITEM 1 SHOWN FOR REFERENCE ONLY)

ITEM NO.	PART NUMBER	DESCRIPTION	WITH BOX/QTY.
1	1612 tender	1612 MOUNTED WITH FENDERS	1
2	47007997	VIBRATOR PAD	2
3	DC-700	VIBRATOR	2
4	18000047	MEDIUM ELECTRICAL BOX	1
5	77002	4-PORT SOLENOID	2
6	18000049	SELECTRA SWITCH SS206A-BG	1
7	18000046	SELECTRA SWITCH SS206A-BG	1

ITEM NO.	PART NUMBER	DESCRIPTION	WITH BOX/QTY.
8	18000041	1/2 CGB CG5050	2
9	18000048	CORD GRIP CG5050S	1
10	18000050	BOLT AH SS 1/4 X 3/4	4
11	18569200	NUT 1/4 NYLOCK SS	4
12	18026822	BOLT, HEX HD 3/8 X 1 NC SS	2
13	18991200	WASHER FLAT 3/8 SS	2
14	18987900	NUT SER FLG SS 3/8	2

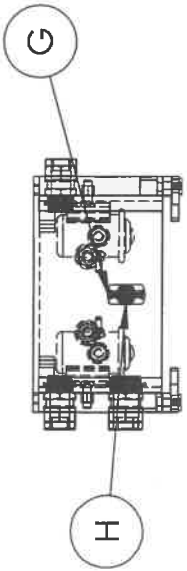

X - CONNECTION POINT
 PG - POWER GROUND
 PL - POWER LIVE

CONNECTION	END #1	END #2
A-A	5/16 TERM. HEAT SHRINK	5/16 TERM. HEAT SHRINK
B-B	3/16 TERM. HEAT SHRINK	3/16 TERM. HEAT SHRINK
C-C	3/16 TERM. HEAT SHRINK	3/16 TERM. HEAT SHRINK
D-D	5/16 TERM. HEAT SHRINK	5/16 TERM. HEAT SHRINK
E-E	5/16 TERM. HEAT SHRINK	VIBRATOR (P) - NEAR
F-F	3/16 TERM. HEAT SHRINK	VIBRATOR (G) - NEAR
G-G	5/16 TERM. HEAT SHRINK	3/16 TERM. HEAT SHRINK
H-H	3/16 TERM. HEAT SHRINK	3/16 TERM. HEAT SHRINK
I-I	5/16 TERM. HEAT SHRINK	BUTT CONNECTOR - (P)
	(2 CORD WIRE TO LINK VIBRATOR FAR)	
J-J	3/16 TERM. HEAT SHRINK	BUTT CONNECTOR - (G)
	(2 CORD WIRE TO LINK VIBRATOR FAR)	
PL	4GA COPPER LAG -5/16	STRIPPED
PG	4GA SILVER TERM - 3/16	STRIPPED

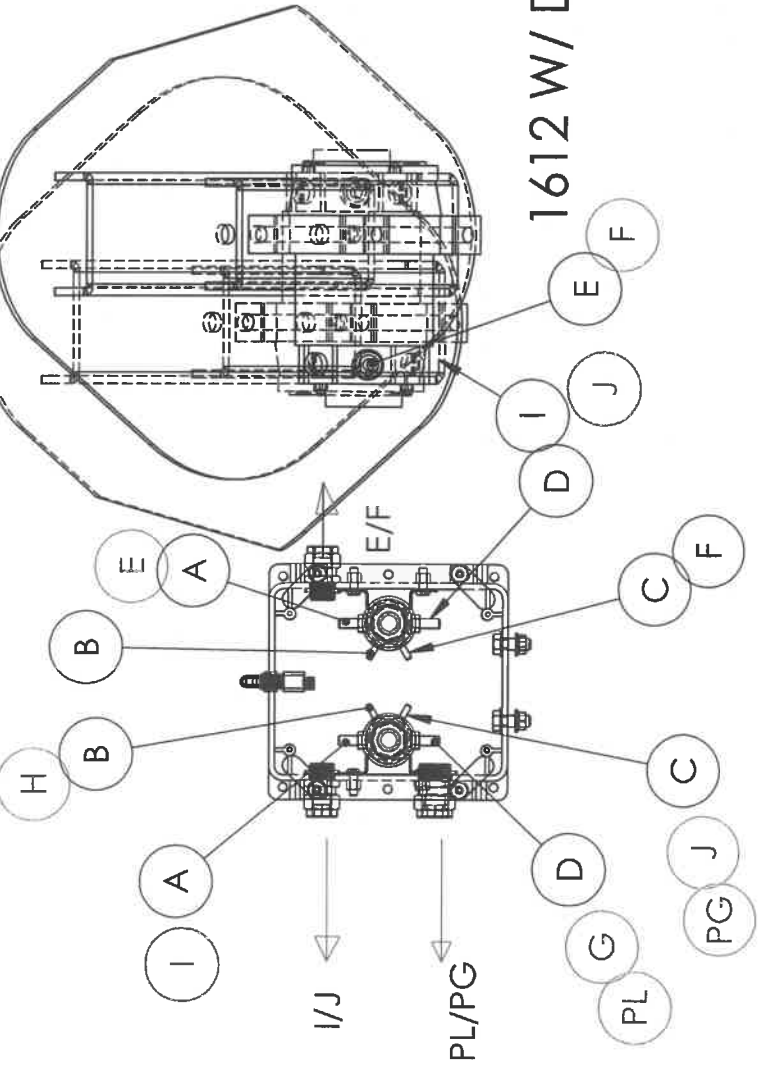

1612 W/ DUAL VIBRATORS WIRING DIAGRAM (PRE 2020)(VIBCO)

NOTE:

CONNECTIONS A-A THRU J-J USE A TOTAL OF 3' OF 14 GA WIRE (P/N: 6062)

A TOTAL OF 4 FT OF 2 CORD WIRE IS REQUIRED TO LINK FAR VIBRATOR

TWO SECTIONS OF HEAT SHRINK ARE TO BE APPLIED OVER THE BUTT CONNECTIONS

CONNECTIONS PL/PG USE A TOTAL OF 6' OF POWER CORD (PN: 20046)

MARTIN ENGINEERING VIBRATORS
JUNE 2020 & NEWER
SINGLE FRONT MOUNT
PN: 70895

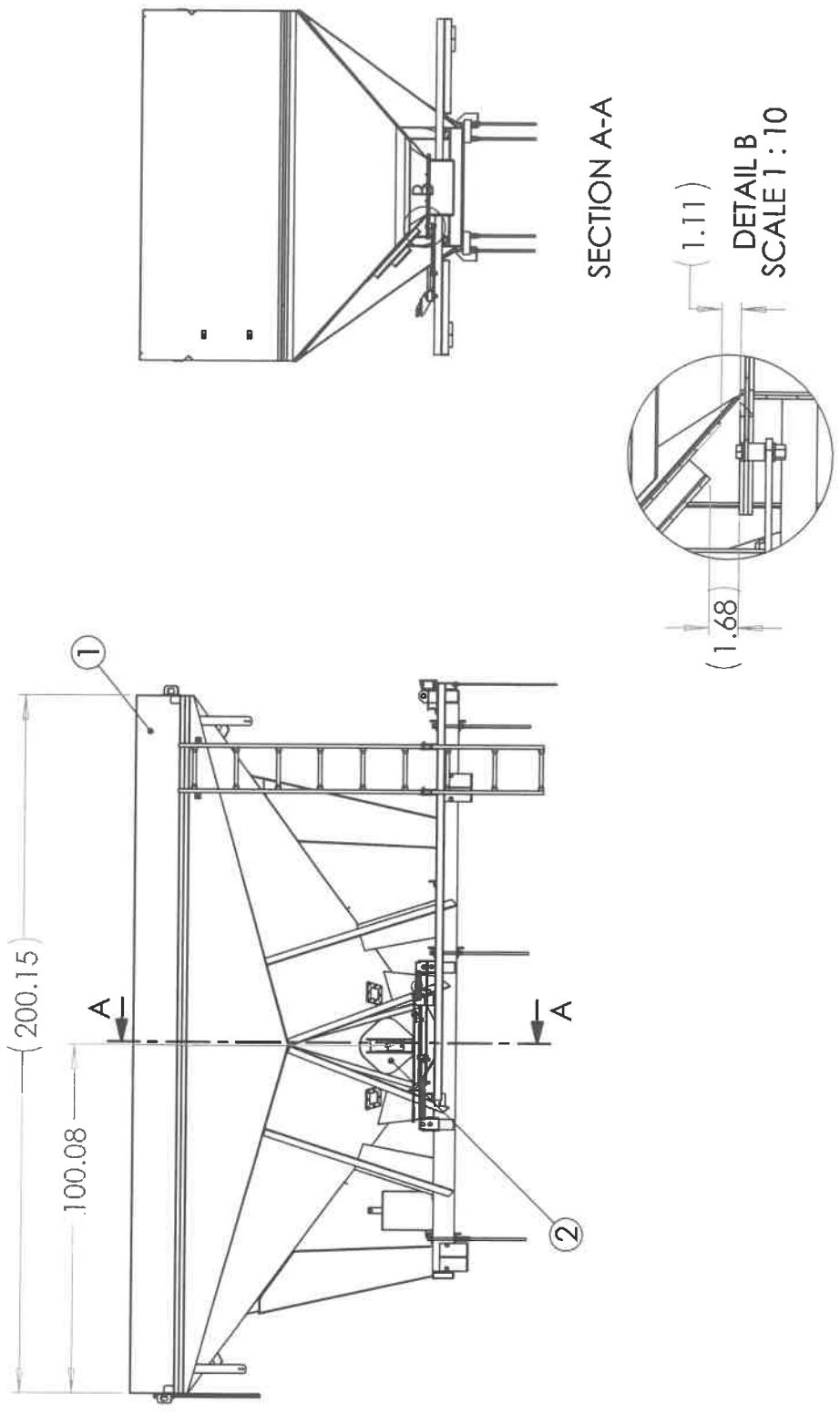

**MARTIN ENGINEERING VIBRATORS
 JUNE 2020 & NEWER
 SINGLE FRONT MOUNT
 PN: 70895**

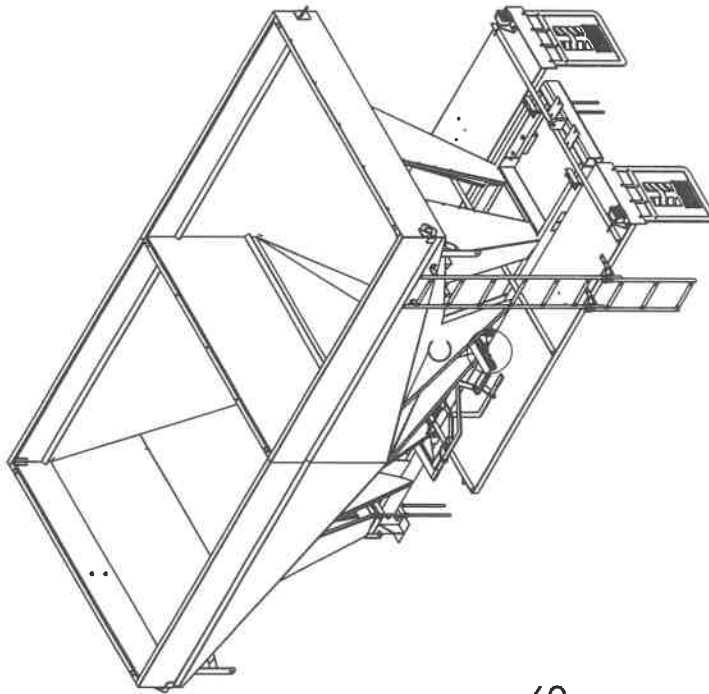

(ITEM 1 SHOWN FOR REFERENCE ONLY)

ITEM NO.	PART NUMBER	DESCRIPTION	QTY.
1	1612	1612 BODY	1
2	47007997	VIBRATOR MOUNT	1
3	MDCV12-700-MM-96-06	VIBRATOR	1
4	CG-100451	SWITCH (INCLUDED WITH VIBRATOR)	1
5	76737	VIBRATOR SWITCH PLATE	1
6	18097540	BOLT, HEX CAP 1/2-13 X 4 1/2 LG GRADE 8 ZC	2
7	18851400	WASHER FLAT 1/2 SAE ZC	2
8	18457400	NUT, NYLOCK 1/2-13 GRADE 8 ZC	2
9	18704218	SCREW MACH RD PH SS 8-32 X 3/4 LG	4
10	18474201	NUT HX NYLOCK #8-32 SS	4
11	18026422	BOLT CAP SS 5/16 X 1	2
12	18476351	NUT HX SS 5/16 SELF LOCK	2
13	195569-86	CORD EXTENSION 86" (INCLUDED W/ VIBRATOR)	1
14	735320	12GA/2 TRAILER WIRE	1

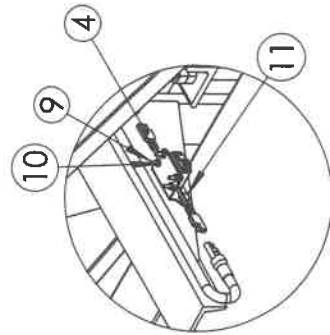

DETAIL C
 SCALE 1 : 10

ALSO REQUIRED BUT NOT SHOWN
 32504 - VINYL INSULATED RING - QTY 1
 38262 - STEP SOWN BUTT CONNECTOR - QTY 1

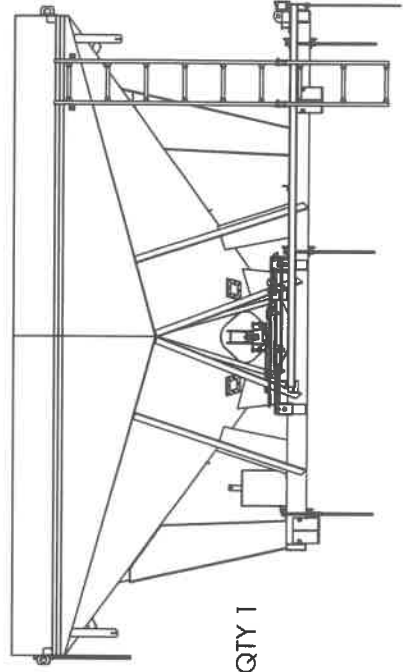

**MARTIN ENGINEERING VIBRATORS
 JUNE 2020 & NEWER
 SINGLE FRONT MOUNT
 PN: 70895**

TENDER W/ VIBRATOR

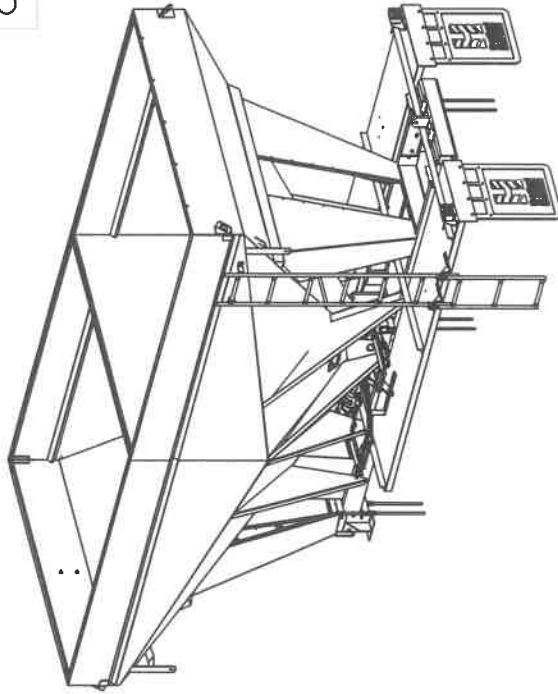

REPLACEMENT PART
 CG-100454 - FUSE 20 AMP

VIBRATOR ONLY

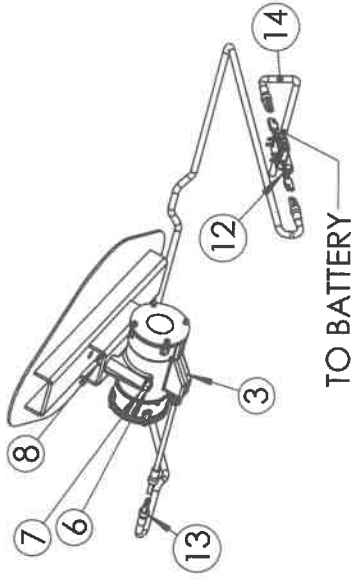

1. CABLE 13 COMES PRE ASSEMBLED TO VIBRATOR
2. ATTACH P/N 38262 (STEP DOWN BUTT CONNECTOR) TO THE END OF CONNECTOR
3. INSERT CUT TO LENGTH WIRE (P/N:735320 INTO THE OPEN END OF THE BUTT CONNECTOR AND SEAL
4. SEND P/N: 32504 (VINYL INSULATED RING) LOOSE

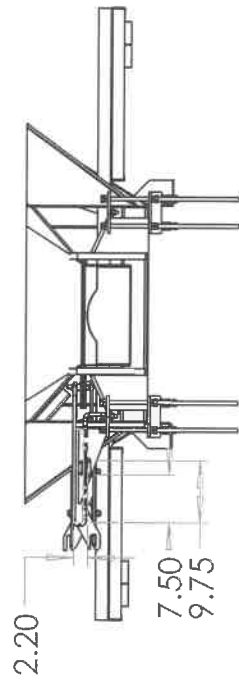

SECTION D-D
 SCALE 1 : 30

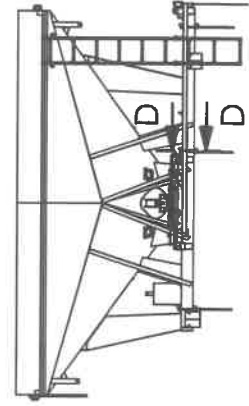

MARTIN ENGINEERING VIBRATORS
JUNE 2020 & NEWER

P/N: 70894

DUAL MOUNT
(DRIVER SIDE DETAIL)

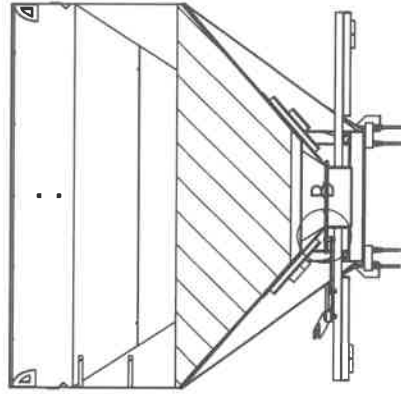
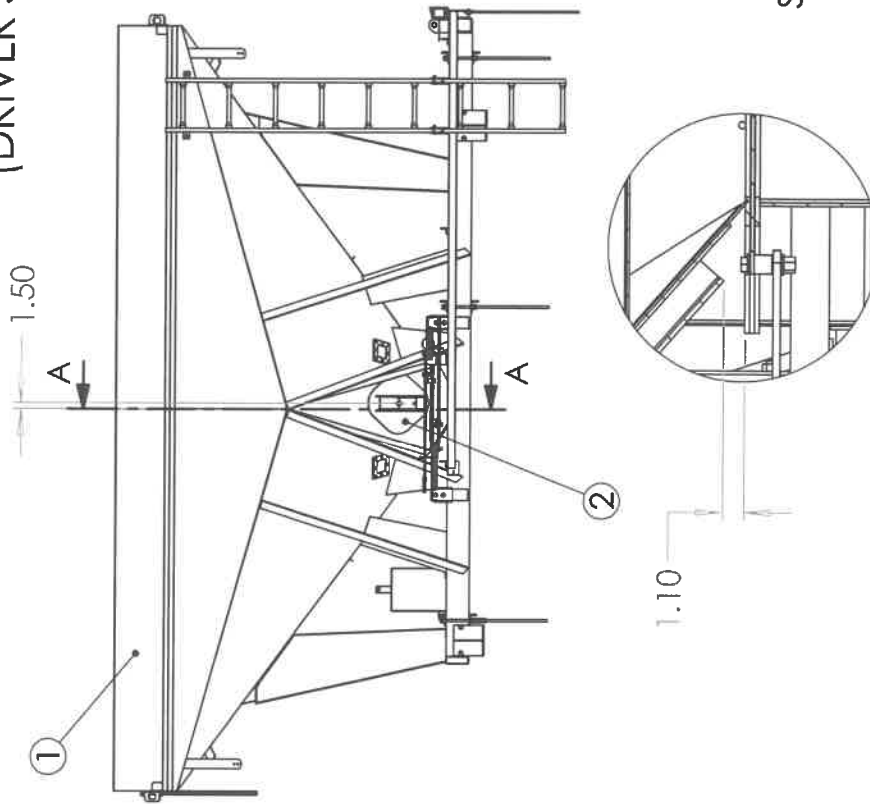

SECTION A-A

DRIVER SIDE WELD DETAIL

DETAIL B
SCALE 1 : 10

MARTIN ENGINEERING VIBRATORS
JUNE 2020 & NEWER

P/N: 70894

DUAL MOUNT
(PASSENGER SIDE WELD DETAIL)

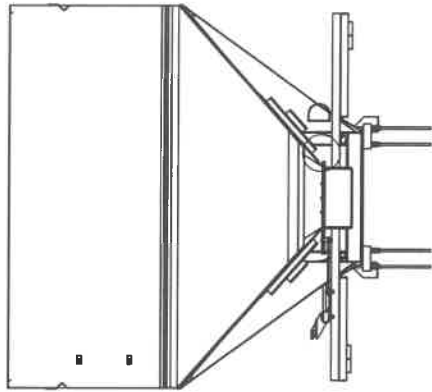
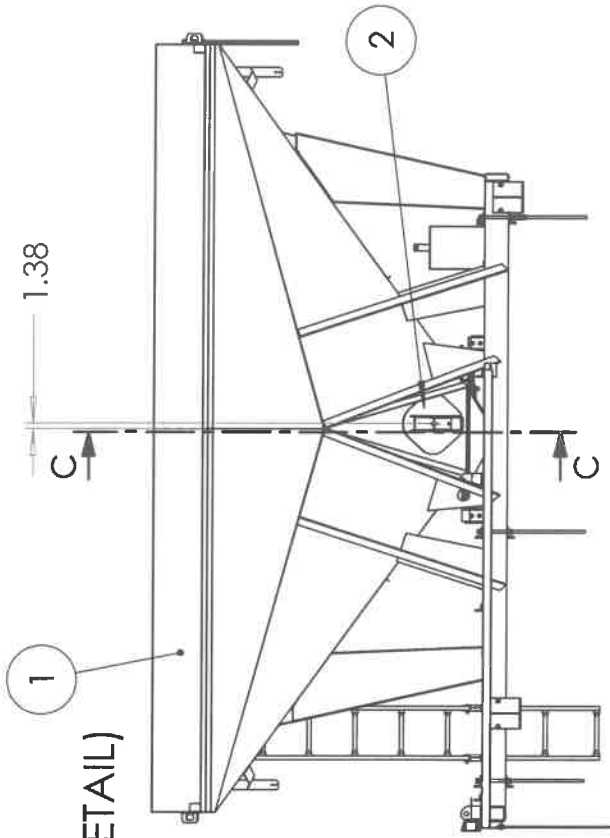

SECTION C-C

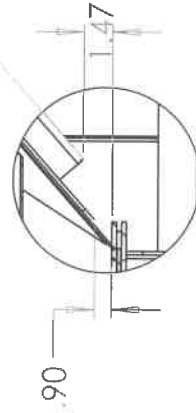

DETAIL D
SCALE 1 : 10

MARTIN ENGINEERING VIBRATORS
 JUNE 2020 & NEWER
 P/N: 70894
 DUAL MOUNT

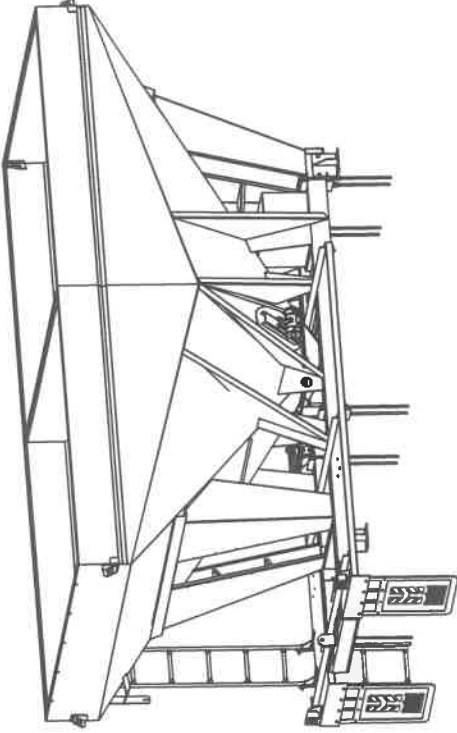
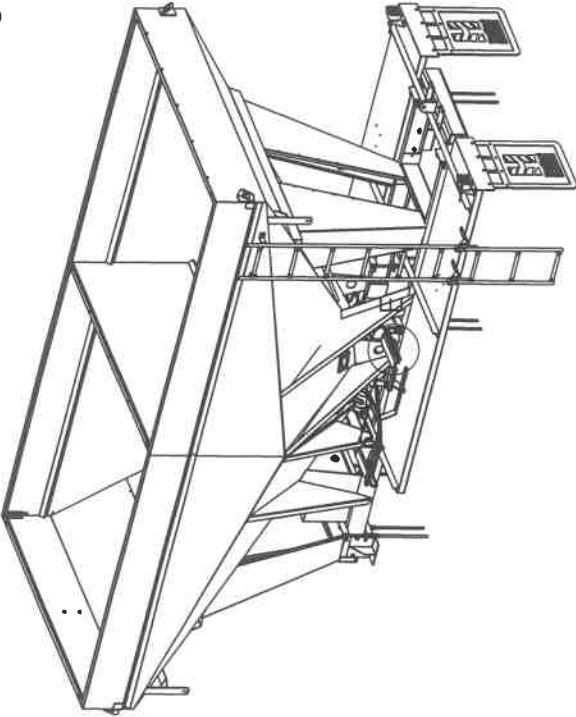

(ITEM 1 SHOWN FOR REFERENCE ONLY)

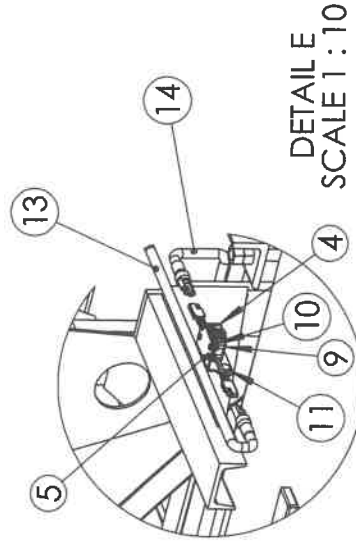

ITEM NO.	PART NUMBER	DESCRIPTION	QTY.
1	1612	1612 BODY	1
2	70892	VIBRATOR MOUNT	2
3	MDCV12-700-MM-96-06	VIBRATOR	2
4	CG-100451	SWITCH (INCLUDED WITH VIBRATOR)	2
5	76737	VIBRATOR SWITCH PLATE	2
6	18097540	BOLT, HEX CAP 1/2-13 X 4 1/2 LG GRADE 8 ZC	4
7	18851400	WASHER FLAT 1/2 SAE ZC	4
8	18457400	NUT, NYLOCK 1/2-13 GRADE 8 ZC	4
9	18704218	SCREW MACH RD PH SS 8-32 X 3/4 LG	8
10	18474201	NUT HX NYLOCK #8-32 SS	8
11	18026422	BOLT CAP SS 5/16 X 1	4
12	18476351	NUT HX SS 5/16 SELF LOCK	4
13	195569-86	CORD EXTENSION 86" (INCLUDED W/ VIBRATOR)	1
14	735320	12GA/2 TRAILER WIRE	1
15	195569-86	CORD EXTENSION 86" (INCLUDED W/ VIBRATOR)	1
16	735320	12GA/2 TRAILER WIRE	1

ALSO REQUIRED BUT NOT SHOWN
 32504 - VINYL INSULATED RINGS - QTY 2
 38262 - STEP DOWN BUTT CONNECTORS - QTY 2

MARTIN ENGINEERING VIBRATORS
 JUNE 2020 & NEWER
 P/N: 70894
 DUAL MOUNT

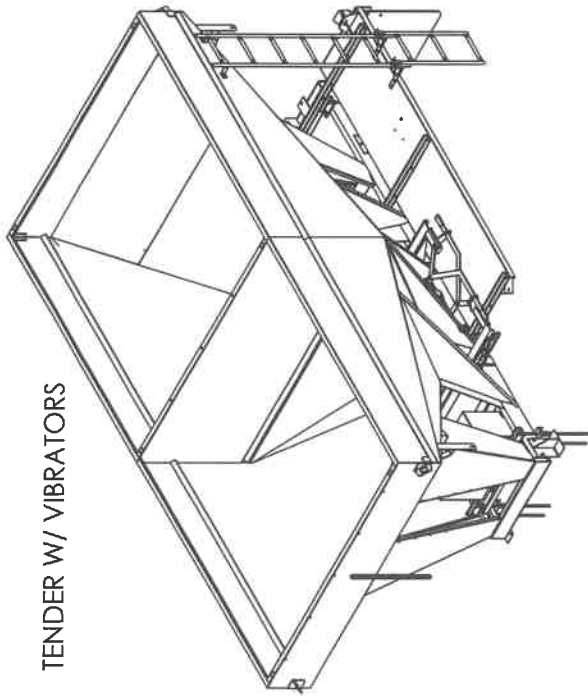

TENDER W/ VIBRATORS

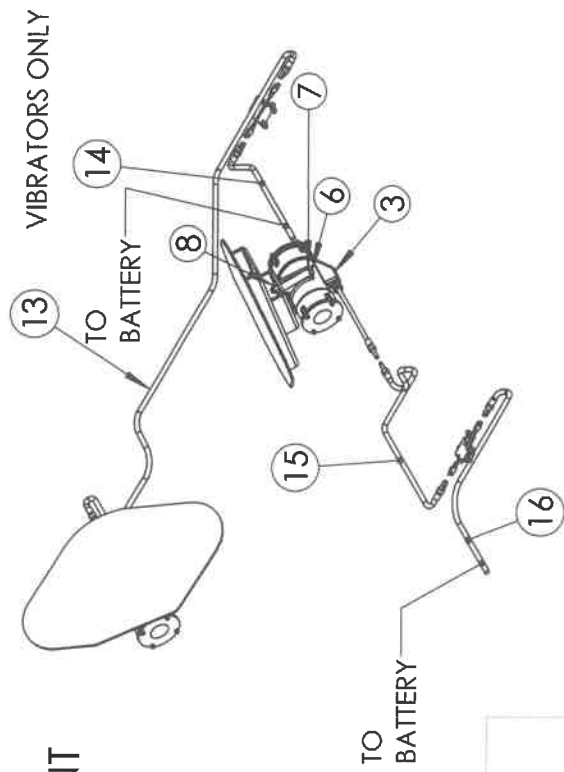

VIBRATORS ONLY

REPLACEMENT PARTS:
 CG-100454 - FUSE 20 AMP

1. CABLES 13 & 15 COME PREASSEMBLE TO VIBRATOR
2. ATTACH P/N 38262 (STEP DOWN BUTT CONNECTOR) TO THE CONNECTOR
3. INSERT CUT TO LENGTH WIRE (P/N: 735320) INTO THE OPEN END OF THE BUTT CONNECTOR AND SEAL
4. REPEAT FOR OTHER VIBRATOR
5. SEND P/N: 32504 (VINYL INSULATED RING) LOOSE

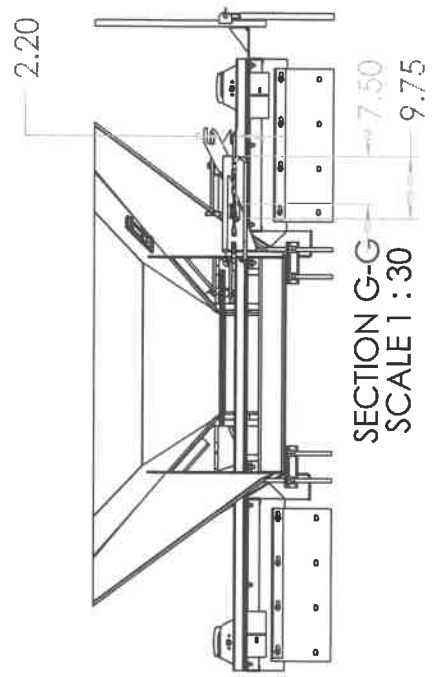

SECTION G-G
 SCALE 1 : 30

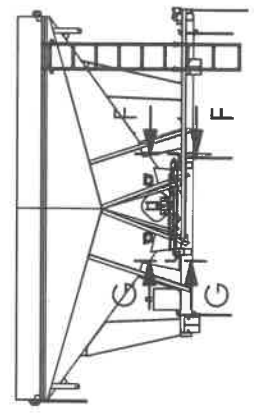

SECTION F-F
 SCALE 1 : 30

AUGER WARNING SYSTEM

PART #: 70660

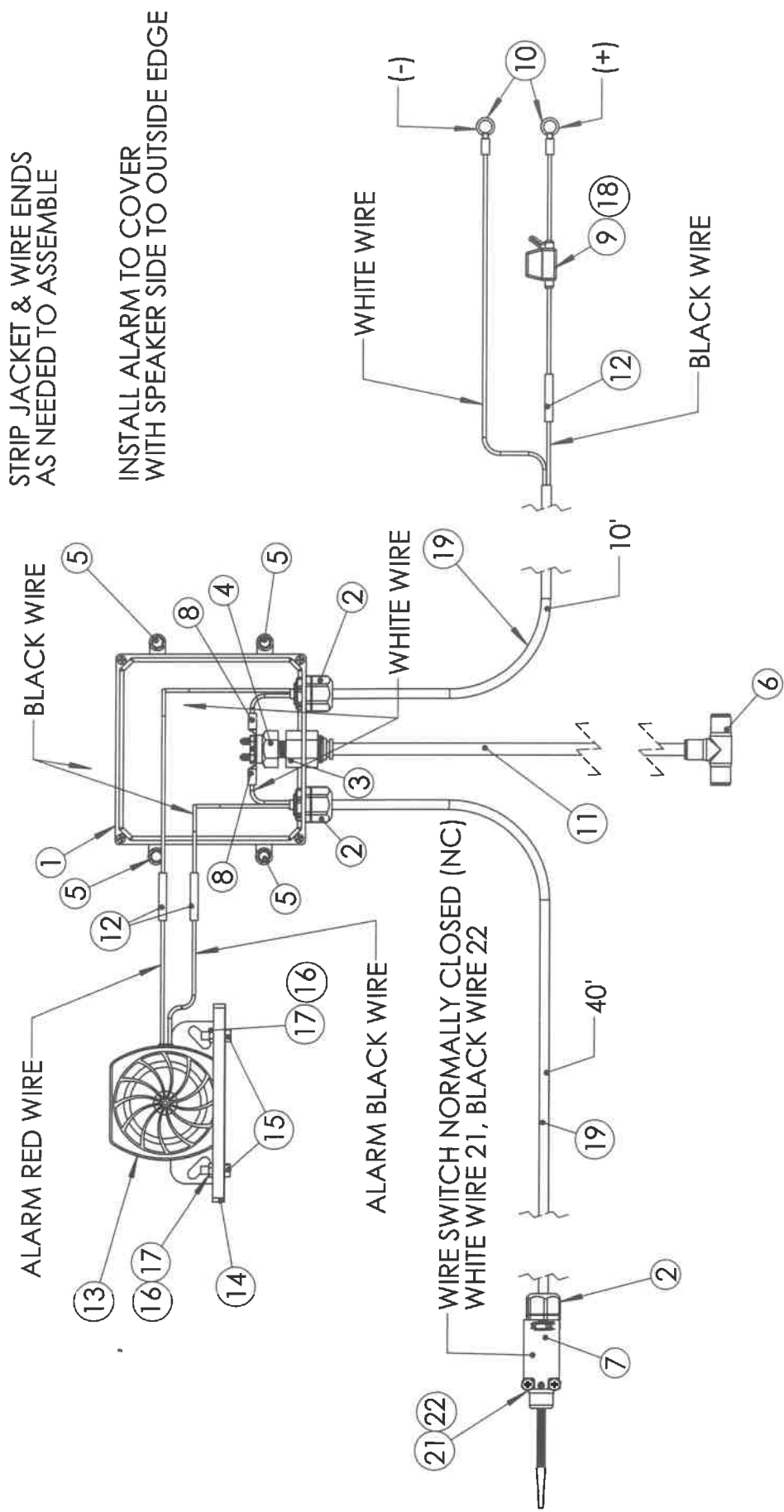

AUGER WARNING SYSTEM

PART #: 70660

ITEM NO.	PART NUMBER	DESCRIPTION	QTY.
1	70875	ALARM BOX	1
2	70878	CORDGRIP	3
3	70877	FEMALE BULKHEAD CONNECTOR WITH NUT	1
4	70876	STOP LIGHT SWITCH	1
5	70879	1/4" X 1" SELF TAPPING SCREW, SS, DRILL TIP	4
6	70880	UNION TEE, 3/8	1
7	70881	LIMIT SWITCH	1
8	70656	RING TERMINAL, HEAT SHRINK, 16-14 GA AND #10 SCREW SIZE	2
9	70882	IN LINE FUSE HOLDER	1
10	70883	RING TERMINAL, HEAT SHRINK, 16-14 GA AND 3/8" SCREW SIZE	2
11	70884	AIR BRAKE TUBING	8'
12	70886	SPLICE CONNECTOR, 16-14 GA, HEAT SHRINK	3
13	70887	ALARM	1
14	70875-2	ALARM BOX COVER (INCLUDED W/ ALARM BOX)	1
15	18055718	BOLT HX 1/4 X 3/4	2
16	18881001	WASHER FLAT 1/4 SS	2
17	18569200	NUT 1/4 NYLOCK SS	2
18	70888	FUSE, 7.5A	1
19	70885	PORTABLE CORD	50'
20	70658	ADHEASIVE BACKED CABLE TIE HOLDER, OUTDOOR	12
21	71043	NUT, NYLOCK, 10-24, SS	2
22	71044	SCREW, PAN HEAD, 10-24 X 1-3/4", SS	2
23	70659	CABLE TIE, 7-1/2" LONG, OUTDOOR	12

1612 TENDER MOUNTING LOCATION

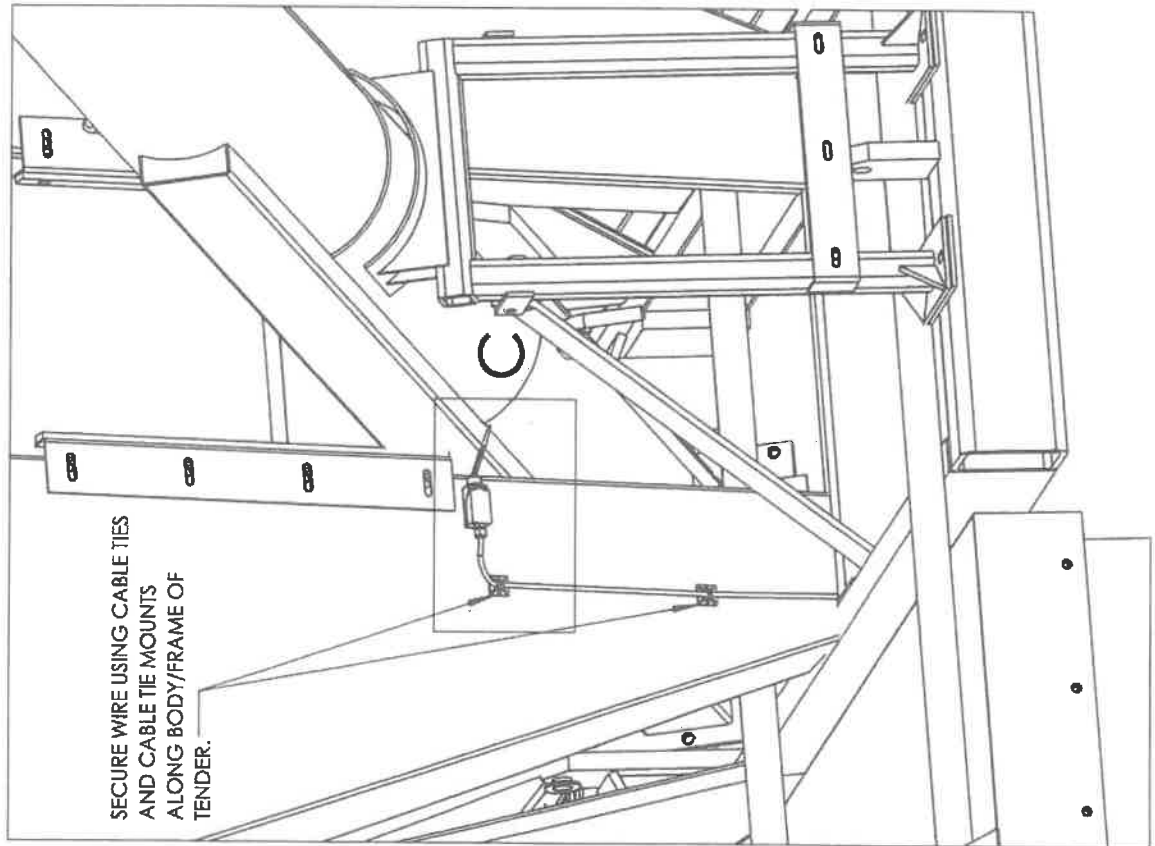

LOCATE SWITCH AS SHOWN ON REAR GUSSET SO THAT TOGGLE ARM IS TRIGGERED WHEN AUGER IS SEATED IN CRADLE. AN AUDIBLE CLICK CAN BE HEARD WHEN SWITCH IS TRIGGERED.

MATCH DRILL HOLES FOR SWITCH AND ATTACH USING ITEMS 21-22.

DETAIL C

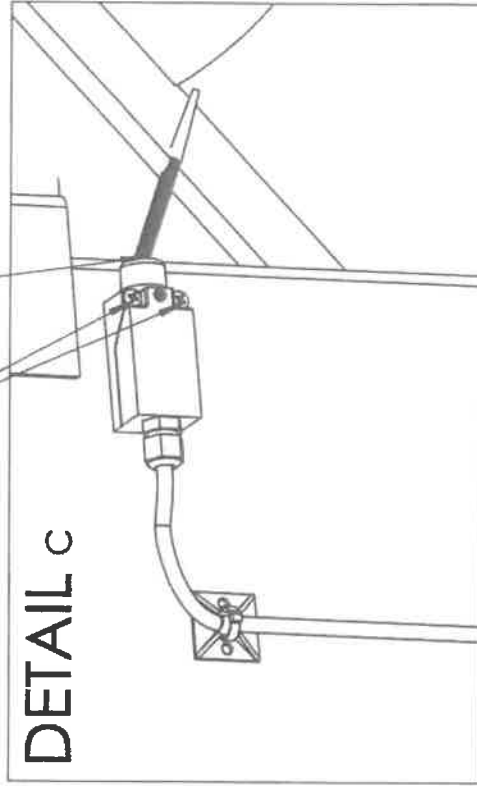

OPTIONAL BOLT ON POKE HOLE & FLUSH TUBE P/N: 71850

ITEM NO.	PART NUMBER	DESCRIPTION	QTY.
1	71849	POKE HOLE/FLUSH TUBE WELDT	1
2	200A	BANJO 2" CAM LEVER COUPLING, MALE ADAPTER FEMALE THREADS	1
3	200172	2" FEMALE COUPLER CAP	1

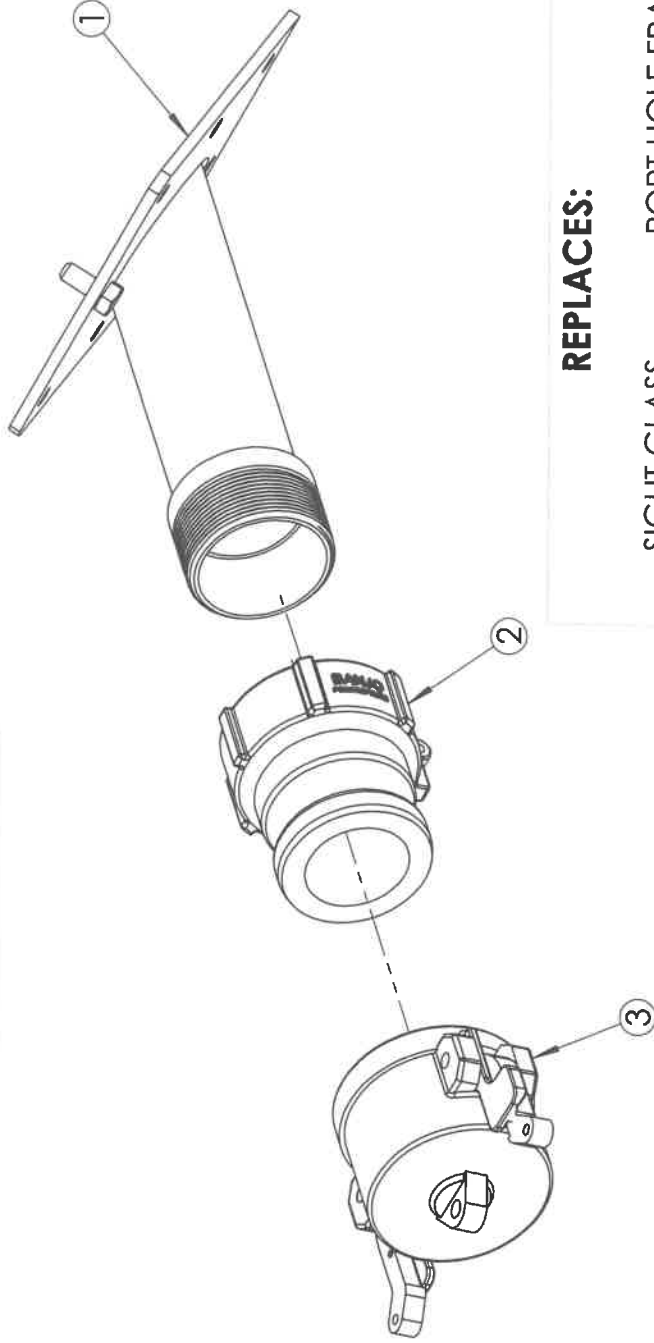

REPLACES:

SIGHT GLASS
P/N: 76608

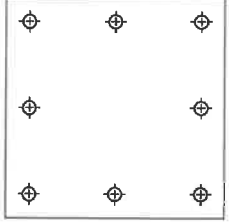

PORT HOLE FRAME
P/N: 76609

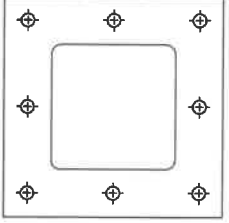

ORDER 1 PER WINDOW TO BE REPLACED

SECURE USING THE HARDWARE REMOVED FROM WINDOWS

(18026422 - BOLT CAP SS 5/16 X 1 - QTY 7 (8 WILL BE REMOVED))
 (18476351 - NUT HX SS 5/16 SELF LOCK QTY 8)

