



Heartland
AG SYSTEMS

Heartland Agriculture, LLC

NITROMASTER
TOOLBAR
8500 SERIES
16 1/2' CENTER SECTION

OWNERS MANUAL
ASSEMBLY INSTRUCTIONS
AND PARTS LIST
OM-8500

HEARTLAND AG SYSTEMS
1180 STATE HWY 7 EAST
HUTCHINSON, MN. 55350
(320) 587-4030

ISSUE
JANUARY 2024

WARRANTY REGISTRATION

TO THE DEALER:

Inspect the implement thoroughly after assembly to be certain it is functioning properly before delivering it to the customer. Check off each item as it is found satisfactory or after proper adjust is made.

PRE -DELIVERY CHECKLIST

- _____ 1. All hardware properly tightened.
- _____ 2. Lubrication of grease fittings.
- _____ 3. All decals properly located and readable.
- _____ 4. Other adjustments, "level operation", "drawbar height", etc.
- _____ 5. Proper tongue weight after all options are mounted. Adjustments made if required.
- _____ 6. Overall condition. Touch-up paint any scratches. Clean and polish
- _____ 7. Operator's manual.

Seller Information	
Date set-up	_____
Signature	_____
Dealer name	_____
Address	_____
City, state, zip	_____
Phone	_____

Review the operator's manual with the customer. Explain the following:

- _____ 1. Safe operation and service
- _____ 2. Correct machine installation and operation.
- _____ 3. Correct and periodic lubrication and maintenance.
- _____ 4. Daily and periodic inspection.
- _____ 5. Troubleshooting.
- _____ 6. Storing machine.
- _____ 7. Heartland AG Systems parts and service
- _____ 8. Have the customer write the machine model and serial number in the space provided in the manual introduction
- _____ 9. Give the customer the operator's manual and encourage the customer to read the manual carefully.

Customer Information	
Date delivered	_____
Customer name	_____
Customer address	_____
Signature	_____
Model number	_____
Serial number	_____

PLEASE FILL OUT THIS SHEET AND RETURN TO HEARTLAND AG SYSTEMS

1180 State Highway 7 East Hutchinson, MN 55350

www.heartlandag.com | Heartland Agriculture, LLC dba Heartland AG Systems

CONTENTS

Dealer Checklist (Fill out and return)	
Table of Contents	1
To the Owner	2
Warranty	W1-8
Introduction	5
Safety	6
Decals	6A
Assembly Procedure	7 to 10
Coulters and Disk Sealer Mounting Info	11
Toolbar Illustration	12
Toolbar Parts List	13
Primary & Secondary Wing Assembly	14
Wings Parts List	15
Hubs Illustration	16
—	17
Hydraulic Plumbing Schematics	18 to 21
Hydraulic Cylinders And Parts	22
Stagger Bracket Assembly	23
Field Hitch Assembly	24
Spring Bundle Assembly (Yr 2000 to Present)	25
<hr/>	
2014 HI-TRIP Bundle Ass'y (Edge-Bent Shank)	26
2014 HI-TRIP Bundle (set up profile)	27
AG37 Coulters Assembly, Generation Two	28 & 29
AG38 Coulters Assembly, Generation Two	30 & 31
AG37 Coulters Assembly, Generation Three	32 & 33
AG38 Coulters Assembly, Generation Three	34 & 35
Coulters Service Procedure	36
Disc Cover Sealer, 13 inch W/bolt-on-hub	37
Disc Cover Sealer, 18 Inch W/bolt-on-hub	38
Disc Cover Sealer Assembly Instructions	39
Shank Location Illustrations,	40 to 46
NH3 Distribution Stands and Brackets	47
NH3 Quick Coupler (swing arm style) 2015	47A
NH3 Plumbing Schematic Illustration	48
NH3 Break-Away coupling device Installation, Operation, and Maintenance.	48A
Safety Light Kit	49
Disk Cover Sealer W/Floating Arms	50 & 51
Montag Cart Mount and Field Hitch	52 & 53

TO THE OWNER

This manual has been prepared to assist you in the assembly of your new equipment and contains information pertaining to safety, operating information and all its parts.

Our personnel in sales and service are always available to assist you when questions arise concerning the assembly and operation of your machine.

When ordering parts, please refer to part numbers and descriptions as listed throughout this book. All parts and whole goods will be shipped FOB Hutchinson, Minnesota. Always check merchandise immediately upon receipt for damage or shortage. Note any discrepancy on the carrier's bill of lading and notify Heartland AG Systems within 10 days.

Any returned goods will be subject to a 20 percent restocking charge.

Heartland AG Systems reserves the right to make improvements and modifications on equipment without obligation to change previously built equipment. All prices are subject to change without notice.

Warranty Policies and Terms

The Heartland Agriculture, LLC warranty is a limited warranty that is provided to the retail purchaser in return for consideration paid as part of the purchase price for a product. The selling dealer must review the warranty coverage with the retail purchaser and obtain a signature on the Operators Manual for warranty verification.

The warranty described here is for Heartland Agriculture, LLC doing business as Heartland AG Systems and its product line Heartland AG Systems Equipment sold and registered in the United States and Canada and normally operated in the United States and Canada.

Warranty Period

The warranty period for all coverage begins at the time that any person, dealer or agent first places the unit into service. At the latest, a unit is placed into service when purchased or delivered to a purchaser.

What's Covered

If a defect in material or workmanship is found in a unit and reported during the Warranty period, Heartland AG Systems will pay parts and labor costs to repair the defects if the services are performed by an authorized Heartland AG Systems dealer. If parts are needed during the repair, Heartland AG Systems will, at its option, use genuine Heartland AG Systems, or remanufactured parts.

Heartland AG Systems provides no warranty, express or implied, for a component or other item that is separately warranted to the purchaser by its manufacturer, such as tires. Check with your local dealer for these details.

Exclusive Remedy

The remedy of repairing a defect in material or workmanship at a Heartland AG Systems dealership under the terms of this warranty is the purchaser's exclusive remedy and is in lieu of any other remedy otherwise available.

No Modification or Extension of Warranty

The Heartland AG Systems Warranty is limited to the written terms in the warranty statement. Heartland AG Systems does not authorize any person, dealer, or agent to change or extend the terms of this warranty in any manner. Any assistance to the purchaser in the repair or operation of any Heartland AG Systems product outside the terms or limitations or exclusions of this warranty will not constitute a waiver of the terms, limitations or exclusions of this warranty, nor will such assistance extend or re-establish the warranty.

The warranty is void if the unit is used in an application for which it is not designed or the unit has been scrapped, salvaged, stolen, junked or totaled.

Limitations and Exclusions

The Heartland AG Systems warranty gives you specific legal rights and you may also have other rights, which vary from state to state. This section contains the entire Heartland AG Systems warranty. Heartland AG Systems makes no other representations or warranties, expressed or implied, and specifically excludes the implied warranties of merchantability and fitness for particular purpose. Heartland AG Systems will not be liable for incidental or consequential damages resulting from a breach of the written warranty or any implied warranty.

- These limitations and exclusions may not be allowed by some states or provinces and shall not apply to the extent such limitations or exclusions are not allowed by applicable state/provincial law.

Owner's Responsibility

The Heartland AG Systems Warranty remains in effect during the warranty period if the owner performs the required maintenance at the recommended intervals outlined in the product's operator's manual and the unit is operated within its rated capacity. Genuine Heartland AG Systems service parts or Heartland AG Systems approved service parts that meet Heartland AG Systems specifications must be used for maintenance and repairs.

What Is Not Covered

- Replacement of non-defective wear items expected to be replaced during the warranty period, including, but not limited to: lights, fuses, belts, drive sprockets and chains, hose, soil engaging tools, spray tips, fertilizer deflectors, spinner blades and accessories or items replaced due to customer demand.
- Normal maintenance parts and service, including, but not limited to lubrication, coolants, and filters.
- All travel costs associated with hauling or towing a customer's machine to and from a repair center related to any warranty repair unless specifically covered by a program or policy.
- Repairs arising from any unauthorized modification to the product.
- Repairs arising from service performed by agents not approved by Heartland AG Systems.
- Repairs arising from storage deterioration, failure to maintain the equipment, improper use of the equipment, collision or other accident, vandalism, or other casualty, or operation beyond the rated capacity or specifications.
- Repairs arising from abuse or neglect including, but not limited to operation without adequate lubricants or coolant, over-speeding, contaminated fluids, improper storage, starting, warm-up, or shutdown practices.
- Failure of the machine, its implements or attachments caused by improper field application or overloading.
- Premiums charged for over-time labor costs.
- Economic loss, including lost profits, crop loss, equipment rental or other expenses.
- Cost associated with cleaning of machine in preparation for service.
- Loss or damage during shipment.

- Cost of initial setup or installation of any optional equipment or attachments to a unit.
- Items used for repairs include, but are not limited to: solvents, cleaners, anti-seize lubricants, oil-dry, shop towels, shop supplies, special tools, etc.
- Included, but not limited to are checkups, adjustments, and shimming, tune-ups, spread pattern checks, etc.
- Unauthorized modification or field fixes.
- All costs of special tools or shop supplies incurred with repairs.
- Claims for stolen equipment or parts.
- Claims for replacing a complete assembly when the repair is less than the replacement.
- Claims involving the inspection or reconditioning of units.
- Shop comebacks: any duplicate, repeat, or comeback repair resulting from improper diagnosis, testing, or poor service work.
- Cost of removing or installing Non-Heartland AG Systems optional equipment or attachments.

Base Warranty Coverage

- Base Warranty is the factory warranty provided to the customer at no additional cost for a specific period covering the complete machine.

• Liquid Applicators, except tires	1 Year
• Spreaders and Tenders, except tires	1 Year
• Nh3 Wagons, except tires	1 Year
• Bumper Hitches	1 Year
• Disc Covers	1 Year
• Parts	90 Days
• Tandem Wagons (except tires and main frame)	1 year
o Tandem Wagon main frame	5 Years
• Nitromaster Toolbars shall carry the following pro-rated warranty:	
o Year one, all components except tires	100%
o Year two, center section and wings	80%
o Year three, center section and wings	50%
o Year four, center section and wings	25%
o Year five, center section and wings	10%

Tires

Tires installed on all Heartland AG Systems Equipment are warranted and serviced by their manufacturer's service outlets. Some manufacturers have separate service outlets for off road agricultural and construction equipment. Service is available by contacting the tire manufacturer's local representative.

Warranty Registration

All machinery items, which are invoiced by Heartland AG Systems on separate receivables, must be registered for warranty. The warranty period for all coverage begins at the time that any person, dealer, or agent first places the unit into service. New machine warranty coverage begins when the machine is registered. Registration is accomplished when a properly completed Warranty Registration is received and processed by Heartland AG Systems.

Operator's Manual/Warranty Receipt Verification

The Heartland AG Systems New Equipment Limited Warranty for Agricultural Equipment statement must be filled out and signed by the customer indicating receipt and an understanding of the operator's manual and the warranty statement,

- The original form must be mailed to the address on the form.
- Make one copy for the Dealer. This copy must be retained by your dealership the same as any other legal document.
- Make a second copy for the customer.

Heartland AG Systems Responsibility

If a defect in material or workmanship is found in a product during its warranty period, Heartland AG Systems will pay parts and labor costs to repair the defect when the service is performed by an authorized Heartland AG Systems dealer or agent. If parts are needed during the repair, Heartland AG Systems will, at its option, use genuine Heartland AG Systems new or remanufactured parts. These responsibilities include, but are not limited to:

- Costs for repairs that are the result of defects in material and workmanship
- Payment to dealers per policy in a timely manner
- Service information to dealers
- Identify product deficiencies and take corrective action by field campaigns
- Make determination of premature wear
- Provide unit that is free of defects in material & workmanship

Dealer Responsibility

Heartland AG Systems dealers are responsible for providing prompt, courteous, and willing service to all Heartland AG Systems equipment owners. These responsibilities include but are not limited to:

- Equipment set-up and pre-delivery
- Sell the right product for the intended application
- Inspect the unit and initiate recovery action on any shipping damage and or shortages
- Instruct customer on proper use, maintenance, and safety features of machine
- Advise and explain warranty coverage to customer
- Diagnose the problem, repair the unit, and submit claims in accordance with the terms and conditions of the warranty claim policies
- Take responsibility for saying "NO" to customers on non-warranty failures
- Apply failure analysis to questionable repairs
- Complete product update campaigns
- Have properly trained technicians and adequate tools for the job
- Retain proper documentation of failure repaired

Owners Responsibility

The Heartland AG Systems warranty remains in effect during the stated warranty period if the owner performs the required maintenance at the recommended times as outlined in the products operator's manual. Genuine Heartland AG Systems or Heartland AG Systems approved service parts must be used for maintenance. Additionally, the owner will pay for all transportation or travel expenses related to any warranty repair.

These responsibilities include, but are not limited to:

- Perform maintenance as indicated in the operator's manual
- Use the unit in the correct application (non-abusive)
- Notify dealer of failures and have the machine available for repair in a timely manner
- Training operators
- Travel cost, towing charges, and service calls
- Normal wear items
- Machine damage (accidental)
- Adjustments for application
- Machine inspection (daily walk-around)

Warranty Eligibility

The dealer is responsible to determine that any Heartland AG Systems equipment is covered by Heartland AG Systems warranty before performing a repair and that the repair is a warrantable failure. Any dealer who is in doubt of the equipment's warranty eligibility may call Heartland AG Systems for verification.

Warranty Repairs Made by the Customer



Heartland Agriculture, LLC



If a Heartland AG Systems dealer determines that the customer is capable, and the customer requests permission to perform select(warranty)repairs on his product, the Heartland AG Systems dealer is authorized to grant this customer request. The servicing dealer should provide the parts to the customer upon request, and to assure that customer is properly instructed on how to perform the repairs correctly.

The servicing dealer is responsible and accountable for claim accuracy and validity; specifically, in areas such as the parts replaced date, and assurances that the parts are installed as instructed by Heartland AG Systems. The comments section of the claim should clearly state that the customer installed the parts. The claim reimbursement will be for parts and applicable handling only. No labor is allowed! All replacement parts must be held for possible recall.

Parts Shortages on Whole-Goods

Dealers may submit a claim for parts shortages discovered during pre-delivery or during final assembly at the dealer's location. All claims for shortages must be submitted 5 days from the original ship date from the plant and before the warranty start date.

Warranty Reimbursement Policies

Heartland AG Systems provides for warranty reimbursement due to defects in material or workmanship only. Warranty does not include restoring any machine or portion thereof, which has accumulated hours of operation, to factory new condition. This includes customer owned and used equipment.

Except for only a few items not available through Heartland AG Systems, all Heartland AG Systems manufactured equipment warranty repairs must be performed using only Heartland AG Systems genuine new or remanufactured parts and accessories. Installation of non-Heartland AG Systems parts does not qualify for warranty reimbursement and can void the machine's warranty.

Parts

It is fully expected that all claims be filed using part numbers from the applicable Heartland AG Systems equipment parts book whenever such part number exists. Heartland AG Systems shall reimburse the dealer at the dealer net price (cost) in effect on the parts replaced date.

Labor

Heartland AG Systems shall reimburse the dealer at 80% of the dealer's posted retail shop labor rate. The retail shop labor rate shall be subject to verification by Heartland AG Systems from copies of actual dealer invoices to customers.

Outside Charges

Specialized repair such as that done by a machine shop will be accepted as part of a warranty claim at actual cost. Explain the parts used and the service work performed in the description section of the claim and retain a copy of the receipt. Retain a copy of the invoice with the shop work order to support the claim. Outside repairs that exceed the cost of the same repair, if performed by the dealer, will be reimbursed at a lower rate.

Freight

Heartland AG Systems will pay the freight charges when a warranty recalled part is to be returned to Heartland AG Systems.

Travel

Travel will only be reimbursed when authorized by a field campaign.

Repairing or Replacing Parts and Components

When performing a warranty repair, a complete part or component should not be replaced under warranty if the repair can be accomplished at a lower cost. If the total cost of the repair including the cost of parts, labor, and/or outside labor or materials is less than 75% of the cost of the parts, the part must be repaired.

Filters and Lubricants

Replacement of lubricants and filters do not qualify for warranty reimbursement unless damage caused by a defect in material or workmanship results in contamination or sudden loss of fluid. Lack of maintenance, operator misuse, or neglect will not qualify for warranty reimbursement.

Claim Form Guidelines

Claims Must Have

1. Product identification number (PIN) or serial number. All characters of the PIN must be used on the warranty claim.
 - Claims for parts warranty must use the word "PARTS" for the PIN. An invoice that shows date of sale or date of installation must be supplied for all parts claims.
2. Model Number
3. Date of failure – Claims must be submitted within 30 days or repair.
4. Date of repair
5. Warranty start date. Date the unit warranty starts or date the parts were sold for parts warranty.
6. Description of the problem. Describe all problems pertinent to the claim.
Comments should be as precise as possible, attach a separate sheet if necessary, to describe the problem.
7. Description of the work performed. List each significant action of the repair.
8. Itemize labor. Provide a breakdown of labor for each significant repair action in the "Describe Work Performed" column.
9. Shop order numbers. The shop order number field is used for recording your shop work order number that is related to the claim. The shop order number field can also be used to record the parts invoice number when claiming a parts warranty.
10. Customer information. Customer information includes the customer name, city, state, county, and postal code. It must match the warranty registration.
11. Warranty claim total. The total of all reimbursement costs requested.
12. Dealer signature and date. All claims must be signed and dated by the distributor to be validated.

INTRODUCTION

Read this manual carefully. It will instruct you on how to operate and service your machine safely and correctly. Failure to do so could result in personal injury and/or equipment damage.

Right hand and left hand sides of the machine are determined by (standing behind the machine) facing in the direction the machine will travel when going forward.

SAFETY INFORMATION

DANGER: This message denotes the most serious specific potential hazard. This sign will have the color combination of RED and WHITE.

WARNING: This message denotes a specific potential hazard.

CAUTION: This message denotes a reminder of safety practices.

 **NOTE:** Indicates a special point of information.

***** Carefully read and follow all safety signs.
***** Reinstall safety signs that are damaged or missing.

Warranty is provided for customers who operate and maintain their equipment as described in this manual. Warranty registration is accomplished by the dealer completing and forwarding the WARRANTY REGISTRATION FORM along with a copy of the dealer's invoice to Heartland Ag Systems. It is in your best interest to insure that this has been done.

WARRANTY does not cover the following.

- 1. Cleaning, transporting, mailing and service call charges.
- 2. Depreciation or damage caused by normal wear, accidents, improper protection or improper use.

***** See complete WARRANTY for details

Record your machine model and serial number in the space provided. Your dealer needs this information to give you prompt, efficient service when you order parts.

MODEL NUMBER _____

SERIAL NUMBER _____

DATE PURCHASED _____

***** SAFETY INFORMATION CONTINUED *****

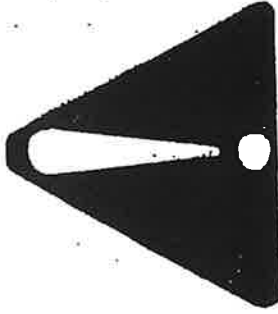

RECOGNIZE SAFETY INFORMATION

This is the safety-alert symbol. When you see this symbol on your machine or in this manual, be alert to the potential for personal injury. Follow recommended precautions and safe operating practices.

FOLLOW SAFETY INSTRUCTIONS

Carefully read all safety messages in this manual and on your machine safety signs. Keep safety signs in good condition. Replace missing or damaged safety signs.

Learn how to operate the machine and how to use controls properly. Do not let anyone operate without instructions.

Keep your machine in proper working condition. Unauthorized modification to the machine may impair the function and/or safety and affect machine life.

PROTECT CHILDREN AND BYSTANDERS

Before you back, **LOOK CAREFULLY** behind for children. Clear area of children, pets and bystanders.

TRANSPORT SAFETY

- * Always use safety chains during road transportation.
- * Check wheel nuts daily.
- * Use hydraulic cylinder transport lock-up during road transportation.
- * Maximum recommended road speed is 25 mph.
- * Clear machine of personnel and obstructions.

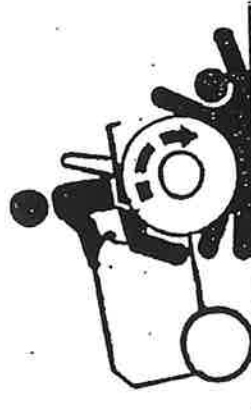
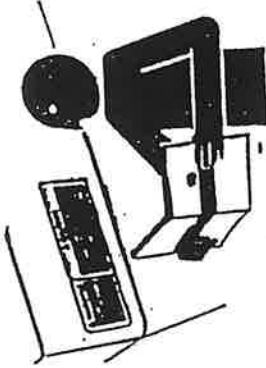

DECALS

PART # 699107



PART # 9744503



PART #699105

SAFETY INSTRUCTIONS

1. SAFETY DECAL PANELS must be in place and understood before operating this equipment.

2. Evacuate NH₃ from entire system, including ball valves, before servicing.

3. Replace outdated or damaged hoses and parts before each use.

4. Read and understand owner's manual before operating this equipment.

ENR105

PART #699102

HAZARDOUS CHEMICAL UNDER PRESSURE
Have emergency WATER available.

POINT
Irradiate vapor.

WEAR GOGGLES
and GLOVES to operate or service.

FAILURE TO FOLLOW THESE INSTRUCTIONS WILL RESULT IN SERIOUS INJURY OR DEATH

ENR102

PART #699101

DANGER

STAND CLEAR
Falling Wings May Cause Bodily Injury or Death

PART #699103

OPERATION INSTRUCTIONS

1. Wear GOGGLES and GLOVES. Have EMERGENCY WATER available.

TO DISCONNECT:

2. Refer to step one. Stand on levelled side. Close all valves; then open all valves. Close all valves, then open all bleed valves. **AWAY FROM FACE AND BODY.**

3. Do not connect or disconnect until flow from hoses has stopped.

4. Measure across threaded hose from top of:

TO CONNECT:

5. Measure across threaded hose from top of:

6. If coupler is not connected, insert upper wing into lower wing and push together until the wings are fully engaged. Insure proper connection.

DAILY MAINTENANCE

Failure to follow these instructions may result in personal injury, resulting in bodily harm.

1. Wear GOGGLES and GLOVES, if available.

2. Have EMERGENCY WATER available.

3. Close all bleed valves. Close all valves, then open all bleed valves. **DIRECT BLEED SPRAY AWAY FROM FACE AND BODY.**

4. Do not connect or disconnect until flow from bleeds has stopped.

5. Pull hose sharply to disconnect coupler.

6. Check proper closure of coupler check valves.

7. Replace coupler bodies if corroded.

8. Insure all connections are tight. Insure one expansion fill on coupler body-bleeds.

ENR103

PART #699104

BE CAREFUL

Clear Machine of Personnel And Obstructions Before Operating Hydraulic Wings!

PART # 699110

NITROMASTER SERIES

PART# 699100

WARNING

Stand Clear Of Tongue

Implement may become tongue light when unhooked from tractor.

PART #USA



PART #8500

8500

8500 NITROMASTER TOOLBAR ASSEMBLY PROCEDURE

Your 8500 Nitromaster Toolbar is shipped with small parts and hardware packed in boxes marked for the different sections of the toolbar. If you find any items missing, please contact Ag Systems, Inc. immediately.

Note: In this manual "left hand" and "right hand" are determined by standing behind the toolbar looking in the direction of travel.

- Step 1 Select a smooth level surface for the assembly of your Nitromaster Toolbar.
- Step 2 Refer to the illustration for the center section. Place the center section (item 1) upon (4) steel saw horses, one at each corner of the frame. Do not place the hinge plates on the saw horses.
- Step 3 Install the bogie arms (item 48) left hand and (item 48A) right hand to the center section with the hinge pins (item 49) and appropriate hardware.
- Step 4 Install the walking wheel assembly (item 61 & 62) to the bogie arms with the pivot pins (item 66) and appropriate hardware.
- Step 5 Install the torsion tube assembly (item 32). Slide the end bearing assembly (item 36) on to each end of the torsion tube assembly. Mount the end bearings to the support plates with the appropriate hardware. Mount the center bearings on the support plates and tighten snug only. Check that the torsion tube can rotate freely. Adjust the bearing mounting if needed and tighten the hardware securely.
- Step 6 Install the link arms (item 35) so that the bent bracket is on the top side and the open end is up. (this later supports the travel lock (item 58) for storage.) Assemble with the cylinder pins (item 56).
- Step 7 Mount the poles (item 2) left hand and (item 3) right hand to the toolbar with the pivot pin (item 29) and appropriate hardware. Assemble the hitch mount (item 5) to the poles with the grade 8 bolts (item 13) and appropriate hardware.
- Step 8 Install the pole pivot link (item 33) between the poles and the torsion tube assembly with the appropriate hardware.
- Step 9 Place the center section wheel lift cylinders (item 55) size 4 x 12 into position with the body towards the frame and the shaft on the bogie arm. Mount with the cylinder pins supplied.
- Step 10 Mount the wheels and tires on the hubs. The toolbar parts list indicates the tires available.
- Step 11 Mount the jack (item 4). Mount the hitch (see items 6 to 11) with the hitch pin (item 12). When item 6 is not used, it is stored on the peg provided on the right hand pole. If the adapter clevis (item 9) is used, make sure the hitch is installed with the clevis towards the bottom (as illustrated).
- Step 12 You may mount the miscellaneous items (item 15 to 28) on the pole at this time, or as convenient.
- Mounting the Primary and Secondary Wings**
- Step 13 Refer to the illustration for the wings. Place the primary wings (item 1) left hand and (item 1) right hand on steel saw horses and attach to the center section with the hinge pin (item 3). Secure the pin with the bolt (item 9) and all parts (item 7 to 11). Position the spacer (item 4) and assemble the nut (item 5) and install the cotter pin (item 6).
- Step 14 Assemble the wheel pivot arm (item 21) left hand and (item 21) right hand to the wing with the pivot pin (item 18) and appropriate hardware.

- Step 15 Place the wing wheel lift cylinder (item 15) size 3 ¾ x 12 in position with the body towards the frame and the shaft on the pivot arm. Assemble with the cylinder pins supplied. If your toolbar is not equipped with secondary wings, item 27 and beyond are not required. Skip steps 16 to 19 and continue at step 20.
- Step 16 Place the secondary wings (item 27) left hand and (item 27) right hand on suitable supports and attach to the primary wings with the hinge pin (item 39) and cotter pin (item 40).
- Step 17 If so equipped, assemble the shank mounting stubs (item 46) to the secondary wings with the appropriate hardware.
- Step 18 Assemble the wheel pivot arm (item 21) left hand and (item 21) right hand to the wing with the pivot pin (item 18) and appropriate hardware.
- Step 19 Place the wing wheel lift cylinder (item 29) size 3 1/2 x 12 in position with the body towards the frame and the shaft on the pivot arm. Assemble with the cylinder pins supplied.
- Step 20 Mount the wheels and tires on the hubs for both the primary and secondary wings. The toolbar parts list indicates which tires are available for your toolbar.

Mount the Wing Fold Cylinders

- Step 21 Refer to the illustration for the center section. Mount the hydraulic cylinders (item 43) size 4 x 36, on the toolbar with the body on the center section and the shaft towards the wing. DO NOT attach the shaft at this time.
- Step 22 Refer to the illustration for the primary and secondary wings. Mount the hydraulic cylinders (item 31) with the body on the primary wing and the shaft towards the secondary wing. DO NOT attach the shaft at this time.
- Step 23 Generously grease all hinge and pivot points. Do not overlook the pole mounting points and the torsion tube bearing assemblies.

Assemble the Hydraulic System and Purge

- Step 24 Refer to the "Hydraulic Plumbing Schematic" illustration applicable to your machine. Assemble the fittings to all the cylinders. Note that the fittings on the butt end of the CENTER WHEEL CYLINDERS must be on top of the cylinder. The fittings at the shaft end must be on the side of the cylinder.
- Step 25 Assemble the hydraulic hoses per the "hydraulic plumbing" schematic illustration. Secure the hoses at the primary wing pivot points with the clamp plate (item 12) and appropriate hardware.
- Step 26 Purge the air from the hydraulic system.
- (A) Pressurize the wheel lift hydraulic circuit. Fully extend the wheel cylinders and remove the assembly supports. With the wheel cylinders fully extended circulate the oil for approximately two minutes.
 - (B) Partially retract the cylinders. All wheels should lift simultaneously. Stop part way through the stroke and watch for any wheels sagging. This would indicate there is air in the system.
 - (C) To purge the air from the system, extend the cylinders and circulate the oil for approximately two minutes. Repeat step "B" until the system operates satisfactorily.
 - (D) Pressurize the wing fold cylinders. CAUTION: As the cylinder shafts are extending, be careful that the shafts do not get scratched or damaged in any way. With the cylinders fully extended circulate the oil for approximately two minutes. Retract the cylinders and repeat the above procedure. This should eliminate all air from the hydraulic systems.
- Step 27 Refer to the illustration for the toolbar center section. Assemble the shaft end of the hydraulic cylinders (item 43) to the primary wings with the clevis pin (item 45) and appropriate hardware.

- Step 28 Refer to the illustration for the wings. Assemble the pivot link (item 37) to the cylinders (item 31) with the clevis pin (item 33) and appropriate hardware. Assemble the pivot link to the secondary wing with the cylinder pins supplied (item 38).
- Step 29 Mount the wing hook assembly (item 42) on the primary wing and the hook retainer (item 41) on the secondary wing with the u-bolts (item 43) and appropriate hardware. These items should be positioned equal distance from each side of the pivot pin. The location is not critical, but make sure they do not interfere with the shank mount locations.
- Step 30 Refer to the shank location illustrations. Determine which illustration applies to your toolbar. Mount the shanks, knives and (if used) coulters and disk sealers per the illustration using the stagger brackets where indicated.
- Step 31 Mount the field hitch if so equipped. Refer to the field hitch illustration for appropriate hardware.
- Step 32 **NH3 APPLICATION:** Refer to the illustration titled NH3 Stands and Brackets. Mount the stands and brackets supplied in an appropriate location. Attach the chemical hoses and mount the application components supplied. Refer to pages 47 and 48 of this manual. Install the break-away coupling device per manufacturers instructions. See page 48A of this manual for basic operation and maintenance information.
- Step 33 Secure all hydraulic and chemical hoses in a safe manner. Make sure all hardware is securely tightened. Attach the information and warning decals supplied in the locations indicated.
- Step 34 Fold the wings and raise the machine to the full transport height. Position the transport locks (item 58) on the extended shafts of the wheel lift cylinders on the center section and secure the transport locks with the pins (item 59 & item 60). Release the hydraulic pressure and lower the machine so that it is supported by the transport locks.
- CAUTION: BEFORE MOVING THE MACHINE.** Read the operating instruction and warnings on the page following these assembly instructions.
- Step 32 Your 8500 Nitromaster Toolbar is now fully assembled and **READY TO GO TO WORK.**

OPERATING INSTRUCTIONS

USE OF DEPTH CONTROL SPACERS

WARNING:

Failure to use, or incorrect use of the depth control spacers on the center section lift cylinders will result in voiding the equipment warranty.

Correct use of the lift cylinder depth control spacers is needed to maximize equipment performance. Incorrect use will cause the equipment to operate at uneven depths and even result in equipment damage.

To gain maximum performance from your equipment, the depth control spacers that have been provided with your equipment must be used when you place your equipment in the field. It is imperative that an equal number of spacers of equal size are placed on each of the center section lift cylinders before placing your equipment in service. Failure to do so may cause damage and result in voiding the equipment warranty. Use of stroke control spacers (depth control spacers) on the wing lift cylinders is not recommended, or necessary when spacers are properly placed on the center section lift cylinders.

To set the equipment to the proper depth for your field conditions, place the toolbar in the field to the desired tillage depth. Using the cylinder spacers provided with your equipment, place an equal number of spacers of equal size on both of the center section lift cylinders. It is very important that both center section lift cylinders are functioning with the same size of cylinder spacers before you continue to operate your equipment. If you require deeper depth, lift the equipment, remove and replace a spacer with a thinner spacer. If you require a shallower depth, remove a spacer and replace it with a thicker spacer. Once the equipment has been set to your desired tillage depth by using the correct depth control spacers you will not need to change them.

USE OF TRANSPORT LOCK

WARNING:

Failure to use the transport locks may result in equipment damage or personal injury. Equipment transport locks are provided for safety when transporting equipment over the road and should remain with the equipment. The transport locks also prevent the equipment from settling or dropping when the equipment is disconnected from the hydraulic power source. When you are finished with a field and you find it necessary to move the equipment to a new location, simply raise the toolbar out of the ground and place the transport locks provided on to the lift cylinder. You do not need to remove the spacers for transport. Slide the spacers up on the cylinder rod far enough so that the transport lock will pass below and around the spacers. Then secure the transport locks with the pins provided. When you are finished with the equipment and it is to be parked, it is imperative to place the transport locks around the lift cylinder rods to prevent the equipment from settling.

When operating your equipment in the field the lift wheels must be in contact with the ground at all times. Operating the equipment with the lift wheels retracted until the wheels are completely off the ground will be considered misuse of the equipment and may result in voiding the equipment warranty.

COULTER and DISK SEALER MOUNTING INFO

With the toolbar parked on hard level ground fold out the wings and lower the toolbar so that it is supported on the knives. The toolbar should be level. If necessary, unhitch the toolbar and adjust the jack as required.

SETTING THE COULTER DEPTH: Assuming a working depth for your knife of 8 inches (dim A), adjust one coultter blade to a distance of 4 inches (dim B) above the knife point. This will run the blade 4 inches in the ground.

Measure the distance that the 1 x 3 bar extends above the mounting bracket (dim C). Adjust all coulters to this dimension.

SETTING THE DISK SEALER DEPTH:

When the working depth is 8 inches, position one disk sealer assembly on the shank so that the blades are 6 inches (dim D) above the knife point. Measure the distance from the spring bundle bracket to the disk sealer bracket (dim E). Adjust all disk sealers to this dimension. This will run the disk sealers 2 inches in the ground.

OTHER WORKING DEPTH: modify these dimensions in relation to your working depth. If your knife is 10 inches in the ground (dim A), the dimension from the coultter blade to the knife point (dim B) would be 6 inches. The distance to the disk sealer (dim D) would be 8 inches. This "knife to blade" relationship would apply regardless of what combination of "AgSystems" bracket, shank, knife, coultter and disk sealer is used.

NOTE::

It is important that the coultter and disk sealer blades are not set excessively deep. The coultter blades should be set just deep enough to cut the surface trash. Coulters set too deep will cause the toolbar to float on the coulters and not allow your gauge wheels to contact the ground. Intermittant contact with the ground will cause excessive wear on the hydraulic cylinder clevises and the mounting lugs. Coulters running too deep could also form a trench that will not seal properly and allow excessive NH3 to escape into the atmosphere (smoking).

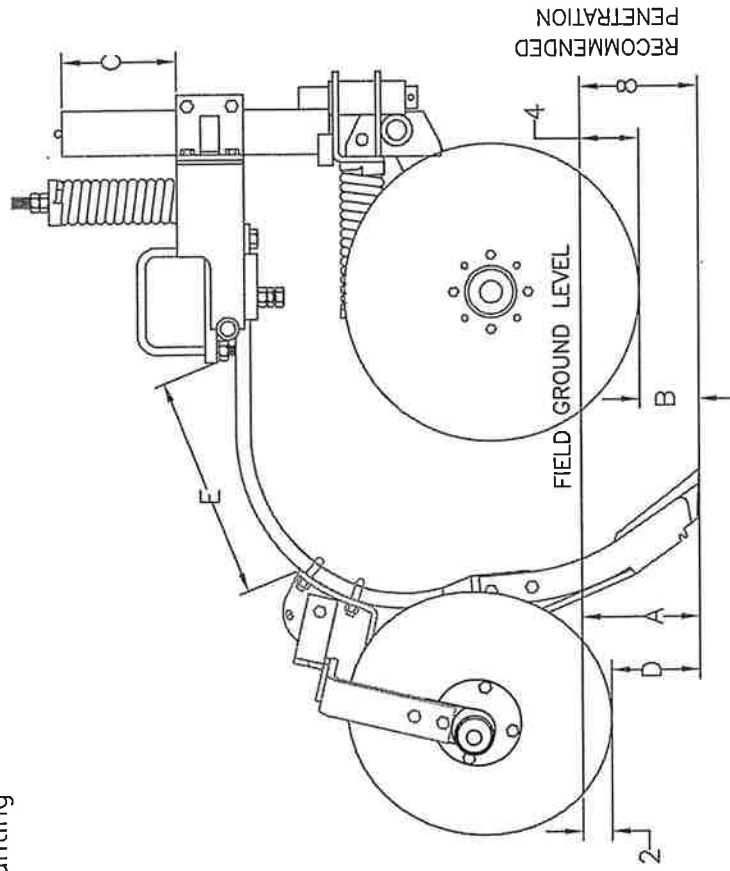

AG SYSTEMS INC. HUTCHINSON MN. 55350	
DRAWN BY J.N.	NAME COULTER/SEALER ADJUSTMENT
FIRST USED	DATE 07/01/06
REV.	DATE
PART NUMBER	SPGBDLSHK

8500 SERIES TOOLBAR
16 1/2' CENTER SECTION

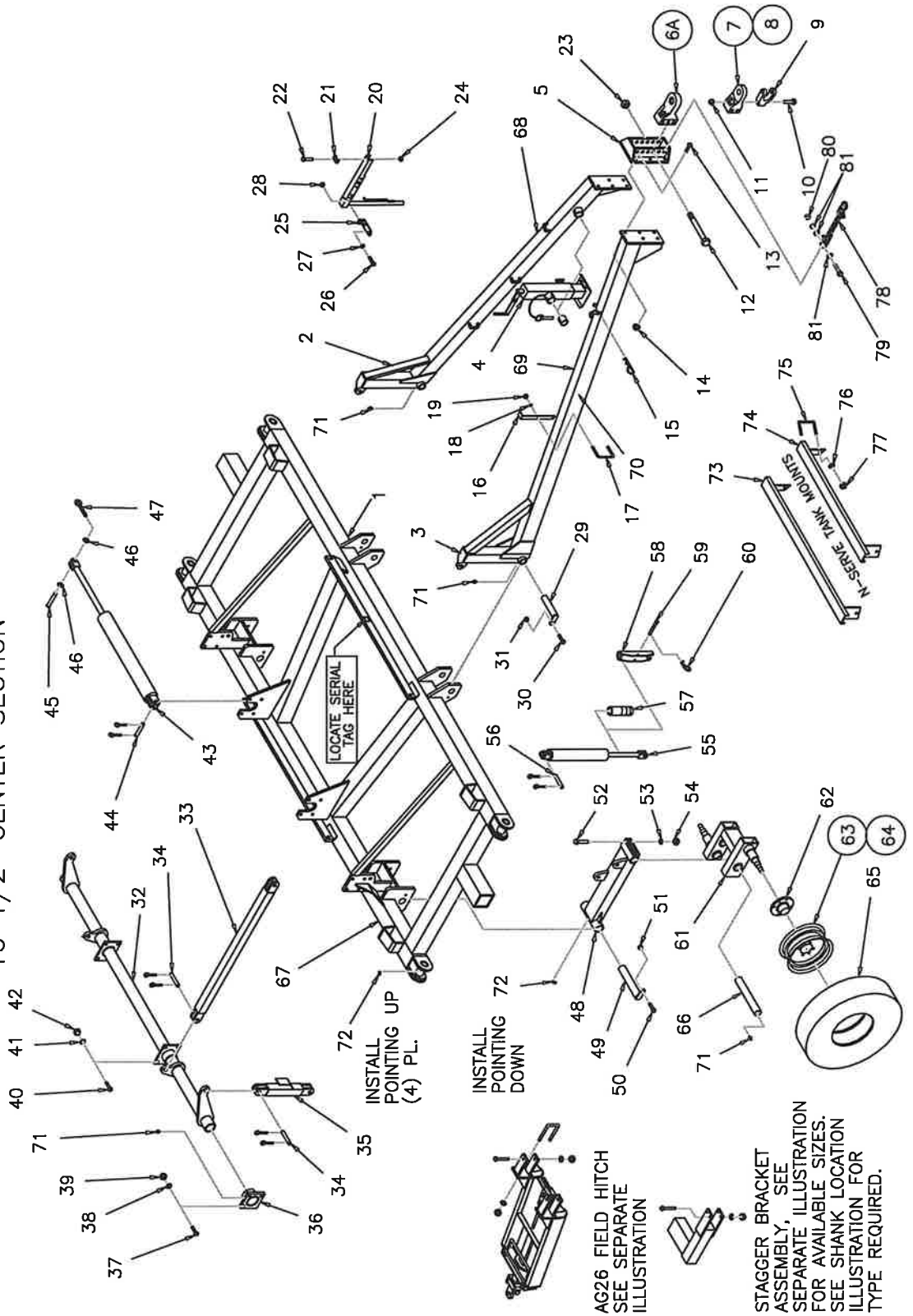

8500 SERIES TOOLBAR PARTS LIST

16 1/2' CENTER SECTION

ITEM	PART NO.	DESCRIPTION	QTY.	ITEM	PART NO.	DESCRIPTION	QTY.
1	47007924	CENTER SECTION	1	42	18418400	HEX NUT, 3/4-10NC.	8
2	47007922	POLE, LEFT HAND	1	43	47300095	HYD. CYLINDER, CENTER (4 X 36)	4
3	47007919	POLE, RIGHT HAND	1	44	47003514	CYLINDER PIN KIT (1 X 4) (2 PINS)	2
4	70924	JACK COMPLETE, (FINISH PAINTED)	1	45	18549054	CLEVIS PIN, (1 X 5)	4
				46	18852200	FLATWASHER 1" I.D.	8
				47	18560826	COTTER PIN (3/16 X 1 1/2)	4
				48	47004424	BOGGIE ARM, L.H.	1
				49	47004425	BOGGIE ARM, R.H.	1
5	47008355	HITCH MOUNT	1	49	47004440	HINGE PIN, BOGGIE ARM	2
6A	PP53XLA	PERFECT HITCH, (CATEGORY 5)	1	50	18057430	BOLT, 1/2-13NC. X 2	2
				51	18497400	NUT, FLANGED 1/2-13NC.	2
7	Pi-301V3C	PERFECT HITCH ASSY. (1 1/2 D'PIN)	1	52	18058436	BOLT, 3/4-10NC. X 3	8
		INCLUDES ITEMS 8 TO 11		53	18891800	LOCKWASHER, 3/4	8
8	PPI-301V3	PERFECT HITCH, BASE HITCH	1	54	18418400	HEX. NUT, 3/4-10NC.	8
9	PPI-208VR	PERFECT HITCH CLEVIS (1 1/4 D'PIN)	1	55	47005459	HYD. CYLINDER, CENTER WHEELS	2
		(5400 LBS.) VERTICAL CAPACITY		56	47003514	REPHASING (4 X 12) 1 3/8 SHAFT	2
10	18058452	BOLT, 3/4-10NC. X 5, GR. 8	1	57	47005455	CYLINDER PIN KIT (1 X 4) (2 PINS)	2
11	18458452	LOCKNUT, 3/4-10NC. GR. 8	1	58	47010150	SET, DEPTH CONTROLS, 1 3/8 SHAFT	2
12	18098508	BOLT, 1"-8NC. X 8, GR. 8	3	59	18541254	TRAVEL LOCK- 1 3/8 SHAFT	2
13	18098435	BOLT, 3/4-10NC. X 2 1/2, GR. 8	8	60	18590916	CLEVIS PIN, TRANSPORT LOCK	2
14	18458452	LOCKNUT, 3/4-10NC. GR. 8	10			HAIRPIN BRIDGE, TRANSPORT LOCK	2
15	18590094	HAIRPIN BRIDGE, (#8) 3/16 DIA.	1			WALKING WHEEL ASSEMBLY	
16	47010170	BRACKET, DEPTH CONTROLS	2	47994429	INCLUDES ITEMS 61 & 62		
17	47001028	U-BOLT, 3/8-16NC	2	61	47004429	BOGGIE FRAME	2
18	18891200	LOCKWASHER, 3/8	4	62	47009712	HUB COMPLETE, FOR PARTS SEE SEPARATE ILLUSTRATION	4
19	18436800	HEX. NUT, 3/8-16NC.	4	63	47006023	WHEEL RIM, 22.5 X 8.25	4
20	47005087	PIVOTING HOSE BRACKET	1	64	20120012	WHEEL RIM, 14C X 16.1	4
21	47015091	HOSE CLAMP	4	65	179906	VALVE STEM	4
22	18056832	BOLT, 3/8-16NC. X 2 1/4	2	66	32297	TIRE, 11R X 22.5 TRANSPORT	4
23	18439000	HEX NUT, 1"-8NC.	6	67	47004437	TIRE, 16.5 X 16.1, 10 PLY	4
24	18459200	LOCKNUT, "NYLOK" 3/8-16NC.	2	68	699107	PIVOT PIN, BOGGIE FRAME	2
25	47005092	GAUGE BRACKET,	1	69	699104	DECAL, AG-SYSTEMS INC	2
26	18056824	BOLT, 3/8-16NC. X 1 1/4	1	69	699100	DECAL, CAREFUL-CLEAR MACHINE	1
27	18811200	FLAT WASHER, 3/8	1	70	18901805	DECAL, WARNING-CLEAR TONGUE	1
28	18496800	FLANGE NUT, 3/8-16NC.	1	71	18901806	DECAL, NITROMASTER 8500	2
29	47004443	PIVOT PIN, POLE	2	72	18901807	GREASE ZERK, STRAIGHT (INSTALLED)	10
30	18057430	BOLT, 1/2-13NC. X 2	2	73	47005773	GREASE ZERK, 90 DEG. (INSTALLED)	6
31	18497400	FLANGE NUT, 1/2-13NC.	2	74	47005772	REAR CHANNEL (N-SERVE)	1
32	47007930	TORSION TUBE ASSEMBLY	1	75	47006545	FRONT CHANNEL (N-SERVE)	1
33	71897	POLE PIVOT LINK	2	76	18891400	U-BOLT, 1/2-13 NC	4
34	47003513	CYL. PIN KIT (1X3 1/2) (2 PINS)	4	77	18447400	LOCKWASHER, 1/2" ZINC	8
35	47004408	LINK ARM, WHEEL STRUT	2	78	PPSC4156BS	NUT, HEX 1/2-13 NC ZC	8
36	47004402	END BEARING, TORSION TUBE	2	79	18059061	CHAIN, SAFETY 1/2" X 56" LG	1
37	18058436	BOLT, 3/4-10NC. X 3	8	80	18459002	BOLT HEX CAP GR5 NC ZC 1 X 4	1
38	18891800	LOCKWASHER, 3/4	8	81	18852200	NUT NYLOCK 1 GR 5	1
39	18418400	HEX. NUT, 3/4-10NC.	8			WASHER FLAT 1" SAE ZC	3
40	18058434	BOLT, 3/4-10NC. X 2 1/2	8			(ITEMS 78-81 CAN BE ORDERED AS A KIT P/N:47090314)	
41	18891800	LOCKWASHER, 3/4	8				

8500 SERIES WINGS
PRIMARY AND SECONDARY

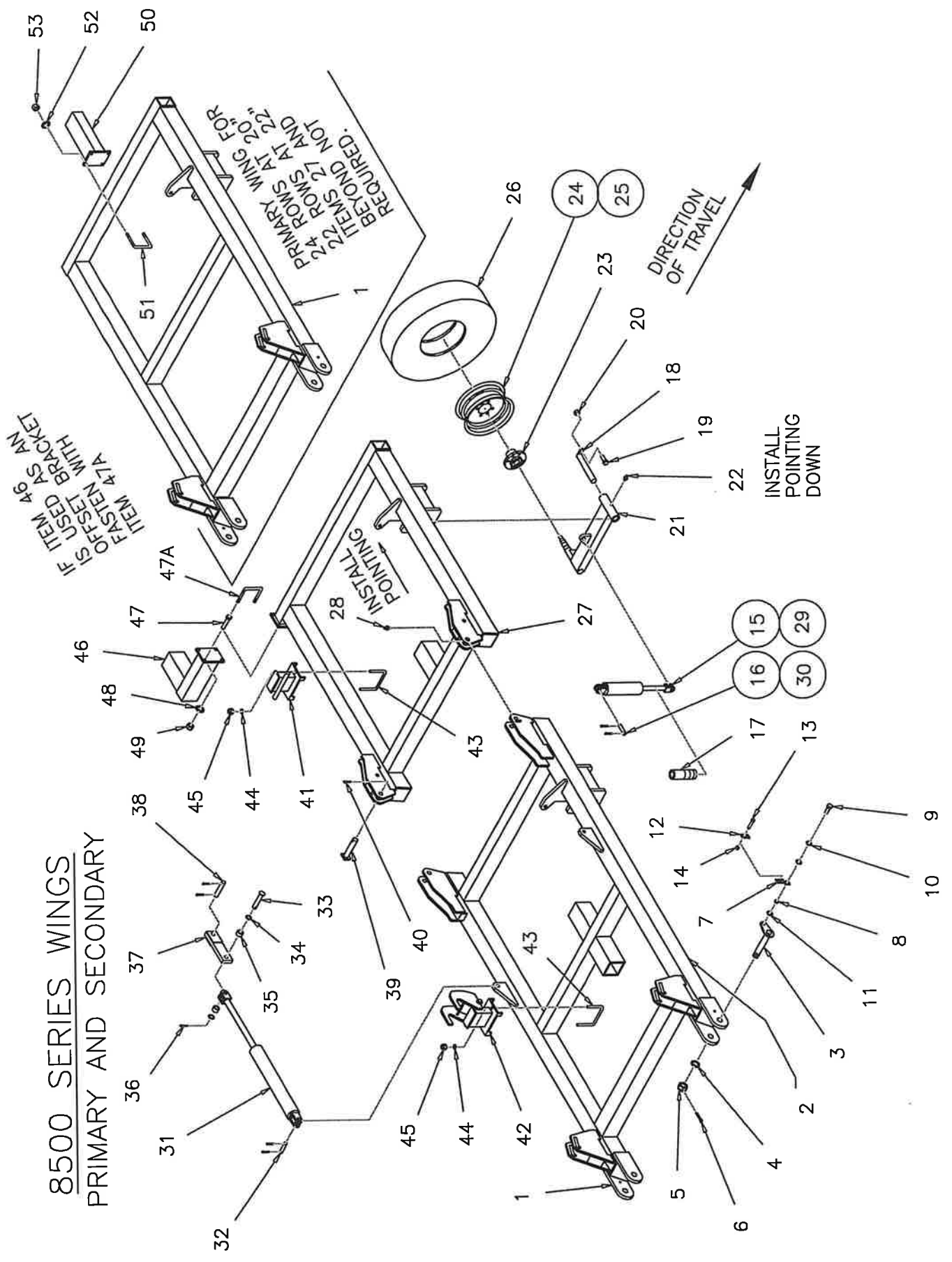

8500 SERIES WINGS

PARTS LIST

PRIMARY AND SECONDARY

85KWNGLST
REV 09-08-23

ITEM	PART NO.	DESCRIPTION	QTY.	ITEM	PART NO.	DESCRIPTION	QTY.
1	47004445	PRIMARY WING, L.H.(21 ROW X 30")	1	27	47005319	SECONDARY WING, L.H.(21 ROW X 30")	1
	47004446	PRIMARY WING, R.H.(NOT SHOWN)	1		47005320	SECONDARY WING, R.H.	1
		COMMON FOR (23 ROW X 30") AND (24 ROW X 30") AND (25 ROW X 30") AND (61 ROW X 12")			(23 ROWS X 30")	(24 ROWS X 30") (25 ROWS X 30")	
	47004462	PRIMARY WING, L.H.			47004472	SECONDARY WING, L.H.	
	47004463	PRIMARY WING, R.H.			47004473	SECONDARY WING, R.H.	
						(61 ROWS X 12") ONLY	
		COMMON FOR (24 ROW X 20") & (22 ROW X 22")			47004475	SECONDARY WING, L.H.	
	47004485	PRIMARY WING, L.H.			47004476	SECONDARY WING, R.H.	
	47004486	PRIMARY WING, R.H.			(51 ROW X 12") AND (43 ROW X 15")		
					47004482	SECONDARY WING, L.H.	
					47004483	SECONDARY WING, R.H.	
				28	18901806	GREASE ZERK. 90 DEG. (INSTALLED)	4
2	699101	DECAL, DANGER-FALLING WINGS	2			ALSO USE ITEMS 21 TO 26	
3	47004488	HINGE PIN, PRIMARY WING	4	29	47005056	HYDRAULIC CYLINDER (3 1/2 X 12)	2
4	47004491	PIN SPACER	4	30	47003514	CYLINDER PIN KIT (1 X 4) 2 PINS	2
5	18489150	SLOTTED NUT, 1 3/4-12NF	4	31	47300094	HYDRAULIC CYLINDER (3 1/2 X 24)	4
6	18560009	COTTER PIN, 1/4 x 3	4	32	47003514	CYLINDER PIN KIT (1 X 4) 2 PINS	4
7	47004575	HOSE STAND-OFF BRACKET	4	33	18549054	CLEVIS PIN (1 X 5)	4
8	47004577	SPACER BUSHING	4	34	18852200	FLATWASHER, 1" SAE	8
9	18057430	BOLT, 1/2-13NC. X 2	4	35	47010441	ROLLER, CYLINDER LINK	8
10	18891400	LOCKWASHER, 1/2	4	36	18560826	COTTER PIN, 3/16 X 1 1/2	4
11	18811400	FLATWASHER, 1/2	8	37	47010163	PIVOT LINK	4
12	47004576	HOSE CLAMP PLATE	4	38	47003514	CYLINDER PIN KIT (1 X 4) 2 PINS	2
13	18045726	BOLT, 1/4-20NC. X 1 1/2	8	39	47004568	HINGE PIN, (2NDRY WING)	4
14	18457000	HEX. LOCK NUT, 1/4-20NC.	8	40	18561030	COTTER PIN, 1/4 X 2	4
15	47005449	HYDRAULIC CYLINDER (3 3/4 X 12)	2	41	47010151	WING HOOK RETAINER	2
16	47003514	CYLINDER PIN KIT (1 X 4) 2 PINS	2	42	47010149	WING HOOK ASSEMBLY	2
17	47005455	SET, DEPTH CONTROLS	4	43	47006950	U-BOLT, 5/8-11NC	4
18	47010313	HINGE PIN, GAUGE WHEEL	4	44	18891600	LOCKWASHER, 5/8	8
19	18057430	BOLT, 1/2-13NC. X 2	4	45	18417900	HEX. NUT, 5/8-11NC.	8
20	18497400	FLANGE NUT, 1/2-13NC.	4	46	47015048	SHANK MNTG. STUB, (STANDARD)	2
	47034492	PIVOT ARM ASSEMBLY, L.H.	2		47004470	SHANK MNTG. STUB, (61 ROW ONLY)	
	47034493	PIVOT ARM ASSEMBLY, R.H.	2	47	18057934	BOLT, 5/8-11NC. X 2 1/2	8
		INCLUDES ITEMS 21, 22 & 23		47A	47009847	U-BOLT, 5/8-11NC (OPTIONAL)	2
21	47004492	PIVOT ARM, L.H.	2	48	18891600	LOCKWASHER, 5/8	8
	47004493	PIVOT ARM, R.H.	2	49	18417900	HEX. NUT, 5/8-11NC.	8
22	18901806	GREASE ZERK. 90 DEG. (INSTALLED)	4	50	47004592	UTILITY MOUNT STUB (OPTIONAL)	2
23	47009712	HUB ASSEMBLY	4	51	47010154	U-BOLT, 5/8-11NC	4
24	47006023	WHEEL RIM, 22.5 X 8.25	4	52	18891600	LOCKWASHER, 5/8	8
25	20120012	VALVE STEM	4	53	18417900	HEX. NUT, 5/8-11NC.	8
26	179906	TIRE, 11R X 22.5, TRANSPORT (ALL)	4				

HUB ASSEMBLIES

8500HUB
09/08/23

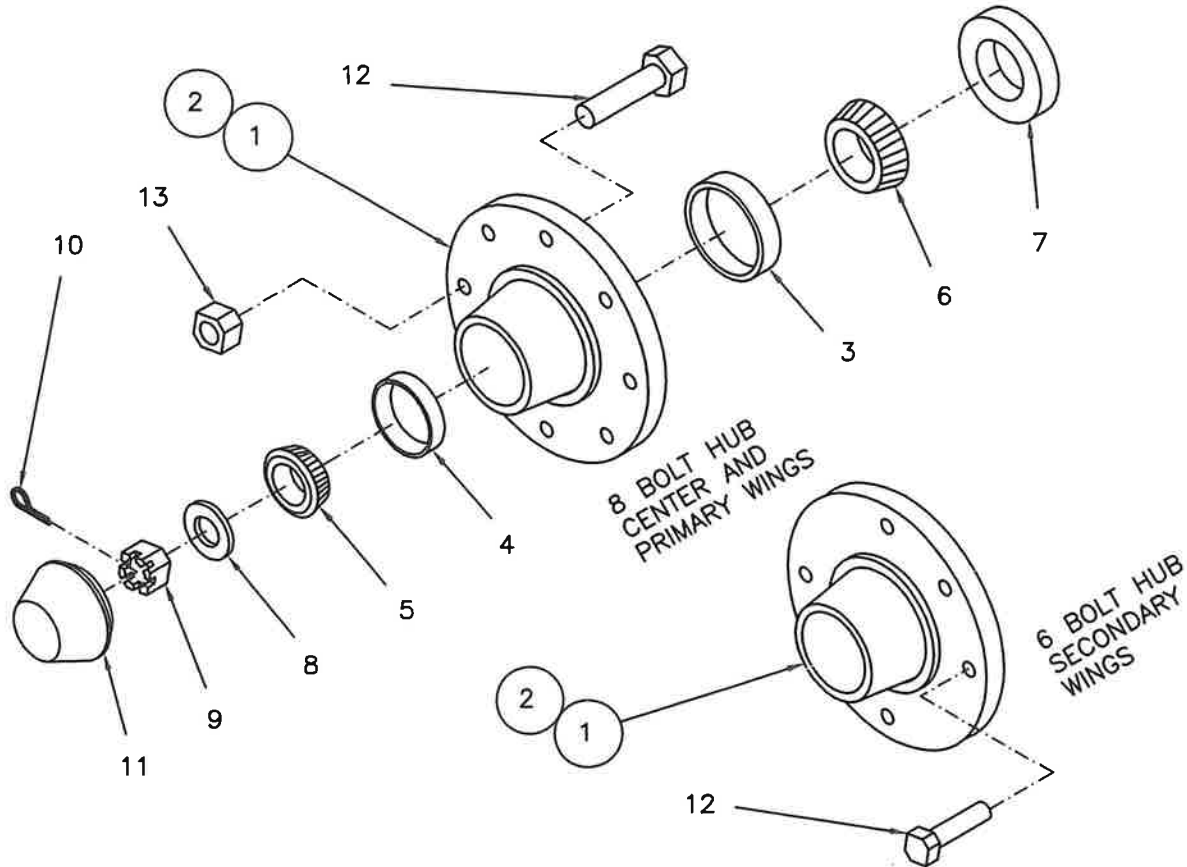

<u>ITEM</u>	<u>DESCRIPTION</u>	<u>6 BOLT PART NO.</u>	<u>8 BOLT PART NO.</u>	<u>QTY.</u>
1	HUB COMPLETE MFGR. PART NUMBER INCLUDES ITEMS 2 THRU 7 AND 11 THRU 13 ONLY	47009618 H618	47009712 HD812-1	1
2	HUB WITH RACES (# 3 & 4)	47005618	47005712	1
3	INNER BEARING RACE	47005520	47005372	1
4	OUTER BEARING RACE	47005510	47005272	1
5	OUTER BEARING CONE	47005548	47005279	1
6	INNER BEARING CONE	47005580	47005378	1
7	GREASE SEAL	47005030	47005017	1
8	SPINDLE WASHER, 1" SC	18000017	18000017	1
9	SPINDLE NUT, 1" UNF SC	18489100	18489100	1
10	COTTER PIN	18560828	18560830	1
11	DUST CAP	47005515	47005917	1
12	LUG BOLT (8 BOLT)	_____	47005041	8
12	LUG BOLT (6 BOLT WB12)	47005012	_____	6
13	LUG NUT (8 BOLT ONLY)	_____	47005040	8

HYDRAULIC PLUMBING SCHEMATIC

8500 SERIES TOOLBAR STANDARD ARRANGEMENT

W/ FOUR HYDRAULIC GAUGE WHEELS AND SECONDARY WINGS

85KPLMBSTD
ASBLT 10-16-09
REV 06-13-14

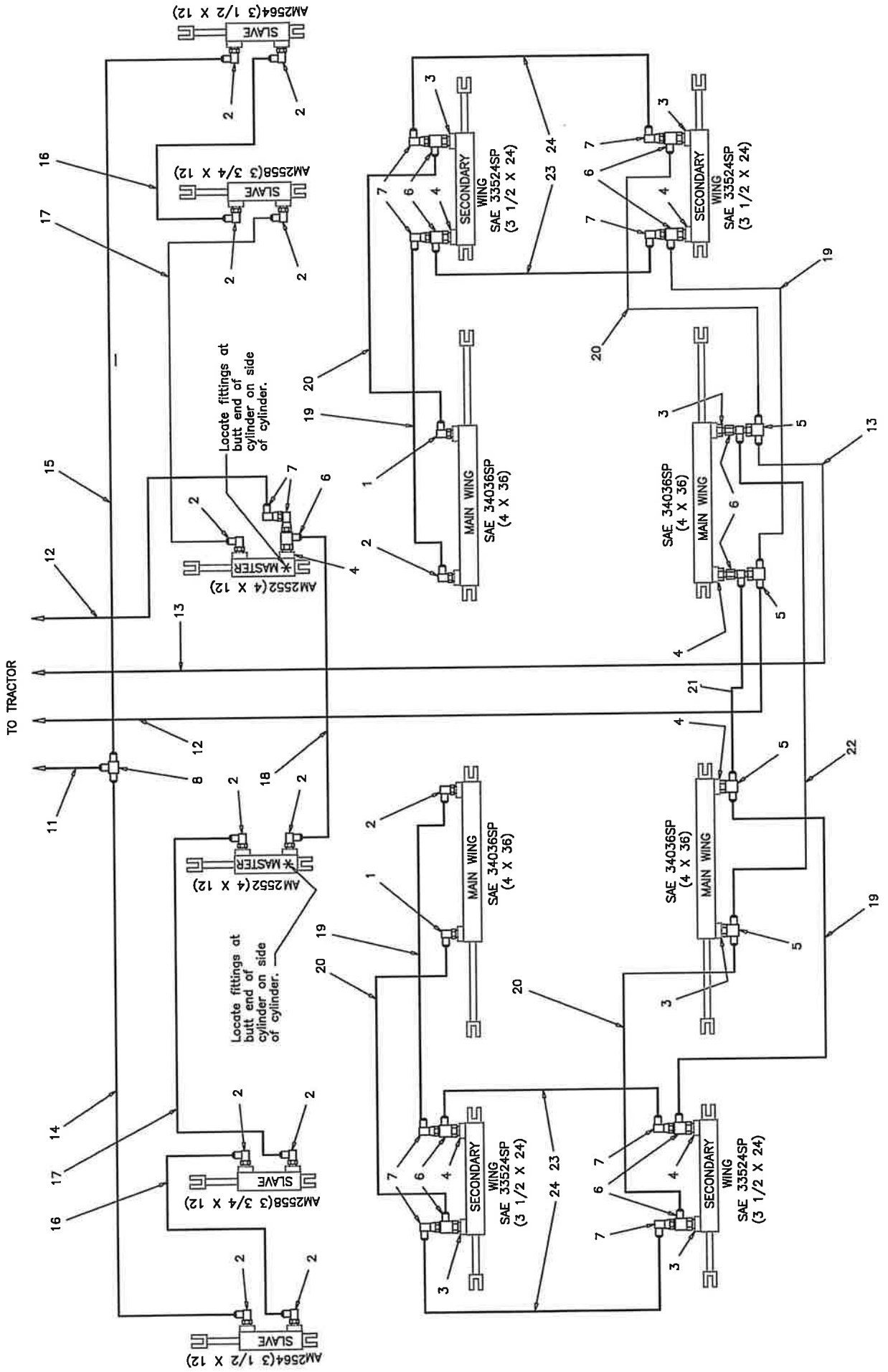

HYDRAULIC PLUMBING SCHEMATIC

HOSES AND FITTINGS

8500 SERIES TOOLBAR STANDARD ARRANGEMENT

W/ FOUR HYDRAULIC GAUGE WHEELS AND SECONDARY WINGS

85KPMBLSTD
ASBLT 10-16-09
rev 06-13-14

		HOSE PACKAGE. STANDARD TOOLBAR P.N. 850002		
<u>ITEM</u>	<u>PART NO.</u>	<u>DESCRIPTION</u>		<u>QTY</u>
11	609198	HOSE, 3/8 X 198"	- 1/2 MPT X #6 JICFS	1
12	609322	HOSE, 3/8 X 322"	- 1/2 MPT X #6 JICFS	2
13	609282	HOSE, 3/8 X 282"	- 1/2 MPT X #6 JICFS	1
14	609402	HOSE, 3/8 X 402"	- #6 JICFS BOTH ENDS	1
15	609318	HOSE, 3/8 X 318"	- #6 JICFS BOTH ENDS	1
16	609126	HOSE, 3/8 X 126"	- #6 JICFS BOTH ENDS	2
17	609270	HOSE, 3/8 X 270"	- #6 JICFS BOTH ENDS	2
18	609177	HOSE, 3/8 X 177"	- #6 JICFS BOTH ENDS	1
19	601310	HOSE, 3/8 X 166"	- #6 JICFS BOTH ENDS	4
20	609128	HOSE, 3/8 X 152"	- #6 JICFS BOTH ENDS	4
21	609810	HOSE, 3/8 X 106"	- #6 JICFS BOTH ENDS	1
22	608184	HOSE, 3/8 X 184"	- #6 JICFS BOTH ENDS	1
23	608108	HOSE, 3/8 X 108"	- #6 JICFS BOTH ENDS	2
24	608161	HOSE, 3/8 X 161"	- #6 JICFS BOTH ENDS	2

		FITTING PACKAGE, STANDARD TOOLBAR P.N. 850020		
<u>ITEM</u>	<u>PART NO.</u>	<u>DESCRIPTION</u>		<u>QTY</u>
1	6801-6-8R	ADAPTER ELBOW #6 MJIC X #8 M O-RING WITH .045 ORIFICE (BLACK FINISH)		2
2	6801-6-8	ADAPTER ELBOW #6 MJIC X #8 M O-RING		13
3	6400-6-8R	CONNECTOR, #6 MJIC X #8 M O-RING WITH .045 ORIFICE (BLACK FINISH)		6
4	6400-6-8	CONNECTOR, #6 MJIC X #8 M O-RING		7
5	6600-6	BRANCH TEE, #6 MJIC X #6 FJIC SWIVEL		4
6	6602-6	RUN TEE, #6 MJIC X #6 FJIC SWIVEL		11
7	6500-6	ELBOW, #6 MJIC X #6 FJIC SWIVEL		10
8	2603-6	UNION TEE, #6 MJIC		1

HYDRAULIC PLUMBING SCHEMATIC 8500 SERIES TOOLBAR 20" & 22" SPACING W/ TWO HYDRAULIC GAUGE WHEELS AND PRIMARY WINGS ONLY

85KPMB2022
PRO/06-13-14

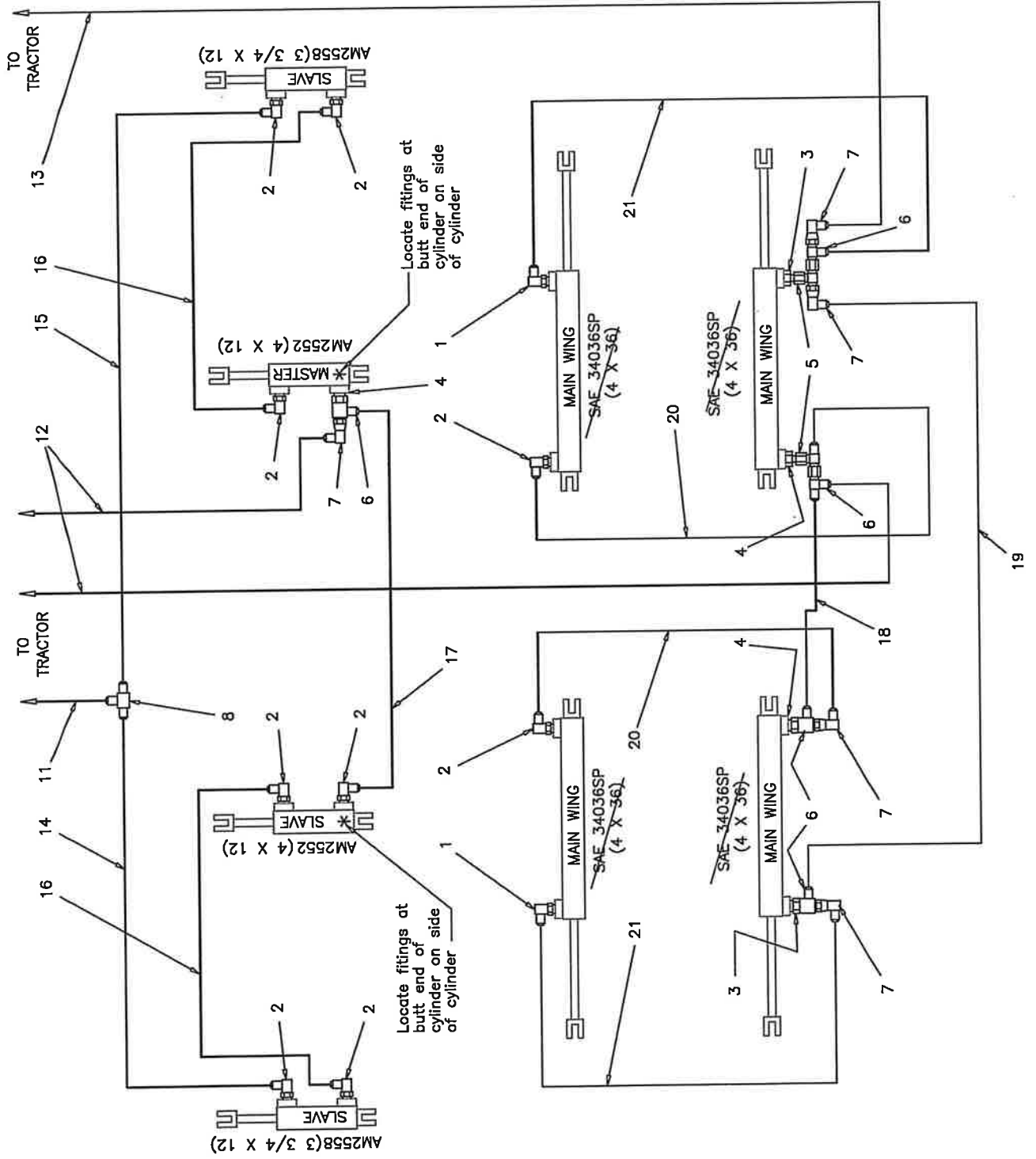

HYDRAULIC PLUMBING SCHEMATIC

HOSES AND FITTINGS

8500 SERIES TOOLBAR 20" & 22" SPACING

W/ TWO HYDRAULIC GAUGE WHEELS AND PRIMARY WINGS ONLY

HOSE PACKAGE. for 20 & 22" SPACING
P.N. 850001

<u>ITEM</u>	<u>PART NO.</u>	<u>DESCRIPTION</u>	<u>QTY</u>
11	609198	HOSE, 3/8 X 198" - 1/2 MPT X #6 JICFS	1
12	609322	HOSE, 3/8 X 322" - 1/2 MPT X #6 JICFS	2
13	609282	HOSE, 3/8 X 282" - 1/2 MPT X #6 JICFS	1
14	609270	HOSE, 3/8 X 270" - #6 JICFS BOTH ENDS	1
15	609200	HOSE, 3/8 X 200" - #6 JICFS BOTH ENDS	1
16	609300	HOSE, 3/8 X 300" - #6 JICFS BOTH ENDS	2
17	609177	HOSE, 3/8 X 177" - #6 JICFS BOTH ENDS	1
18	609810	HOSE, 3/8 X 106" - #6 JICFS BOTH ENDS	1
19	608184	HOSE, 3/8 X 184" - #6 JICFS BOTH ENDS	1
20	608108	HOSE, 3/8 X 108" - #6 JICFS BOTH ENDS	2
21	608161	HOSE, 3/8 X 161" - #6 JICFS BOTH ENDS	2

FITTING PACKAGE, for 20 & 22" SPACING
P.N. 850010

<u>ITEM</u>	<u>PART NO.</u>	<u>DESCRIPTION</u>	<u>QTY</u>
1	6801-6-8R	ADAPTER ELBOW #6 MJIC X #8 M O-RING WITH .045 ORIFICE (BLACK FINISH)	2
2	6801-6-8	ADAPTER ELBOW #6 MJIC X #8 M O-RING	9
3	6400-6-8R	CONNECTOR, #6 MJIC X #8 M O-RING WITH .045 ORIFICE (BLACK FINISH)	2
4	6400-6-8	CONNECTOR, #6 MJIC X #8 M O-RING	3
5	6600-6	BRANCH TEE, #6 MJIC X #6 FJIC SWIVEL	2
6	6602-6	RUN TEE, #6 MJIC X #6 FJIC SWIVEL	5
7	6500-6	ELBOW, #6 MJIC X #6 FJIC SWIVEL	5
8	2603-6	UNION TEE, #6 MJIC	1

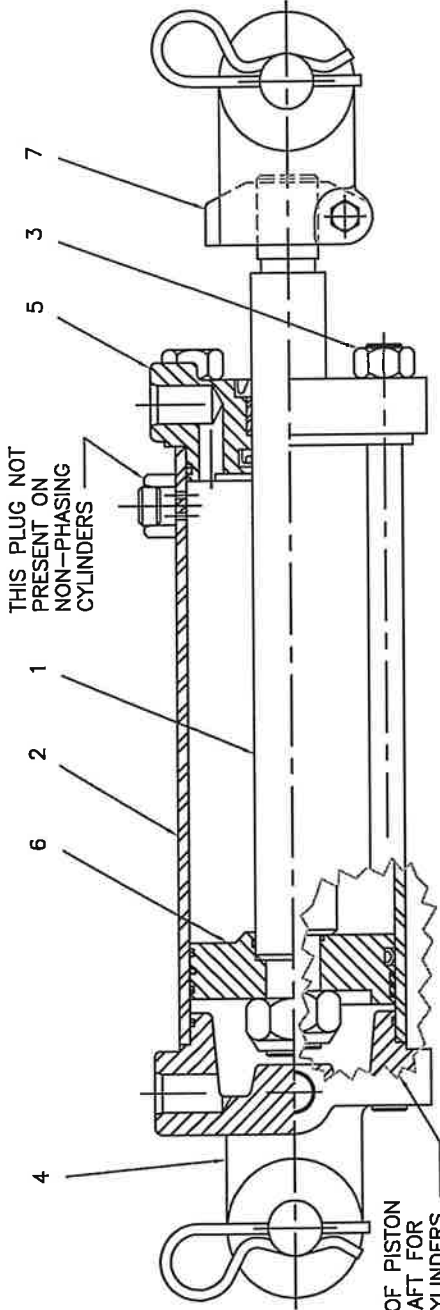

CONFIGURATION OF PISTON AND END OF SHAFT FOR NON-PHASING CYLINDERS

ITEM NO.	DESCRIPTION	MAIN CYL. CNTR. SCTN. 4 X 36 47300095 B400360BBAGA07A	WING CYL. 32-42 FT. BAR 3 X 24 47300093 B300240BBAA07F	WING CYL. 52 FT. BAR 3 1/2 X 24 47300094 B350240BBAA07A	WHEEL CYL. CNTR. MASTER 4 X 12 47005459 PMS-AM-2552A	WHEEL CYL. CNTR. ASSIST 3 X 12 47005414 AT-506	WHEEL CYL. WING, SLAVE 3 3/4 X 12 47005449 PMS-AM-2558A	WHEEL CYL. WING, SLAVE 3 1/2 X 12 47005056 PMS-AM-2564	QTY. REQ'D
1	SHAFT TUBE	011041438A	010729750A	010729750B	010700698	010600379	010600379	010600379	1
2	TIE ROD ASSM.	051938563A	051526063A	051726063A	061900598	051500708	061800022	061700366	1
3	BUTT	170301414	170201282	170201283	170301173	170201163	170301173	170201163	4
4	GLAND ASSM.	1419005SF	1415005SF	1417005SF	141900037	141500043	141800009	141700023	1
5	PISTON	08198BNSF	08158BGSF	08178BGSF	081900374	082500337	081800022	081700269	1
6	CLEVIS ASSM.	071900260	071500244	071700174	071900273	071500267	071800021	071700208	1
7	REPAIR KIT	100000326 47034000	100000423 47033500	100000577 47033500	100000577 47002552	100000423 470AT506	100000577 47032558	100000423 47002564	1

Repair kit items not available individually.

TIE ROD DISASSEMBLY--/--ASSEMBLY PROCEDURE.

With the cylinder removed from the machine, cleaned, drained of oil and fully retracted, proceed as follows.
DISASSEMBLY.

1. Secure the cylinder in a vice or other method to prevent rotation. Clean the immediate area so the parts can be laid out.
2. Remove the tie rod nuts. Pull the shaft assembly from the cylinder. Remove the tube item (2).
3. Loosen the clevis nut and remove the clevis item (7) from the shaft assembly.
4. Place the shaft assembly in a vice with brass or copper jaws so as not to damage the shaft.
5. Remove all seals from the butt, (item 4) gland assembly, (item 5) and piston (item 6) for replacement. Clean and inspect all parts for damage, (nicks, scratches, cracks etc.). Replace as necessary. If you have any question please contact Prince Engineering (712-277-4061)

REASSEMBLY.

1. Replace all the seals on items (4), (5), and (6) except, for non-phasing cylinders do not replace the small o-ring on the ID of the piston item (6) until you are ready to attach the shaft item (1).
2. For non-phasing cylinders, place the small o-ring seal for the piston over the shaft shoulder. Apply a light coat of grease to the seal. Slip the piston item (6) onto the turndown with the o-ring counterbore towards the shaft shoulder. Take care not to pinch the o-ring between the piston and the shoulder.
3. Replace the shaft end nut and secure.
4. Apply a light coat of grease to the seals on the gland item (5) and slip the gland over the shaft end. Be very careful not to damage the seals.
5. Slip the entire assembly into the lightly oiled tube, item (2) with the piston first making sure the tube slips over the OD seals of the gland.
6. Take the entire assembly from step 4 and slip the tube over the butt item (4). Align the ports in the butt and the gland and assemble the nuts to the tie rods and torque uniformly.
6. Test the reassembled cylinder for leaks and install in your machine. If you have any problems please contact Prince Engineering (712-277-4061)

STAGGER BRACKET ASSEMBLY

SPECIAL STAGGER BRACKETS AVAILABLE
 FITS 6 X 6 TUBE

STGBK6X6
 rev 04-29-13

CAN BE BOLTED DIRECTLY TO
 WINGS WITH MATCHING PLATE
 OR USE

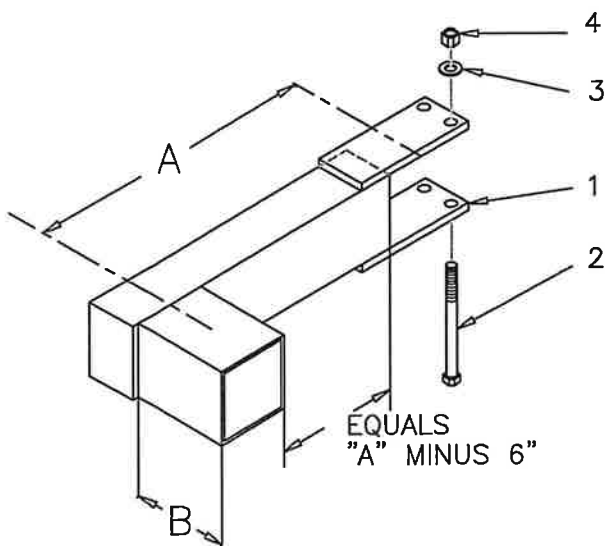
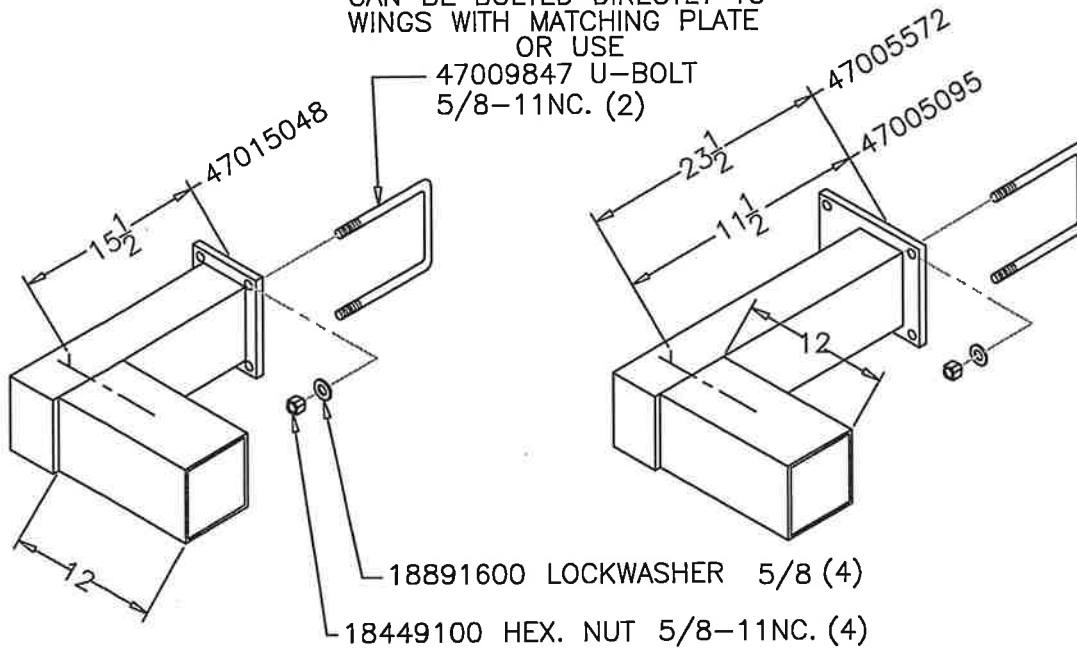

STANDARD STAGGER
 BRACKETS AVAILABLE
 FITS 6 X 6 TUBE

A= TUBE CENTERLINE TO TUBE CL
 TO DETERMINE THE
 DISTANCE BETWEEN
 THE TOOLBAR AND
 THE STAGGER BRACKET
 SHANK MOUNT TUBE
 DEDUCT 6 INCHES
 FROM DIM. "A"

ITEM	PART NO.	DESCRIPTION	DIM. A	DIM. B	QTY.
1	47004350	STAGGER BRACKET - SHORT	18 1/4	12	1
	47004354	STAGGER BRACKET - SHT/SPCL	18 1/4	15	1
	47004591	STAGGER BRACKET - SHT/SPCL	18 1/4	8	1
	47004356	STAGGER BRACKET - MEDIUM	24	12	1
	47004358	STAGGER BRACKET - LONG	30	8	1
	47004593	STAGGER BRACKET - XT.LONG	36	8	1
	47005032	STAGGER BRACKET - 2-XT.LONG	44	8	1
2	18058476	BOLT, 3/4-10NC. X 8 1/2	---	---	2
3	18891800	LOCKWASHER, 3/4	---	---	2
4	18418400	HEX. NUT, 3/4-10NC.	---	---	2

AG26 FIELD HITCH ASSEMBLY

FOR 8500 SERIES TOOLBAR

FITS 6 X 6 TUBULAR FRAME

AG268500

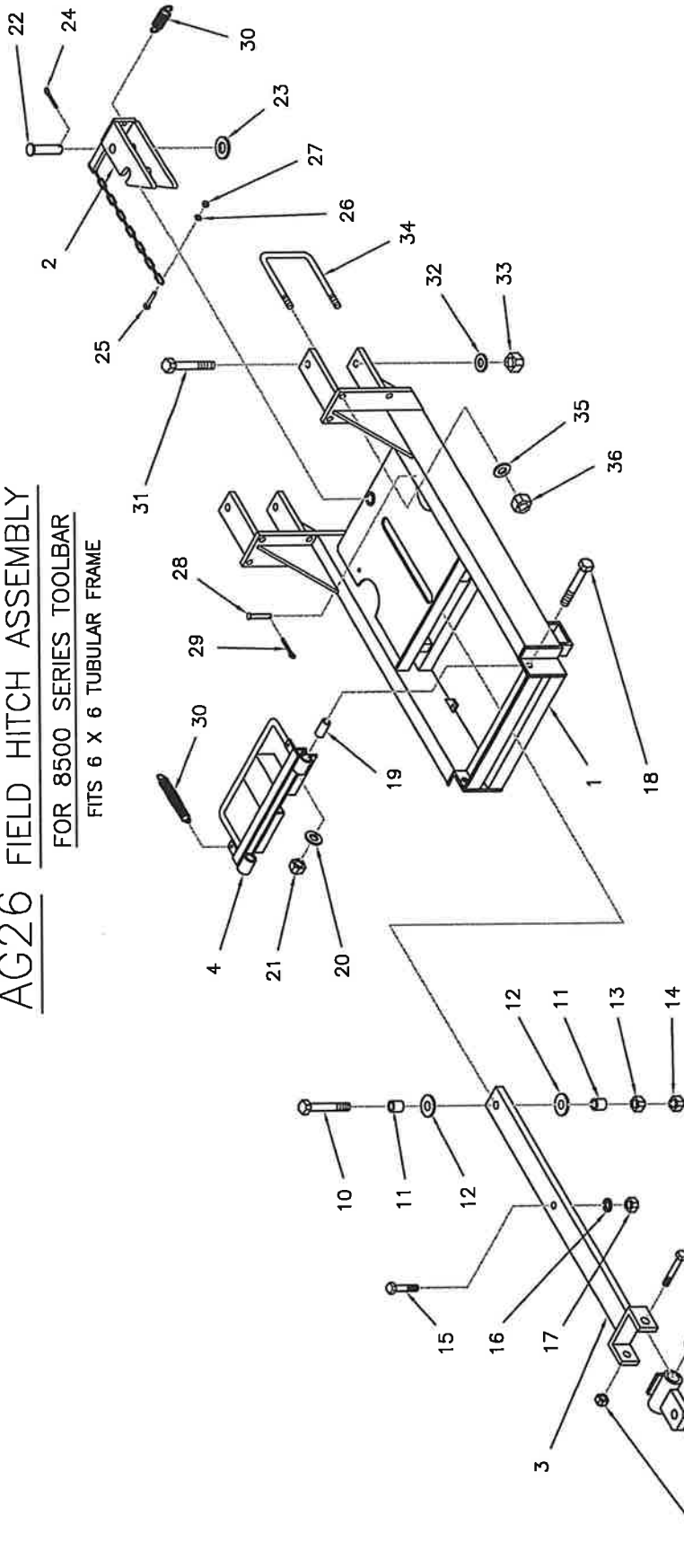

ITEM	PART NO.	DESCRIPTION	QTY.	ITEM	PART NO.	DESCRIPTION	QTY.
1	40268500	HITCH ASSEMBLY COMPLETE	1	18	18057940	BOLT, 5/8-11NC. X 3 1/2	2
2	40268501	INCLUDES ITEMS, 1 TO 36	1	19	47008877	PIVOT BUSHING, 5/8 I.D.	2
3	47009887	HITCH ASSEMBLY, LESS MOUNTING BOLTS	1	20	18851600	FLATWASHER, 5/8 NOM. I.D.	2
4	47009882	INCLUDES ITEMS, 1 TO 30	1	21	18457900	LOCKNUT, 5/8-11NC.	2
5	47009885	MAIN FRAME, STANDARD	1	22	18541551	CATCH PIVOT PIN, 1 X 4	1
6	470098914	DRAWBAR CATCH	1	23	18842200	FLATWASHER, 1" SAE	1
7	470098918	DRAWBAR (SEE NOTE 1)	1	24	18560826	COTTER PIN, 3/16 X 1 1/2	1
8	470098919	DRAWBAR LOCK	1	25	18055722	BOLT, 1/4-18NC. X 1	1
9	470098920	DRAWBAR HITCH, 6 AND 7	1	26	18891000	LOCKWASHER, 1/4 NOM. I.D.	1
10	18459000	INCLUDES ITEMS, 6 AND 7	1	27	18435700	HEX. NUT, 1/4-18NC.	1
11	18098539	FIBER BUSHING	2	28	18541147	CLEVIS PIN, 5/16 X 2 1/4	1
12	47009459	SPACER BUSHING	1	29	18560622	COTTER PIN, 1/8 X 1	1
13	18852400	SPECIAL BOLT, 1-8NC. X 6 7/8	1	30	000018	EXTENSION SPRING	3
14	18417800	HEX. LOCKNUT, 1-8NC.	1	31	47992603	BOLT PKG. INCL. ITEMS, 31 TO 36	2
15	18458000	BOLT, 7/8-9NC. X 5 1/2	1	32	18058476	BOLT, 3/4-10NC. X 8 1/2	2
16	18038430	CATCH BUSHING, 7/8 I.D.	2	33	18891800	LOCKWASHER, 3/4 NOM. I.D.	2
17	18891800	FLATWASHER, 1 1/4 NOM. I.D. (SAE)	2	34	47009847	HEX. NUT, 3/4-10NC.	2
		HEX. NUT, 7/8-9NC.	1	35	18891600	U-BOLT, 5/8-11NC. (FOR 6X6 TUBE)	4
		LOCKNUT, 7/8-9NC.	1	36	18417900	LOCKWASHER, 5/8 NOM. I.D.	8
		BOLT, 3/4-10 NC. X 2	1			HEX. NUT, 5/8-11NC.	8
		LOCKWASHER, 3/4	1				
		HEX. NUT, 3/4-10NC.	1				

SPRING BUNDLE ASSEMBLY

FOR 6 X 4 BAR YEAR 2000 TO PRESENT
AND 6 X 6 BAR

SPECIFY U-BOLT SIZE (ITEM 15)

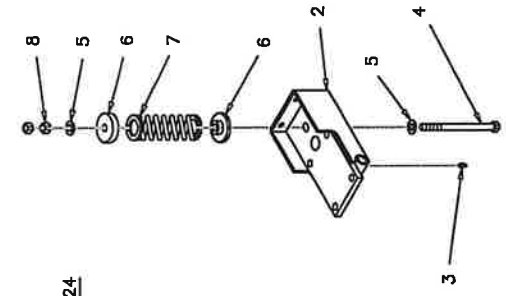
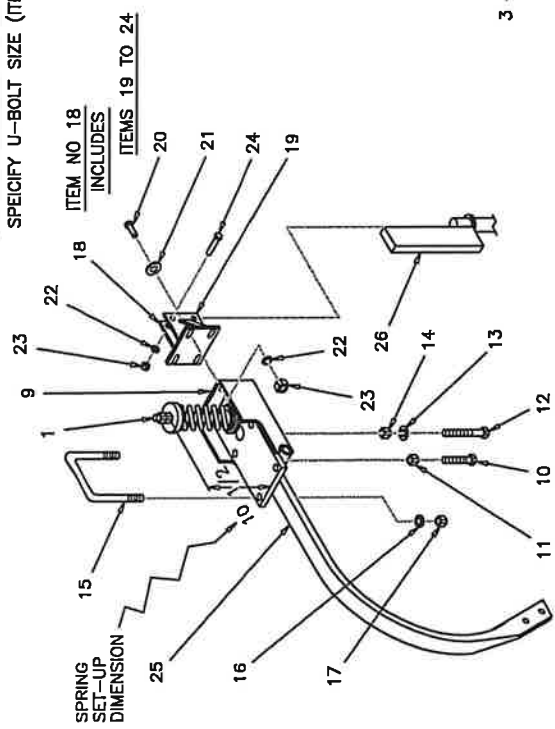

ITEM NO. 1
INCLUDES ITEMS 2 TO 8

ITEM NO. 9
INCLUDES ITEM 1
AND 10 TO 17

ITEM	PART NO.	DESCRIPTION	QTY.
1	47010082	SPRING SHANK MOUNT ASSEMBLY	1
2	47010189	SHANK MOUNTING BASE	1
3	18901805	GREASE ZERK	2
4	47007766	BOLT, 3/4-10NC, X 1 3/4	1
5	18851800	FLAT WASHER, 3/4	2
6	47007085	END COLLAR	2
7	47007565	COMPRESSION SPRING	1
8	18446890	HEX. NUT, 3/4-10NC. GR. 5	2
9	47020082	SPRING LOADED SHANK MOUNT COMPLETE (NO COULTER)	1
	47990082	(SHIPPING INFO) HARDWARE PACKAGE (INCLUDES ITEMS 10 TO 17)	1
10	18058429	BOLT, 3/4-10NC, X 1 3/4	1
11	18449003	HEX. JAM NUT, 3/4-10NC.	1
12	18058436	BOLT, 3/4-10NC, X 3	1
13	18891800	LOCKWASHER, 3/4	1
14	18418400	HEX. NUT, 3/4-10NC.	1
15	47007083	U-BOLT, 5/8-11NC. (4 X 6 BAR)	2
16	47009847	U-BOLT, 5/8-11NC. (6 X 6 BAR)	OR
17	18417900	LOCKWASHER, 5/8	4

SPRING LOADED SHANK MOUNTING

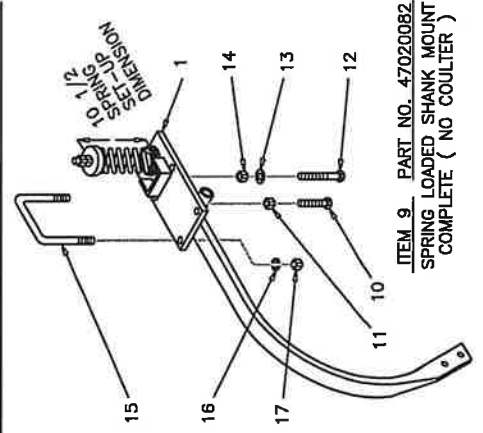

ITEM 9 PART NO. 47020082
SPRING LOADED SHANK MOUNT COMPLETE (NO COULTER)

P.N. 47039417

SPRING BUNDLE ASSEMBLY COMPLETE
INCLUDES AT ITEMS (1 TO 25)
DOES NOT INCLUDE THE SHANK OR COULTER

ITEM	PART NO.	DESCRIPTION	QTY.
1	47029413	SPRING SHANK MOUNT ASSEMBLY	1
2	47019413	SHANK MOUNTING BASE	1
3	18901805	GREASE ZERK	2
4	47007766	BOLT, 3/4-10NC, X 1 3/4	1
5	18811800	FLAT WASHER, 3/4	2
6	47007085	END COLLAR	2
7	47007565	COMPRESSION SPRING	2
8	18446890	HEX. NUT, 3/4-10NC. GR. 5	2
9	47039413	SPRING LOADED SHANK MOUNT COMPLETE (NO COULTER)	1
		INCLUDES ITEMS 1 AND 10 TO 17	
10	18058429	BOLT, 3/4-10NC, X 1 3/4	1
11	18449003	HEX. JAM NUT, 3/4-10NC.	1
12	18058436	BOLT, 3/4-10NC, X 3	1
13	18891800	LOCKWASHER, 3/4	1
14	18418400	HEX. NUT, 3/4-10NC.	1
15	47007083	U-BOLT, 5/8-11NC. (4 X 6 BAR)	2
16	47009847	U-BOLT, 5/8-11NC. (6 X 6 BAR)	OR
17	18417900	LOCKWASHER, 5/8	4
18	47029417	COULTER MOUNTING BRACKET ASSEMBLY	4
		INCLUDES ITEM 19 TO 24	
19	47019417	COULTER MOUNTING BRACKET	1
20	18057426	BOLT, 1/2-13NC, X 1 1/2	4
21	18811400	FLATWASHER, 1/2	4
22	18891400	LOCKWASHER, 1/2	6
23	18417400	HEX. NUT, 1/2-13NC.	6
24	18057434	BOLT, 1/2-13NC, X 2 1/2	2
25	103471	SPRING SHANK (OR AS SPECIFIED)	1
26		COULTER ASSEMBLY COMPLETE	1
		REFER TO COULTER ILLUSTRATIONS (AG36 OR AG38)	
		FOR ITEM PART NUMBERS AND SPECIFY	
		BLADE ASSEMBLY NUMBER	
		AND SWIVEL BAR NUMBER.	

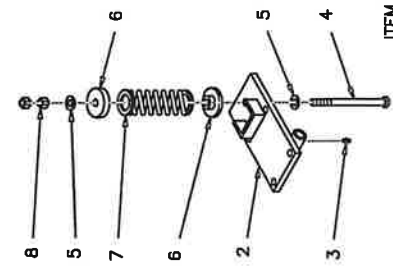

ITEM 1 (REPAIR PARTS)
SPRING SHANK MOUNT ASSEMBLY
INCLUDES ITEMS 2 TO 8

SPRING BUNDLE ASSEMBLY (FOR EDGE-BENT SHANK) 2014 & NEWER

HI-TRIP EDGE BENT SHANK ASSEMBLY

- (COMPLETE W/ SHANK P.N. 47953973 4" X 6" MOUNTING BRKT) [NO COULTER]
- (COMPLETE W/ SHANK P.N. 47983973 6" X 6" MOUNTING BRKT) [NO COULTER]

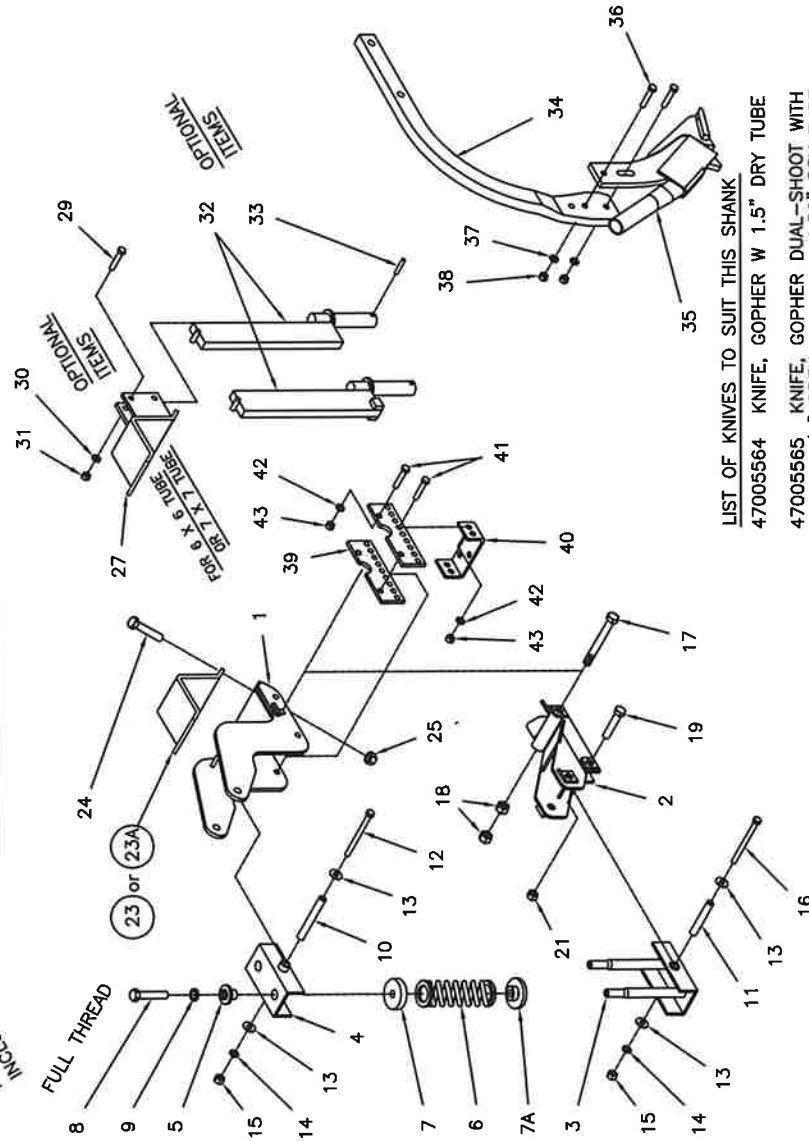
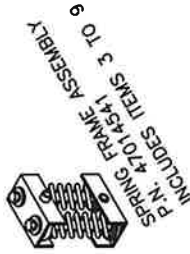
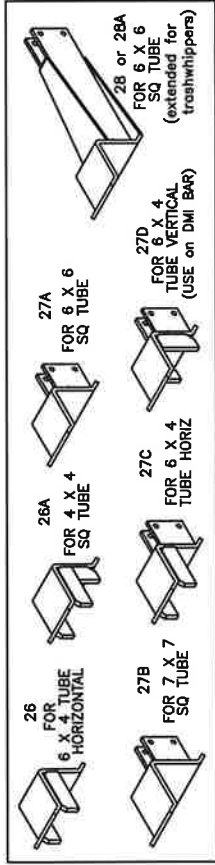

LIST OF KNIVES TO SUIT THIS SHANK

- 47005564 KNIFE, GOPHER W 1.5" DRY TUBE
- 47005565 KNIFE, GOPHER DUAL-SHOOT WITH 3/8" OPEN TUBE AND 1.50" DRY TUBE
- 47005857 KNIFE, MAG 50 DUAL-SHOOT WITH 3/8" OPEN TUBE AND 1.50" DRY TUBE

ITEM	PART NO.	DESCRIPTION	QTY
1	47013973	HI-TRIP SPRING BUNDLE COMPLETE	1
		INCLUDES ITEMS 1 TO 18 (PREASSEMBLED)	
2	47004530	MAIN BRACKET, (6 X 6 BAR)	OR
	47015003	MAIN BRACKET, (7 X 7 BAR)	1
3	47003973	SHANK PIVOT BRACKET (2014)	OR
	47014541	SPRING FRAME ASSEMBLY	1
		INCLUDES ITEMS 3 TO 9	
4	47004541	SPRING FRAME, BOTTOM	1
5	47004538	SPRING FRAME, TOP	1
6	47004544	SPRING RETAINER	2
7	47007565	COMPRESSION SPRING, 5/8 WIRE	2
8	47004549	SPRING CAP, TOP	2
9	47005330	SPRING CAP, BOTTOM	2
10	47004547	BOLT, 5/8-11NC, X 3 3/4 (SPECIAL)	2
11	18891600	LOCK WASHER, 5/8	2
12	47004551	INNER BUSHING, (TOP) 5 13/16	1
13	47004550	INNER BUSHING, (BOTTOM) 5 5/8	1
14	18057464	BOLT, 1/2-13NC, X 7	1
15	18891400	FLAT WASHER, 1/2	4
16	18891400	LOCK WASHER, 1/2	4
17	18417400	HEX. NUT, 1/2-13NC	2
18	18057462	BOLT, 1/2-13NC, X 6	1
19	18058422	BOLT, 3/4-10NC, X 7 1/2 GR. 5	1
20	18418400	HEX. NUT, 3/4-10NC	2
21	18058436	BOLT, HEX HD 3/4NC X 3 GR5 ZC	2
22	OMITTED		
23	18458400	NUT, CENTER LOCK 3/4NC ZC	2
24	47004532	SPRING BUNDLE CLAMP (6X6 BAR)	2
25	47015004	SPRING BUNDLE CLAMP (7X7 BAR)	OR
26	18098453	BOLT, 5/8-11NC, X 3 GR 8	4
27	18458451	TOP LOCK NUT, 5/8-11NC	4
28		ITEMS 26 TO 38 ARE CONSIDERED "OPTIONAL"	
29	47004555	SPRING BUNDLE CLAMP (6X4 HORIZ)	1
30	47004555	SPRING BUNDLE CLAMP (4X4 BAR)	1
31	47004553	CLAMP W/CLTR MOUNT (6X6 BAR)	1
32	47015005	CLAMP W/CLTR MOUNT (7X7 BAR)	1
33	47004557	CLAMP W/CLTR MOUNT (6X4 VERT)	1
34	47004557D	CLAMP 20*CLTR MNT (6X4 VERT)	1
35	47005894	CLAMP 20*CLTR MNT (trashwhipper)	1
36	47007894	CLAMP 24*CLTR MNT (trashwhipper)	1
37	18057434	BOLT, 1/2-13NC, X 2 1/2 GR5	2
38	18891400	LOCK WASHER, 1/2	2
39	18417400	HEX. NUT, 1/2-13NC	2
40	47303811	COULTER SWIVEL BAR (INCL ITEM 33)	1
41	47304522	COULTER SWIVEL BAR (SPECIAL)	1
42	18511032	SPRING PIN, 1/4 X 2 1/4 (STD)	1
43	OPTIONAL	COULTER BAR WITH RESTRICTED SWING 10 DEG. AND 15 DEG. AVAILABLE. PLEASE CALL AG SYSTEMS FOR INFO.	
		SEE AG37 GENERATION THREE COULTER ILLUSTRATION	
34	47003977	KNIFE SHANK, 1 1/4 THK EDGE-BENT 1 (2014 AND NEWER)	1
35	KNIFE, SEE LIST OF KNIVES LISTED ON LEFT		2
36	18057434	BOLT, 1/2 -13NC, X 2 1/2 GR5	2
37	18891400	LOCK WASHER, 1/2	2
38	18417400	HEX. NUT, 1/2-13NC	2
39	47995891	TRASHWHIPPER MOUNT KIT (ITEMS 39-43)	2
40	47005891	PLATE, TRASHWHIPPER MOUNTING	1
41	47005892	MOUNT, CHANNEL, TRASHWHIPPER	1
42	18057147	BOLT, 7/16NC X 1 1/2 GR5 ZC	8
43	18891300	LOCKWASHER, 7/16 ZC	8
	18437100	NUT, HEX 7/16NC ZC	8
		(with optional coulters order option item 28)	

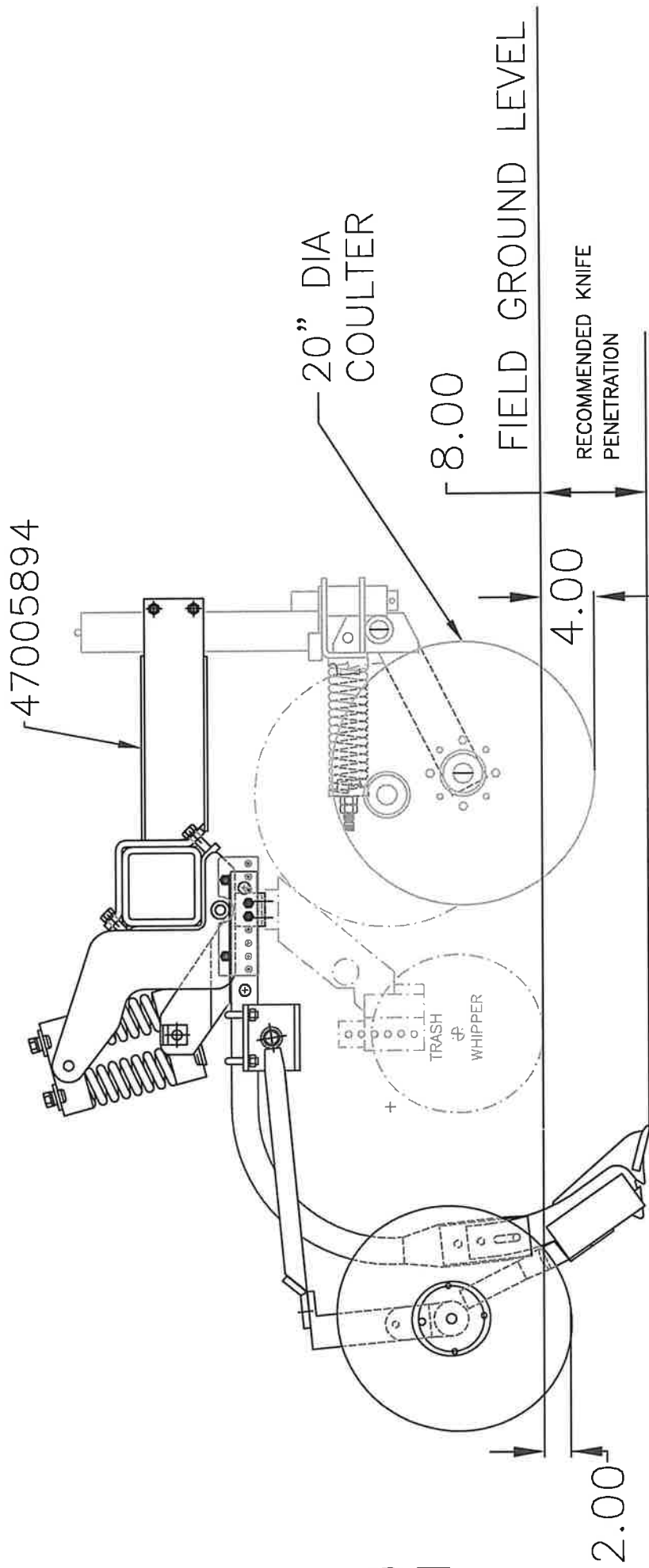

HIGH-TRIP SPRING BUNDLE 2014
47005564 KNIFE WITH EDGE-BENT SHANK
SHOWN WITH TRASHWHIPPER OPTION,
EXTENDED COULTER BRACKET OPTION,
AND OPTIONAL FLOATING ARM DISC COVERS

47007894

(use with 24" coulters)

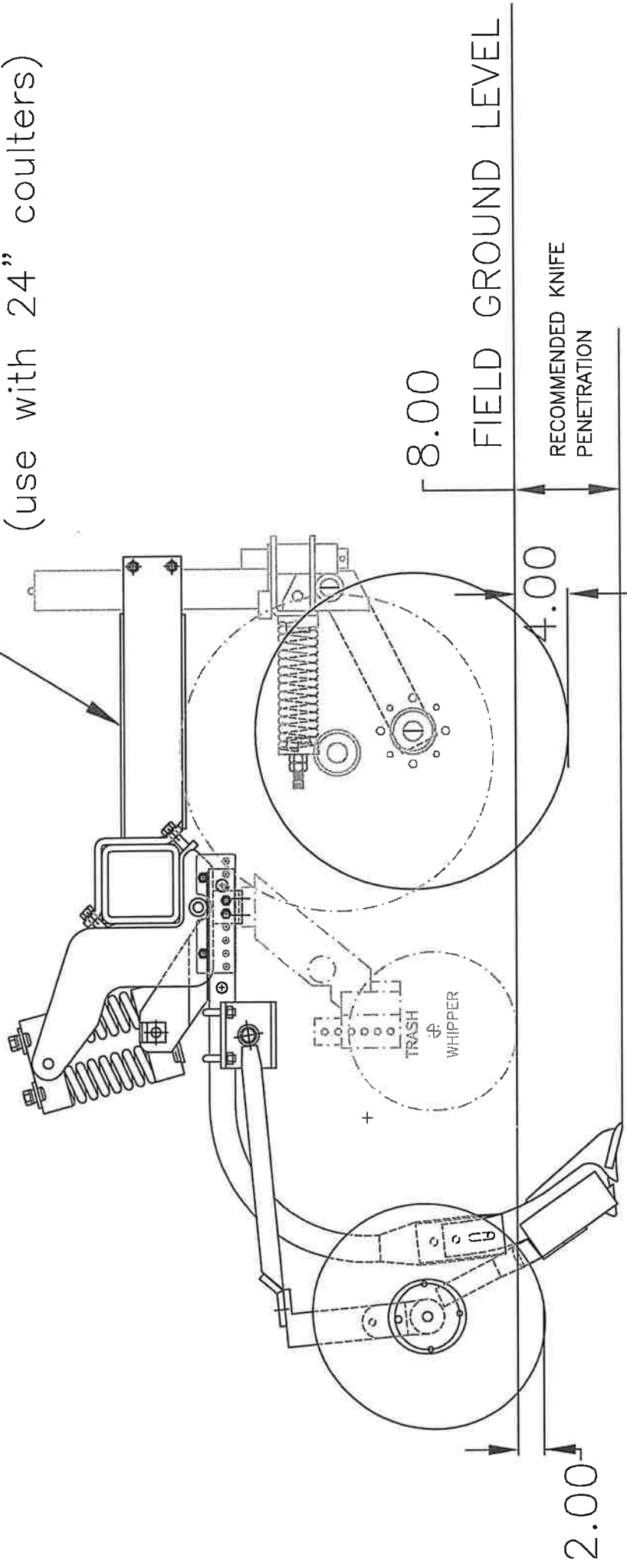

HIGH-TRIP SPRING BUNDLE 2014

47005564 KNIFE WITH EDGE-BENT SHANK
SHOWN WITH TRASHWHIPPER OPTION,
EXTENDED COULTER BRACKET OPTION,
AND OPTIONAL FLOATING ARM DISC COVERS

AG37 COULTER ASSEMBLY
 (GENERATION II)
 MAINTENANCE-FREE HUB
 FROM 2001 TO PRESENT

AG37GN2
 REV/ 10-22-09

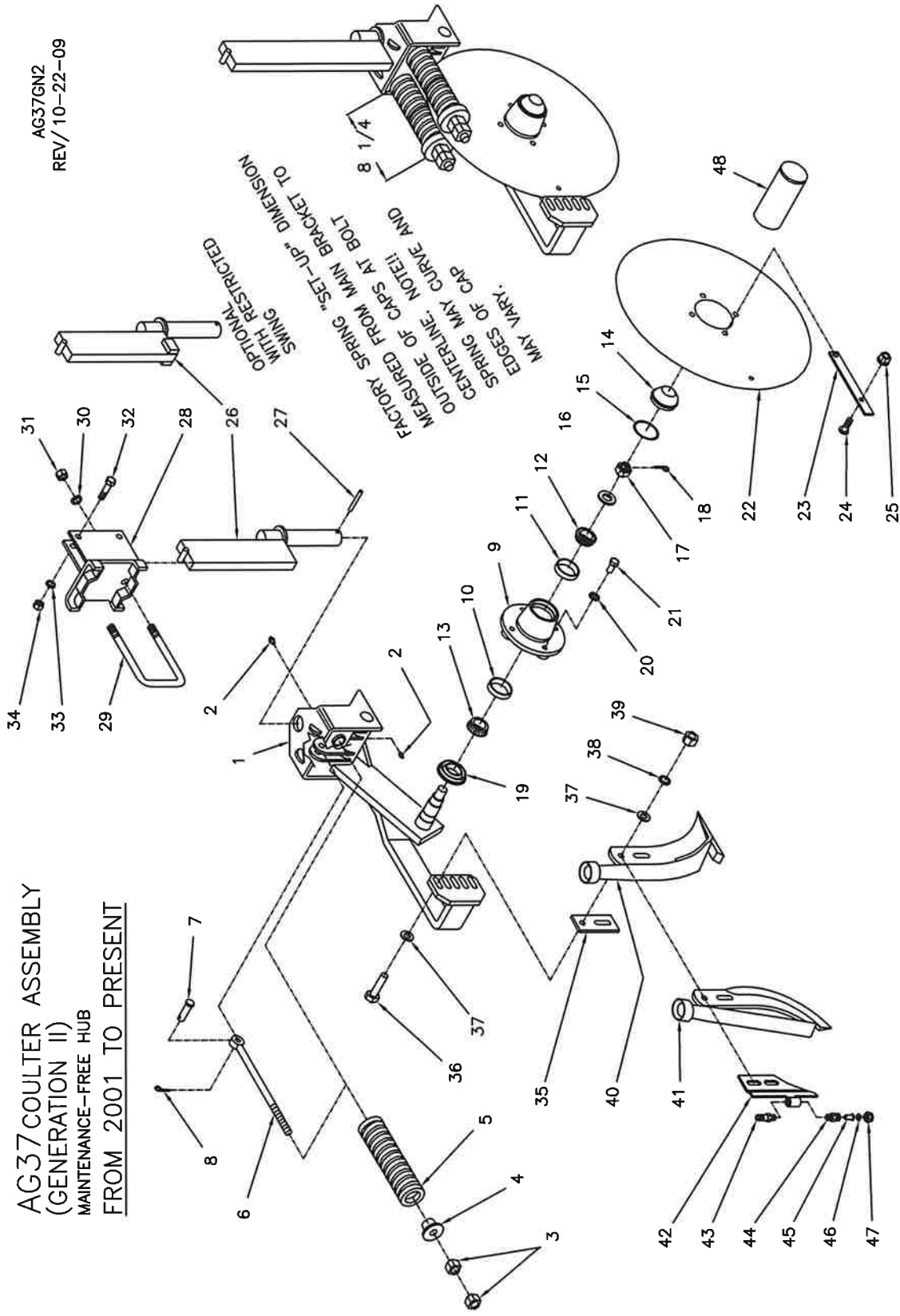

AG37 COULTER ASSEMBLY (GENERATION II)

AG37GN2LS
REV. 01/28/22

with MAINTENANCE-FREE HUB MOUNTING INSTRUCTIONS AND PARTS LIST

1. Your AG37 main bracket and hub are pre-assembled at the factory and the trip springs are pre-loaded to provide 525 pounds blade pressure. This should be adequate for normal field conditions. The coulters should trip up only when hitting a solid obstruction. During your field operation check to make sure the coulters are staying rigid most of the time. Excessive flexing will cause premature spring failure. If repeated tripping is occurring, tighten the spring tension till rigid normal operation is achieved.
2. Assemble the blade (item 22) to the hub, and (if used) the scraper (item 23) to the blade with the hardware (item 24 and item 25).
3. Assemble the swivel bar (item 26) to the main bracket (item 1). Be sure the 1 x 3 bar is positioned between the half moon stops on top of the main bracket. Install the roll pin (item 27).
4. Position the mounting brackets (item 28) at the desired spacing and fasten with the U-bolts (item 29) and hardware (items 30 and 31).
5. Install the coulters assemblies to the mounting brackets (item 28) and fasten with the bolts (item 32) and hardware (items 33 and 34).
6. Assemble the hardware snug only.
6. Adjust the coulters blade to the desired depth and tighten the hardware securely.
7. Assemble the knife (item 40 or 41) to the coulters assembly with the shims (item 35), bolts (item 36) and hardware (items 37, 38 and 39). Select and install the shims in a manner so that as you rotate the blade a complete revolution you observe that the point of the knife and the lower area of the knife is behind the blade at all times. The knife should also be set at zero clearance (see step 7). This will maintain the blade's trash cutting ability. The top of the knife should be away from the blade far enough so that the scraper can pass the top, thick part of the knife without rubbing the knife. NOTE: The bolt head should be located next to the bracket (see illustration) and any shims not needed should be placed between the backside of the bracket and the flatwasher next to the head of the bolt.
8. Adjust the knife position relative to the blade edge. The backswept knife (item 41) should be positioned to obtain maximum backsweep. Locate the upper bolt to the front of the slot and the lower bolt to the back of the slot. The forward swept knife (item 40) should be positioned as close to the blade edge as possible. Rotate the coulters blade to determine the point of maximum eccentric runout of the circumference and adjust the knife to zero clearance at this point. NOTE: The knife will have to be re-adjusted regularly.
9. Make sure all hardware is tightened securely.
10. During field operation grease the swivel bar journals weekly. And grease for end-of-season storage. Inspect the coulters blade and knife clearance daily. Adjust per step 8 if required. The coulters hub is greased-for-life and should need no regular maintenance. Check for damage to the dust cap and grease seal daily.

ITEM	PART NO.	DESCRIPTION	QTY	ITEM	PART NO.	DESCRIPTION	QTY
1	47309570	MAIN BRKT. & BLADE ASSEMBLY, L.H.	1	30	18891600	LOCKWASHER, 5/8	2
2	47309705	MAIN BRKT. & BLADE ASSEMBLY, R.H. OPT.	1	31	18417900	HEX. NUT, 5/8-11NC.	2
3	47108570	INCLUDES ITEMS 1 TO 22	1	32	18057434	BOLT, 1/2-13NC. X 2 1/2	2
4	47109568	MAIN BRKT W/HUB ASSEMBLY, L.H.	1	33	18891400	LOCKWASHER, 1/2	2
5	47309570	MAIN BRKT W/HUB ASSEMBLY, R.H. OPT.	1	34	18417400	HEX. NUT, 1/2-13NC.	2
6	47301524	INCLUDES ITEMS 1 TO 21 (W/O BLADE)	1	35	47306661	SHIM, 1/4	1
7	18901805	MAIN BRACKET, L.H. (W/O HUB OR BLADE)	1	36	47308662	SHIM, 1/8	1
8	18560722	MAIN BRACKET, R.H. (W/O HUB OR BLADE) OPT.	1	37	47308663	SHIM, 1/16	1
9	47300351	GREASE ZERK, STRAIGHT	2	38	18057432	BOLT, 1/2-13NC. X 2 1/4	2
10	47301547	HEX. NUT, 5/8-11NC.	4	39	18891400	LOCKWASHER, 1/2	2
11	47300352	SPRING CAP	2	40	18417400	HEX. NUT, 1/2-13NC	2
12	47301547	COMPRESSION SPRING	2	41	47309735	DRY. KNIFE, W/BUSHING, (FORWARD)	1
13	18541428	EYE BOLT, SPRING RETAINER	2	42	47309734	DRY. KNIFE, W/O BUSHING, (FORWARD)	1
14	47300350	CLEVIS PIN, 1/2 X 1 3/4	2	43	47309742	LIQUID KNIFE, (FORWARD)	1
15	47300350	COTTER PIN, 5/32 X 1	2	44	47007468	LIQUID KNIFE, (FORWARD) S.S. TUBE	1
16	47300351	HUB COMPLETE (W/O SEAL & BOLTS)	1	45	47309748	DRY. KNIFE, W/BUSHING, (BACKSWEPT)	1
17	47300351	INCLUDES ITEMS 9 TO 15	1	46	47309759	DRY. KNIFE, W/O BUSHING, (BACKSWEPT)	1
18	47005510	HUB WITH CUPS, ITEMS 10 & 11	1	47	47309750	LIQUID KNIFE, (BACKSWEPT)	1
19	47005048	BEARING CUP, INNER	1	48	47005500	DUST CAP INSTALLATION TOOL (OPTIONAL)	1
20	47005548	BEARING CUP, OUTER	1				
21	47005513	BEARING CONE, INNER	1				
22	47005513	BEARING CONE, OUTER	1				
23	47005513	DUST CAP	1				
24	4790351	O-RING DUST SEAL	1				
25	47300352	SPINDLE WASHER	1				
26	47300353	SLOTTED NUT, 7/8-14UNF	1				
27	18560726	COTTER PIN, 5/32 X 1 1/2	1				
28	40030326	GREASE SEAL	1				
29	18891400	LOCK WASHER, 1/2 I.D.	4				
30	18057522	WHEEL BOLT, 1/2-20NF X 1	4				
31	47305027	COULTER BLADE, 20" RIPPLED	1				

REF 47300300 SPINDLE ONLY

AG38 COULTER ASSEMBLY

GENERATION II
 WITH MAINTENANCE--FREE HUB
 FROM 2001 TO PRESENT

AG38GN2
 REV 10-22-09

FOR 6 X 6 FRAME TUBE
 (3) REQ'D. OF
 ITEMS 29, 30, & 31
 FOR EACH BRACKET

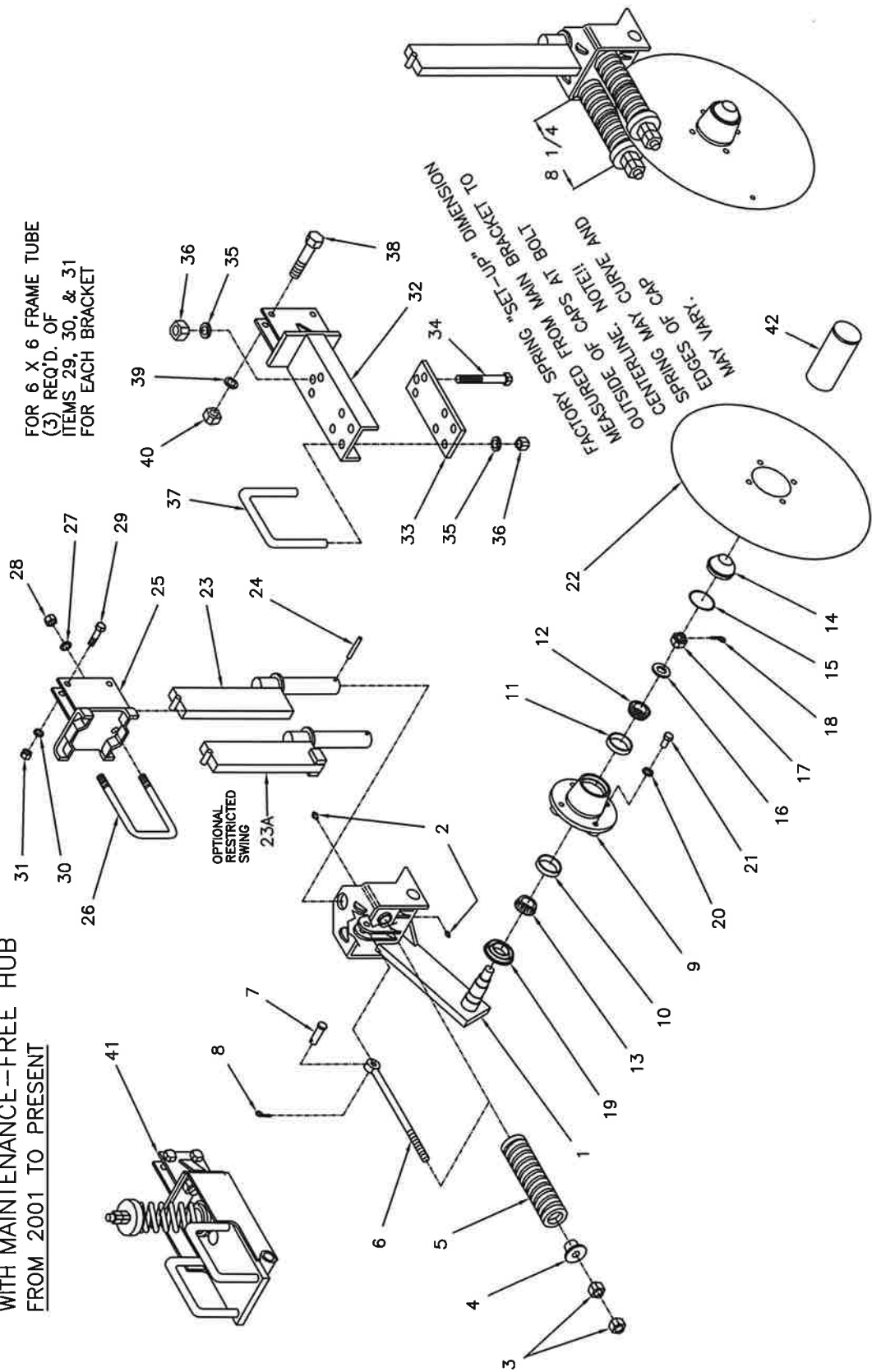

FACTORY SPRING "SET-UP" DIMENSION
 MEASURED FROM MAIN BRACKET TO
 CENTERLINE OF CAPS AT BOLT
 1/4" 8
 SPRING MAY CURVE AND
 EDGES OF CAP CURVE AND
 MAY VARY.

AG38 COULTER ASSEMBLY (GENERATION II)
with MAINTENANCE-FREE HUB
MOUNTING INSTRUCTIONS AND PARTS LIST

AG38GN2LS
REV.01/28/22

- Your AG38 main bracket and hub are pre-assembled at the factory, and the trip springs are pre-loaded to provide 525 pounds blade pressure. This should be adequate for normal field conditions. The coultter arm should trip up only when hitting a solid obstruction. During your field operation check to make sure the coultter arm is staying rigid most of the time. Excessive flexing will cause premature spring failure. If repeated tripping is occurring tighten the spring tension till rigid operation is achieved.
- Assemble the blade (item 22) to the hub.
- Assemble the swivel bar (item 23) to the main bracket (item 1). Make sure that the 1 x 3 flat bar is positioned between the half moon stops on top of the main bracket. Install the roll pin (item 24).
- Position the mounting brackets (item 25) at the desired spacing and fasten with the u-bolts (item 26) and hardware (item 27 and item 28).
- Install the coultter assemblies to the mounting brackets (item 25) and fasten with the bolts (item 29) and hardware (item 30 and item 31). Assemble the hardware snug only.
- Adjust the coultter blade to the desired depth and tighten the hardware securely.
- Make sure "all" hardware is tightened securely.
- During field operation grease the swivel bar journals weekly. And grease for end-of-season storage. The coultter hub is greased-for-life and should need no regular maintenance. Check for damage to the dust cap and grease seal daily.

31

ITEM	PART NO.	DESCRIPTION	QTY	ITEM	PART NO.	DESCRIPTION	QTY	ITEM	PART NO.	DESCRIPTION	QTY
1	47308805	MAIN BRACKET & BLADE ASSEMBLY	1	24	18511032	ROLL PIN, 1/4 X 2 1/4	1	31	18417400	HEX. NUT, 1/2-13NC.	2
2	47109572	INCLUDES ITEMS 1 TO 22	1	25	47009887	MOUNTING BRACKET, (4" VERTICAL)	1	32	47309370	UNIV MT BRKT FOR 1 X 2 COMP. OPTION	1
3	47309572	MAIN BRKT. W/HUB ASSEMBLY	1	26	47008951	U-BOLT, 5/8-11NC. (4" V X 6" H BAR)	1	33	47006832	ON 4 X 6 OR 4 X 4 TOOLBARS.	1
4	18901805	INCLUDES ITEMS 1 TO 21 (W/O BLADE)	1	28	44001616	U-BOLT, 5/8-11NC. (4" V X 4" H BAR)	1	34	18057938	UNIV MT BRKT FOR 1 1/4 COMP. OPTION	1
5	18407900	MAIN BRACKET	2	25	OTHER MOUNTING BRACKET OPTIONS		2	35	47994604	ON 4 X 6 OR 4 X 4 TOOLBARS.	1
6	47301530	GREASE ZERK, STRAIGHT	4	26	47008659	MOUNTING BRACKET, (2 1/2" VERTICAL)	1	36		ALL ITEMS IDENTICAL EXCEPT ITEM 37	37
7	47301524	HEX. NUT, 5/8-11NC.	2	25	47309907	U-BOLT, 5/8-11NC. (3" VERT., EXT.)	1	37		INCLUDE ITEMS 32 TO 40	37
8	47301547	SPRING CAP	4	26	47308677	MOUNTING BRKT., (3" VERT., STD.)	1	38	47006950	SHANK HOLDER, (1 X 2 KNIFE SHANK)	1
9	18541428	COMPRESSION SPRING	2	26	47008987	MOUNTING BRACKET, (6" VERTICAL)	1	39	18057434	CLAMP PLATE	1
10	18560722	EYE BOLT, SPRING RETAINER	2	25	47009847	U-BOLT, 5/8-11NC. (6" V X 4" H BAR)	1	40	18417400	BOLT, 1/2-13NC. X 2 1/2	2
11	47300350	CLEVIS PIN, 1/2 X 1 3/4	2	26	47308736	U-BOLT, 5/8-11NC. (7" VERTICAL)	1	41		SEE SEPARATE ILLUSTRATION FOR SPRING BUNDLE PARTS	2
12	47300350	COTTER PIN, 5/32 X 1	2	26	47302730	U-BOLT, 1/2-13NC. (7" V X 7" H BAR)	1	OR	47009661	SPRING BUNDLE COMPLETE (1 SPRING) OPT.	2
13	47300350	HUB COMPLETE (W/O SEAL & BOLTS)	1	27	NOTE FOR 7"	U-BOLT USE 1/2-13NC. HEX. NUTS	2	WITH	47029417	SPRING BUNDLE COMPLETE (2 SPRINGS)	2
14	47300351	INCLUDES ITEMS 9 TO 15	1	28	18891600	LOCKWASHER, 5/8	2			COULTER MOUNTING BRKT. COMPLETE	2
15	47300351	HUB WITH CUPS ITEMS 10 & 11	1	29	18417900	HEX. NUT, 5/8-11NC.	2	42	47005500	DUST CAP INSTALLATION TOOL (OPTIONAL)	1
16	47005510	BEARING CUP, INNER	1	30	18057434	BOLT, 1/2-13NC. X 2 1/2	2				
17	47005510	BEARING CUP, OUTER	1		18891400	LOCKWASHER, 1/2	2				
18	47005048	BEARING CONE, OUTER	1								
19	47005548	BEARING CONE, INNER	1								
20	47005513	DUST CAP	1								
21	47980351	O-RING DUST SEAL	1								
22	47300353	SPINDLE WASHER	1								
23	18560724	SLOTTED NUT, 7/8-14UNF.	1								
24	40030326	COTTER PIN, 5/32 X 1 1/4	1								
25	18891400	GREASE SEAL	4								
26	18057522	WHEEL BOLT, 1/2-20NF. X 1	4								
27	47305027	COULTER BLADE, 20" RIPPLED	1								
28	47303811	COULTER SWIVEL BAR, 18" (INCL ITEM 24)	1								
29	47309811	COULTER SWIVEL BAR, 12" (INCL ITEM 24)	1								
30	OPTIONAL	COULTER BAR W/RESTRICTED SWING	1/OPT								
31	OPTIONAL	10 DEG. AND 15 DEG. AVAILABLE	1/OPT								
32	47005147	18" BAR 10" LH RESTRICTED SWING	1								
33	47005147R	18" BAR 10" RH RESTRICTED SWING	1								
34	47005149	18" BAR 15" RESTR. SWING (BOTH WAYS)	1								
35	47005149L	18" BAR 15" LH RESTRICTED SWING	1								
36	47005149R	18" BAR 15" RH RESTRICTED SWING	1								
37		CALL AG SYSTEMS FOR INFO.									

REF 47300300 SPINDLE ONLY

AG37GN3
REV. 12-15-11

AG37 COULTER ASSEMBLY
(GENERATION III)
MAINTENANCE-FREE HUB AND JOURNALS
FROM 2003 TO PRESENT

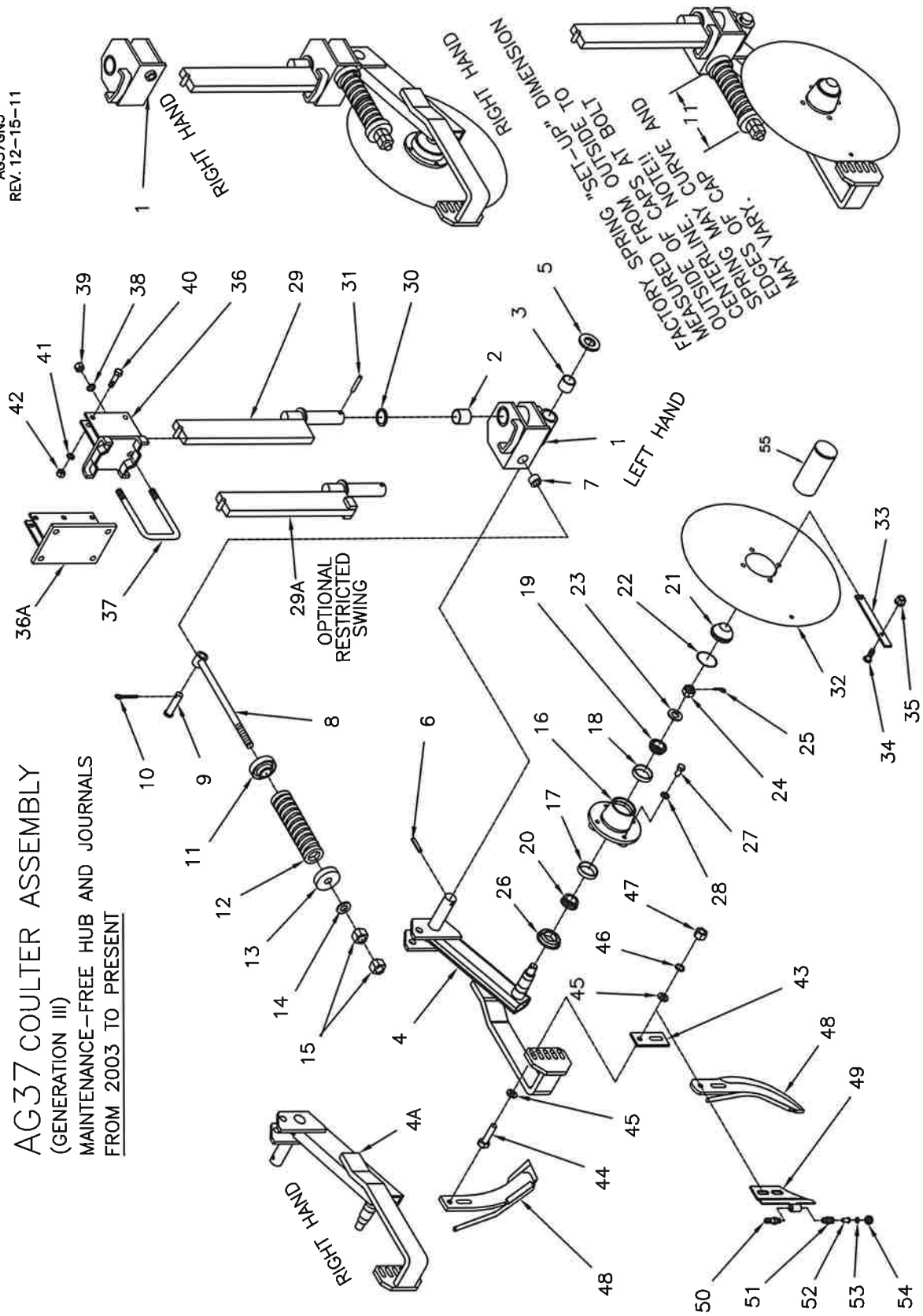

AG37 COULTER ASSEMBLY (GENERATION III)

AG37GN3LS
REV. 01/28/22

MAINTENANCE-FREE HUB AND JOURNALS MOUNTING INSTRUCTIONS AND PARTS LIST

1. Your AG37 Gen III main bracket and hub are pre-assembled at the factory and the trip spring is preloaded to provide 600 pounds blade pressure. This should be adequate for normal field conditions. The coultter arm should trip up only when hitting a solid obstruction. During your field operation check to make sure the coultter arm is staying rigid most of the time. Excessive flexing will cause premature spring failure. If repeated tripping is occurring, tighten the spring tension till rigid normal operation is achieved.

2. Assemble the blade (item 32) to the hub, and (if used) the scraper (item 33) to the blade with the hardware (items 34 & 35).

3. Assemble the swivel bar (item 29) to the bracket assembly. Be sure the swivel bar is positioned between the swivel control lugs on top of the main bracket. Install the washer (item 30) and pin (item 31).

4. Position the mounting bracket (item 36) at the desired spacing and fasten with the u-bolt (item 37) and hardware (items 38 and 39).

5. Install the coultter assemblies in the mounting brackets (item 36) and fasten with the bolts (item 40) and hardware (items 41 and 42). Assemble the hardware snug only.

6. Adjust the coultter blade to the desired depth and tighten the hardware securely.

7. Assemble the knife (item 48) to the coultter assembly with the shims (item 43), bolts (item 44) and hardware (items 45, 46 and 47). Select and install the shims in a manner so that as you rotate the blade a complete revolution you see that the point of the knife and the lower area of the knife is behind the blade at all times. The backset knife should be positioned to obtain maximum backswep. Locate the upper bolt to the front of the slot and the lower bolt to the back of the slot. Note, the bolt head should be located next to the bracket (see illustration) and any shims not needed should be placed between the back side of the bracket and the flat washer next to the head of the bolt.

8. The front swept knife should be positioned as close to the blade edge as possible. Zero clearance. This will maintain the blade's trash cutting ability. Rotate the coultter blade to determine the point of maximum eccentric runout of the circumference and adjust the knife to zero clearance at this point. The top of the knife should be away from the blade far enough so that the scraper can pass the top, thick part, of the knife without rubbing the knife. NOTE: The knife position should be inspected frequently and re-adjusted regularly.

9. Make sure all hardware is tightened securely.

10. No field operation lubricating is required. The hubs are sealed and greased for life. The swivel journals are assembled with grease-less bushings. For repair procedure, see separate sheet titled PROCEDURE TO SERVICE A COULTER HUB.

REF 47300300 SPINDLE ONLY

ITEM	PART NO.	DESCRIPTION	QTY	ITEM	PART NO.	DESCRIPTION	QTY	ITEM	PART NO.	DESCRIPTION	QTY
1	40350000	MAIN BRKT. & BLADE, L.H. (STANDARD)	1	37	47010154	U-BOLT, 5/8-11NC. (6" X 4" H BAR)	1	37	47010154	U-BOLT, 5/8-11NC. (6" X 4" H BAR)	1
2	40351000	INCLUDES ITEMS 1 TO 32	OPT.	20	47005513	DUST CAP	1	47009847	47009847	U-BOLT, 5/8-11NC. (6" X 6" H BAR)	1
3	47304500	MAIN BRKT. W/HUB, RIGHT HAND	OPT.	22	47900351	O-RING DUST SEAL	1	36A	47309736	MOUNTING BRACKET, (7" VERTICAL)	2
4	47004500	INCLUDES ITEMS 1 TO 31 (W/O BLADE)	OPT.	23	47300352	SPINDLE WASHER	1	37	47302730	U-BOLT, 1/2-13NC. (7" X 7" H BAR)	4
5	47014500	HOUSING W/BUSHINGS, L.H. (STD)	1	24	47300353	SPOTTED NUT, 7/8-14UNF	1	38	18891400	LOCKWASHER, 1/2"	4
6	47009984	HOUSING W/BUSHINGS, RIGHT HAND	OPT.	25	18560726	COTTER PIN, 5/32 X 1 1/2	1	39	18417400	HEX. NUT, 1/2-13NC	4
7	47009953	PIVOT BUSHING, 1 1/2 I.D.	2	26	40030326	GREASE SEAL	1	38	18891600	LOCKWASHER, 5/8	2
8	47004507	PIVOT ARM, L.H. FRONT SWEEP KNIFE	1	27	18057522	WHEEL BOLT, 1/2-20NF X 1	4	39	18417900	HEX. NUT, 5/8-11NC.	2
9	47014507	PIVOT ARM, R.H. FRONT SWEEP KNIFE	OPT.	28	18891400	LOCK WASHER, 1/2 I.D.	4	40	18057434	BOLT, 1/2-13NC. X 2 1/2	2
10	18300326	RETAINING WASHER, 1 3/8 I.D.	1	29	47304522	COULTER BAR W/RESTRICTED SWING	1	41	18891400	LOCKWASHER, 1/2"	2
11	18511035	EXPANSION PIN, 3/8 X 2	1	29A	OPTIONAL	10 DEG. AND 15 DEG. AVAILABLE	1	42	18417400	HEX. NUT, 1/2-13NC.	2
12	2-6666	EYE BOLT GUIDE	1	47005144	47005144	18" BAR 10' RESTR. SWING (BOTH WAYS)	1	43	ITEMS 40, 41 & 42 (3)	REQ'D. W 6 X 6 OR 7 X 7 TUBE	1
13	47004518	EYE BOLT, SPRING RETAINER	1	47005144R	47005144R	18" BAR 10' RESTR. SWING LH ONLY	1	43	47306661	SHIM, 1/4"	1
14	18541835	CLEVIS PIN, 3/4 X 2 1/2	1	47005145	47005145	18" BAR 15' RESTR. SWING RH ONLY	1	44	47306662	SHIM, 1/16	1
15	18560726	SPRING CAP WITH COUNTER-BORE	1	47005145L	47005145L	18" BAR 15' RESTR. SWING LH ONLY	1	45	18057432	BOLT, 1/2-13NC. X 2 1/4	2
16	47004521	COMPRESSION SPRING	1	47005145R	47005145R	18" BAR 15' RESTR. SWING RH ONLY	1	46	18811400	FLATWASHER, 1/2"	2
17	47007565	SPRING CAP, STANDARD CASTING	1			CALL AG SYSTEMS FOR INFO.	1	47	18891400	LOCKWASHER, 1/2"	2
18	47007085	FLAT WASHER, 3/4	1	30	18300323	RETAINING WASHER, 1 1/2 I.D.	1	48	18417400	HEX. NUT, 1/2-13NC	2
19	18651800	HUB COMPLETE (W/O SEAL & BOLTS)	1	31	18511036	EXPANSION PIN, 3/8 X 2 1/4	1	48	47309756	LIQUID KNIFE, (FRONTSWEPT)	OPT.
20	18446890	HUB WITH ITEMS 16 TO 22	1	32	47305027	COULTER BLADE, 20" RIPPLED	1	49	47307466	LIQUID KNIFE, (FRONTSWEPT)	OPT.
21	47300350	INCLUDES ITEMS 17 & 18	1	ITEMS 33 TO 35	ITEMS 33 TO 35	OPT. USE W/FRONT SWEEP KNIFE ONLY	1	49A	47309038	NOZZLE BRACKET (L.H.) (STANDARD)	OPT.
22	47300351	BEARING CUP, INNER	1	33	47306921	SCRAPER	1	50	47997038	NOZZLE BRACKET (R.H.)	OPT.
23	47005010	BEARING CUP, OUTER	1	34	18033810	HUB, 3/8-16NC. X 1, TRUSS HEAD	1	51	100859	HOSEBARB, S.S. 1/4 NPT. X 1/2 TUBE	1
24	47005048	BEARING CONE, OUTER	1	35	18496800	HEX. NUT, 3/8-16NC. FLANGED	1	52	504015	STREAM STABILIZER	1
25				36	47309893	MOUNTING BRACKET, (4" VERTICAL) STD.	1	53	ORFICE	SELECT FROM ORFICE CHART	1
26				37	44001615	U-BOLT, 5/8-11NC. (4" X 4" H BAR)	1	54	503127	CAP	1
27				36	47309888	MOUNTING BRACKET, (6" VERTICAL)	1	55	47005500	DUST CAP INSTALLATION TOOL (OPTIONAL)	1

AG38 COULTER ASSEMBLY
 (GENERATION III)
 MAINTENANCE-FREE HUB AND JOURNALS
 FROM 2003 TO PRESENT

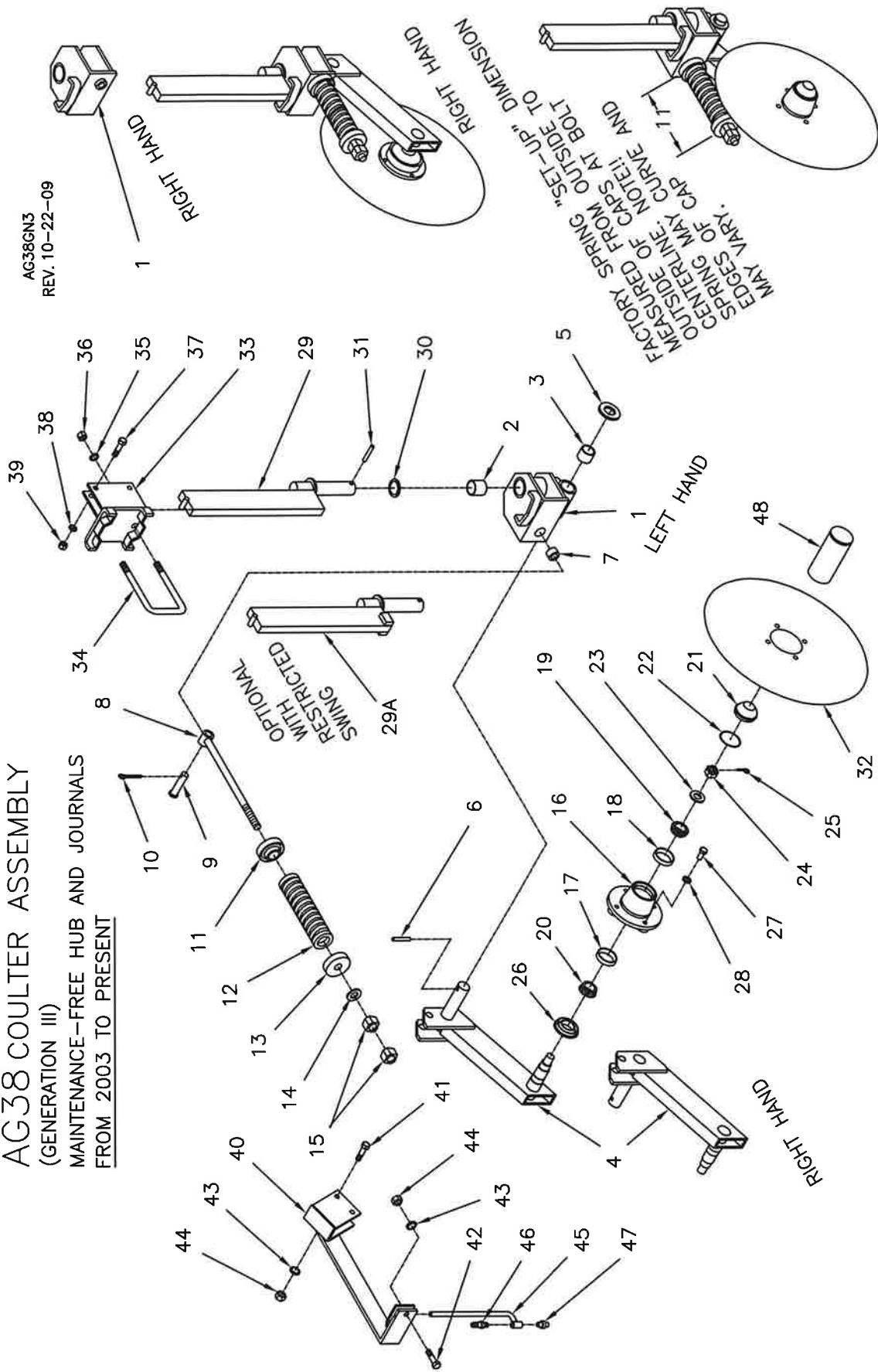

AG38 COULTER ASSEMBLY (GENERATION III)

AG38GN3LS
REV. 01/28/22

with MAINTENANCE—FREE HUB
MOUNTING INSTRUCTIONS AND PARTS LIST

- 1. Your AG38 main bracket and hub are pre-assembled at the factory, and the trip springs are pre-loaded to provide 600 pounds blade pressure. This should be adequate for normal field conditions. The coulters arms should trip up only when hitting a solid obstruction. During your field operation check to make sure the coulters arm is staying rigid most of the time. Excessive flexing will cause premature spring failure. If repeated tripping is occurring tighten the spring tension till rigid operation is achieved.
- 2. Assemble the blade (item 32) to the hub.
- 3. Assemble the swivel bar (item 29) to the main bracket (item 1). Make sure that the 1 x 3 flat bar is positioned between the u-bracket stop on top of the main bracket. Install the washer (item 30) and roll pin (item 31).
- 4. Position the mounting brackets (item 33) at the desired spacing and fasten with the u-bolts (item 34) and hardware (item 35 and item 36).
- 5. Install the coulters assemblies to the mounting brackets (item 33) and fasten with the bolts (item 37) and hardware (item 38 and item 39). Assemble the hardware snug only.
- 6. Adjust the coulters blade to the desired depth and tighten the hardware securely.
- 7. Make sure "all" hardware is tightened securely.
- 8. No field operation lubrication is required. The hubs are sealed and greased for life. The swivel journals are assembled with grease-less bushings. For repair procedure, see separate sheet titled PROCEDURE TO SERVICE A COULTER HUB.

ITEM	PART NO.	DESCRIPTION	QTY	ITEM	PART NO.	DESCRIPTION	QTY	ITEM	PART NO.	DESCRIPTION	QTY
1	40350001	MAIN BRKT. & BLADE, L.H. (STANDARD)	1	21	47005513	DUST CAP	1	37	18057434	BOLT, 1/2-13NC. X 2 1/2	2
2	40351011	INCLUDES ITEMS 1 TO 32	OPT	22	47990351	O-RING DUST SEAL	1	38	18891400	LOCKWASHER, 1/2	2
3	47304508	MAIN BRKT. W/HUB, L.H. (STANDARD)	1	23	47300352	SPINDLE WASHER	1	39	18417400	HEX. NUT, 1/2-13NC.	2
4	47014500	HOUSING W/BUSHINGS, L.H. (STD.)	1	24	47300353	SLOTTED NUT, 7/8-14UNF	1	ITEMS 37, 38, & 39, (3) REQ'D. WITH (6" BAR, VERT.)			
5	47009954	PIVOT BUSHING, 1 1/2 I.D.	2	25	18560726	COULTER PIN, 5/32 X 1 1/2	1	47995062	HI-PRESSURE NOZZLE BRKT. COMPLETE		1
6	47014508	PIVOT ARM, L.H. STANDARD	1	26	40030326	GREASE SEAL	1		INCLUDES ITEMS 40 TO 45		45
7	18511035	RETAINING WASHER, 3/8 X 2	1	27	18037522	WHEEL BOLT, 1/2-20NF. X 1	4	40	47015062	MOUNTING BRACKET	2
8	2-6666	EYE BOLT GUIDE	1	28	18891400	LOCK WASHER, 1/2	4	41	18057434	BOLT, 1/2-13NC. X 2 1/2	2
9	47004518	EYE BOLT, SPRING RETAINER	1	29	47304522	COULTER SWIVEL BAR, 18"	1	42	18057430	BOLT, 1/2-13NC. X 2	2
10	18541835	CLEVIS PIN, 3/4 X 2 1/2	1	29A	OPTIONAL	COULTER BARS W/RESTRICTED SWING	1	43	18891400	LOCK WASHER, 1/2	3
11	47004521	SPRING CAP, WITH COUNTER-BORE	1		47005144	18" BAR 10" RESTR. SWING BOTH WAYS	2	44	18417400	HEX. NUT, 1/2-13NC.	3
12	47007565	COMPRESSION SPRING	1		47005144	18" BAR 10" RESTR. SWING LH ONLY	1	45	47008501	NOZZLE BAR	1
13	47007085	SPRING CAP, STANDARD CASTING	1		47005145	18" BAR 15" RESTR. SWING RH ONLY	1	46	100859	HOSEBAR, 1/4P X 1/2T	1
14	18851800	FLAT WASHER, 3/4	2		47005145L	18" BAR 15" RESTR. SWING LH ONLY	1	47	504017	NOZZLE BODY ASSEMBLY	1
15	18446890	HEX. NUT, 3/4-10NC.	1		47005145R	18" BAR 15" RESTR. SWING RH ONLY	1		(ORIFICE DISK VARIES) SEE AG 37 ILLUSTRATION		
16	47300350	HUB COMPLETE (W/O SEAL & BOLTS)	1	30	18300323	CALL AG SYSTEMS FOR INFO.	1	48	47005500	DUST CAP INSTALLATION TOOL (OPTIONAL)	1
17	47300351	INCLUDES ITEMS 16 TO 22	1	31	18511036	RETAINING WASHER, 1 1/2 I.D.	1				
18	47005510	HUB WITH CUPS ITEMS 17 & 18	1	31	47305027	EXPANSION PIN, 3/8 X 2 1/4	1				
19	47005010	BEARING CUP, INNER	1	32	47309893	COULTER BLADE, 20" RIPPLED	1				
20	47005048	BEARING CUP, OUTER	1	33	47009891	MOUNTING BRACKET, (4" VERTICAL) STD.	1				
		BEARING CONE, OUTER	1	33	47006951	U-BOLT, 5/8-11NC. (4"V X 6"HORIZ BAR)	1				
		BEARING CONE, INNER	1	34	44001816	U-BOLT, 5/8-11NC. (4"V X 4"HORIZ BAR)	1				
			1		47309888	MOUNTING BRACKET, (6" VERTICAL)	2				
			1		47101054	U-BOLT, 5/8-11NC. (6"V X 4"HORIZ BAR)	2				
			1	35	47009847	U-BOLT, 5/8-11NC. (6"V X 6"HORIZ BAR)	2				
			1	36	18891600	LOCKWASHER, 5/8	2				
			1		18417900	HEX. NUT, 5/8-11NC.	2				

REF 47300300 SPINDLE ONLY

AG38 24 INCH COULTER ASSEMBLY

(GENERATION III)

MAINTENANCE-FREE HUB AND JOURNALS
FROM 2014 TO PRESENT

AG38GN324IN
02-11-2015

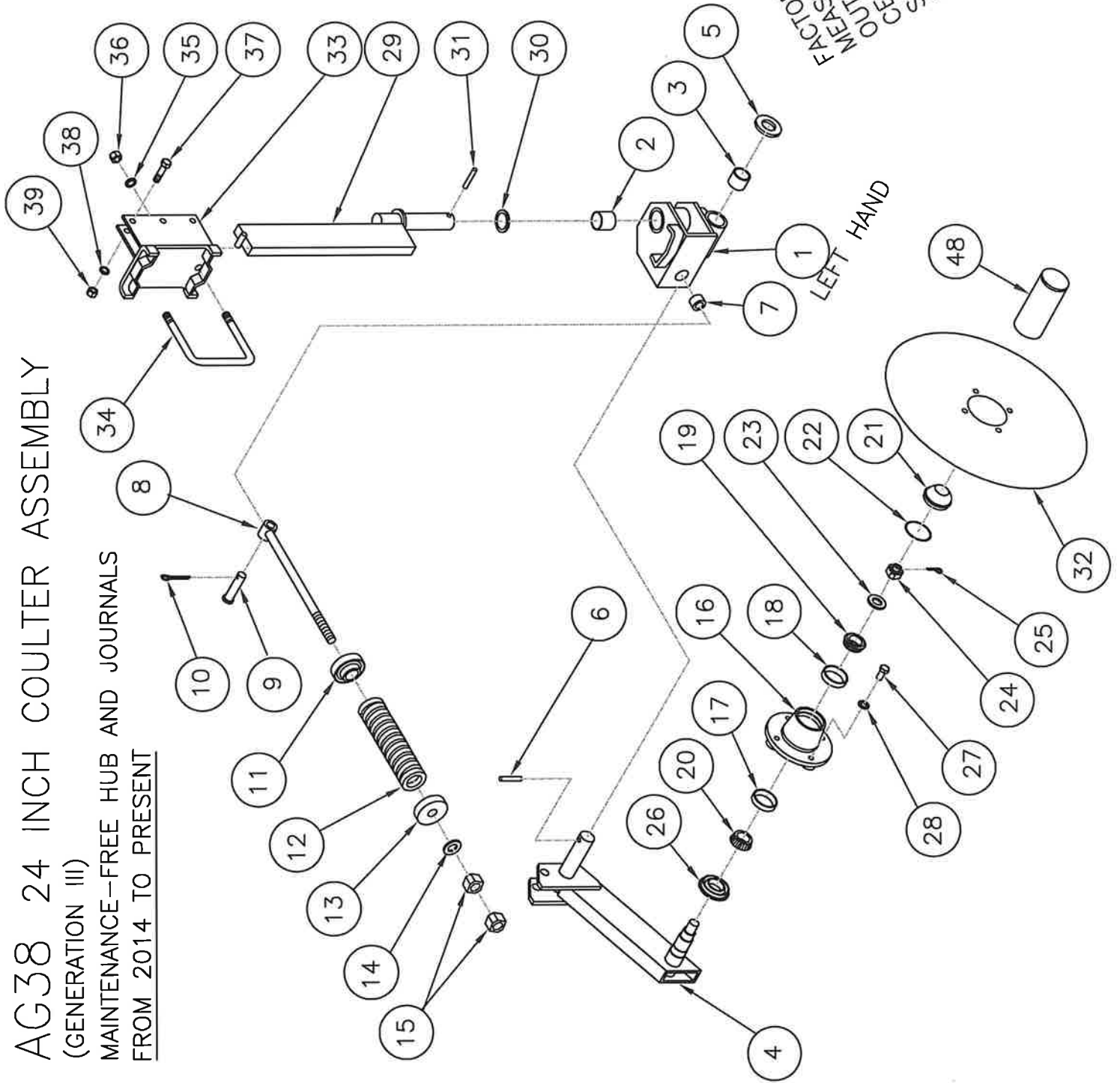

with MAINTENANCE-FREE HUB
MOUNTING INSTRUCTIONS AND PARTS LIST

- Your AG38 main bracket and hub are pre-assembled at the factory, and the trip springs are pre-loaded to provide 600 pounds blade pressure. This should be adequate for normal field conditions. The coultter arms should trip up only when hitting a solid obstruction. During your field operation check to make sure the coultter arm is staying rigid most of the time. Excessive flexing will cause premature spring failure. If repeated tripping is occurring tighten the spring tension till rigid operation is achieved.
- Assemble the blade (item 32) to the hub.
- Assemble the swivel bar (item 29) to the main bracket (item 1). Make sure that the 1 x 3 flat bar is positioned between the u-bracket stop on top of the main bracket. Install the washer (item 30) and roll pin (item 31).
- Position the mounting brackets (item 33) at the desired spacing and fasten with the u-bolts (item 34) and hardware (item 35 and item 36).
- Install the coultter assemblies to the mounting brackets (item 33) and fasten with the bolts (item 37) and hardware (item 38 and item 39). Assemble the hardware snug only.
- Adjust the coultter blade to the desired depth and tighten the hardware securely.
- Make sure "all" hardware is tightened securely.

8. No field operation lubrication is required. The hubs are sealed and greased for life. The swivel journals are assembled with grease-less bushings. For repair procedure, see separate sheet titled PROCEDURE TO SERVICE A COULTER HUB.

ITEM	PART NO.	DESCRIPTION	QTY
1	40350009	MAIN BRKT. W/HUB, LH, INCLUDES ITEMS 1 THRU 31 (W/O CLTR BLADE)	1
2	47305910	MAIN BRKT. W/HUB, LH, INCLUDES ITEMS 1 THRU 32 (WITH CLTR BLADE)	1
3	47004500	HOUSING W/BUSHINGS, L.H. (STD.)	1
4	47009953	SWIVEL BUSHING, 1 1/2 I.D.	2
5	47009954	PIVOT BUSHING, 1 3/8 I.D.	2
6	47005910	PIVOT ARM, L.H. FOR 24" BLADE ONLY	1
7	18300326	RETAINING WASHER, 1 3/8 I.D.	1
8	18511035	EXPANSION PIN, 3/8 X 2	1
9	2-6668	EYE BOLT GUIDE	1
10	47004518	EYE BOLT, SPRING RETAINER	1
11	18541835	CLEVIS PIN, 3/4 X 2 1/2	1
12	18560726	COTTER PIN, 5/32 X 1 1/2	1
13	47004521	SPRING CAP, WITH COUNTER-BORE	1
14	47007565	COMPRESSION SPRING	1
15	47007085	SPRING CAP, STANDARD CASTING	1
16	18851800	FLAT WASHER, 3/4	1
17	18446890	HEX. NUT, 3/4-10NC.	1
18	47300350	HUB COMPLETE (W/O SEAL & BOLTS) INCLUDES ITEMS 16 TO 22	2
19	47300351	HUB WITH CUPS ITEMS 17 & 18	1
20	47005510	BEARING CUP, INNER	1
21	47005010	BEARING CUP, OUTER	1
22	47005048	BEARING CONE, OUTER	1
23	47005548	BEARING CONE, INNER	1
24	47005513	DUST CAP	1
25	47990351	O-RING DUST SEAL	1
26	47300352	SPINDLE WASHER	1
27	47300353	SLOTTED NUT, 7/8-14UNF.	1
28	18560726	COTTER PIN, 5/32 X 1 1/2	1
29	40030326	GREASE SEAL	1
30	18057522	WHEEL BOLT, 1/2-20NF. X 1	4
31	18891400	LOCK WASHER, 1/2	4
32	47304522	COULTER SWIVEL BAR, 18"	1
33	18300323	RETAINING WASHER, 1 1/2 I.D.	1
34	18511036	EXPANSION PIN, 3/8 X 2 1/4	1
35	47305028	COULTER BLADE, 24" RIPPLED	1
36	47999888	MOUNTING BRACKET COMPLETE ASS'Y INCLUDES ITEMS 33 THRU 39	1
37	47309888	MOUNTING BRACKET, (6" VERTICAL)	1
38	47010154	U-BOLT, 5/8 NC. (6" VERT X 4"HORIZ)	1
39	18891600	LOCKWASHER, 5/8	2
40	18417900	HEX. NUT, 5/8-11NC.	2
41	18057434	BOLT, 1/2-13NC. X 2 1/2	3
42	18891400	LOCKWASHER, 1/2	3
43	18417400	HEX. NUT, 1/2-13NC.	3

**PROCEDURE TO SERVICE A COULTER HUB
"MAINTENANCE-FREE" HUB**

The factory procedure to assemble the coultter hub has been developed to obtain maximum life and to eliminate damage to the components. IT IS IMPORTANT to understand and follow this procedure when servicing the coultter hub. If possible, obtain an illustration of the coultter before proceeding.

ASSEMBLE THE COULTER HUB AS FOLLOWS.

- 1: Pre-pack the inner bearing cone with grease and insert it into the back of the hub.
- 2: Add grease to cover the back of the bearing and cup. CAUTION – CAUTION : Do not "fill" the back of the hub with grease. Do not get any grease on the sealing seat for the grease seal. The seal is treated with a sealing agent and grease or oil on the sealing surface will destroy the effectiveness of the seal. If there is any grease on the sealing surface in the hub wipe it with a degreasing agent.
- 3: Carefully insert the grease seal. Do not get any grease on the outer sealing surface of the seal. Tap or press the seal in place. Make sure the seal is entering and seating squarely.
- 4: Turn the hub over and fill the center cavity with grease. Pre-pack the outer bearing with grease and insert it into the hub.
- 5: Position the hub on the spindle and install the spindle washer and the slotted nut.
- 6: Rotate the hub by hand while tightening the slotted nut until the hub locks-up. This will align and seat the bearing rollers. Back off the nut until you can freely rotate the hub by hand and install the cotter pin. Bend the ends of the cotter pin "down" only. Not one half up and one half down.
- 7: Completely fill the front cavity of the hub with grease.
- 8: Inspect the hub to make sure it is properly assembled and then install the dust cap.
CAUTION: Once the dust cap is installed it cannot be removed without destroying it. Take care to be sure the dust cap is square to the bore when starting and seating it. An old dust cap or a piece of tubing with the right I. D. and O. D. may be helpful.
- 9: You may now assemble the coultter blade. During field operation check the coultter blade periodically for wobble. This could be a result of hitting rocks and/or normal wear. Re-adjust the bearing tension (see step 6). Wobble in the hub could damage the seal and cause bearing failure. Note that you will need to install a new dust cap after a bearing adjustment. REVIEW step 8.

SRVCLTRHUB

DSK201X13
REV 10-22-09

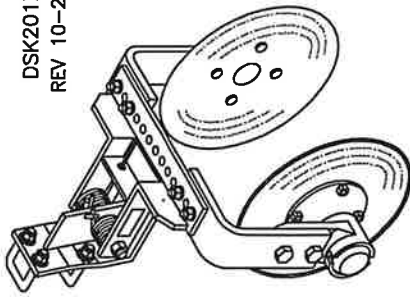

DISC COVER SEALER SPRING LOADED

ASSEMBLY P.N. 40034002 SMOOTH 13" DISC DOUBLE DISC
ASSEMBLY P.N. 40034004 SMOOTH 13" DISC SINGLE DISC

WITH BOLT-ON HUB

YEARS 2001 TO PRESENT

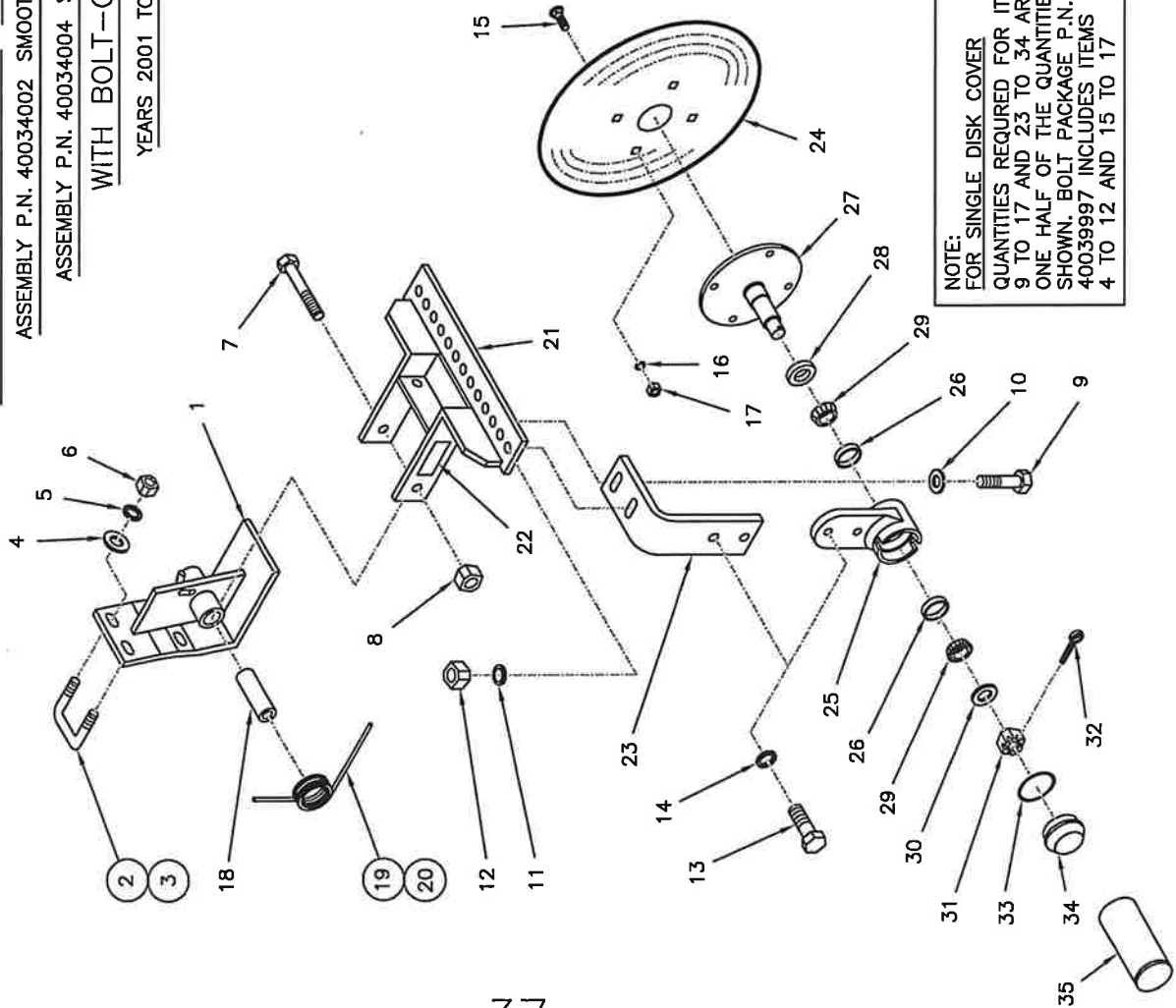

NOTE:
FOR SINGLE DISK COVER
QUANTITIES REQUIRED FOR ITEMS
9 TO 17 AND 23 TO 34 ARE
ONE HALF OF THE QUANTITIES
SHOWN. BOLT PACKAGE P.N.
40039997 INCLUDES ITEMS
4 TO 12 AND 15 TO 17

ITEM PART NO.	DESCRIPTION	QTY.
1	MOUNTING BRACKET	1
2	U-BOLT, 1/2-13NC. 2 in. SHANK	2
3	U-BOLT, 1/2-13NC. 1 1/4 in. SHANK	2
4	FLATWASHER, 1/2	4
5	LOCKWASHER, 1/2	4
6	HEX. NUT, 1/2-13NC.	4
7	BOLT, 5/8-11NC. X 5 1/2	1
8	HEX. LOCKNUT, 5/8-11NC.	1
9	BOLT, 1/2-13NC. X 2	4
10	FLATWASHER, 1/2	4
11	LOCKWASHER, 1/2	4
12	HEX. NUT, 1/2-13NC.	4
13	BOLT, 1/2-20NF. X 1 1/4	4
14	LOCKWASHER, 1/2	4
15	CARRIAGE BOLT, 3/8-16NC. X 1	4
16	LOCKWASHER, 3/8	8
17	HEX. NUT, 3/8-16NC	8
18	INNER BUSHING	1
19	TORSION SPRING, L.H.	1
20	TORSION SPRING, R.H.	1
21	DISC ARM FRAME	1
22	DECAL, "AG SYSTEMS" SMALL	1
23	DISC ARM	2
24	DISC BLADE, 13 INCH DIA.	2
25	HUB ASSEMBLY COMPLETE	2
26	INCLUDES ITEMS 13 & 14 & 25 TO 34	2
27	HUB WITH CUPS ITEM 26	2
28	BEARING CUP	4
29	SPINDLE WITH FLANGE	4
30	GREASE SEAL	2
31	BEARING CONE	2
32	FLATWASHER, 3/4 SAE (1 1/2 O.D.)	2
33	SLOTTED NUT, 3/4-16NF.	2
34	COTTER PIN, 5/32 X 1	2
35	O-RING DUST SEAL	2
	DUST CAP	2
	BOLT PACKAGE INCLUDES ITEMS-	1
	4 TO 6, 8 TO 12, AND 15 TO 17	1
	DUST CAP INSTALLATION TOOL (OPTIONAL)	1

DOUBLE DISC COVER SEALER "SPRING LOADED"

ASSEMBLY P.N. 40034000 SMOOTH 18" DISC

40034001 NOTCHED 18" DISC

WITH BOLT-ON HUB

(YEARS 2001 TO PRESENT)

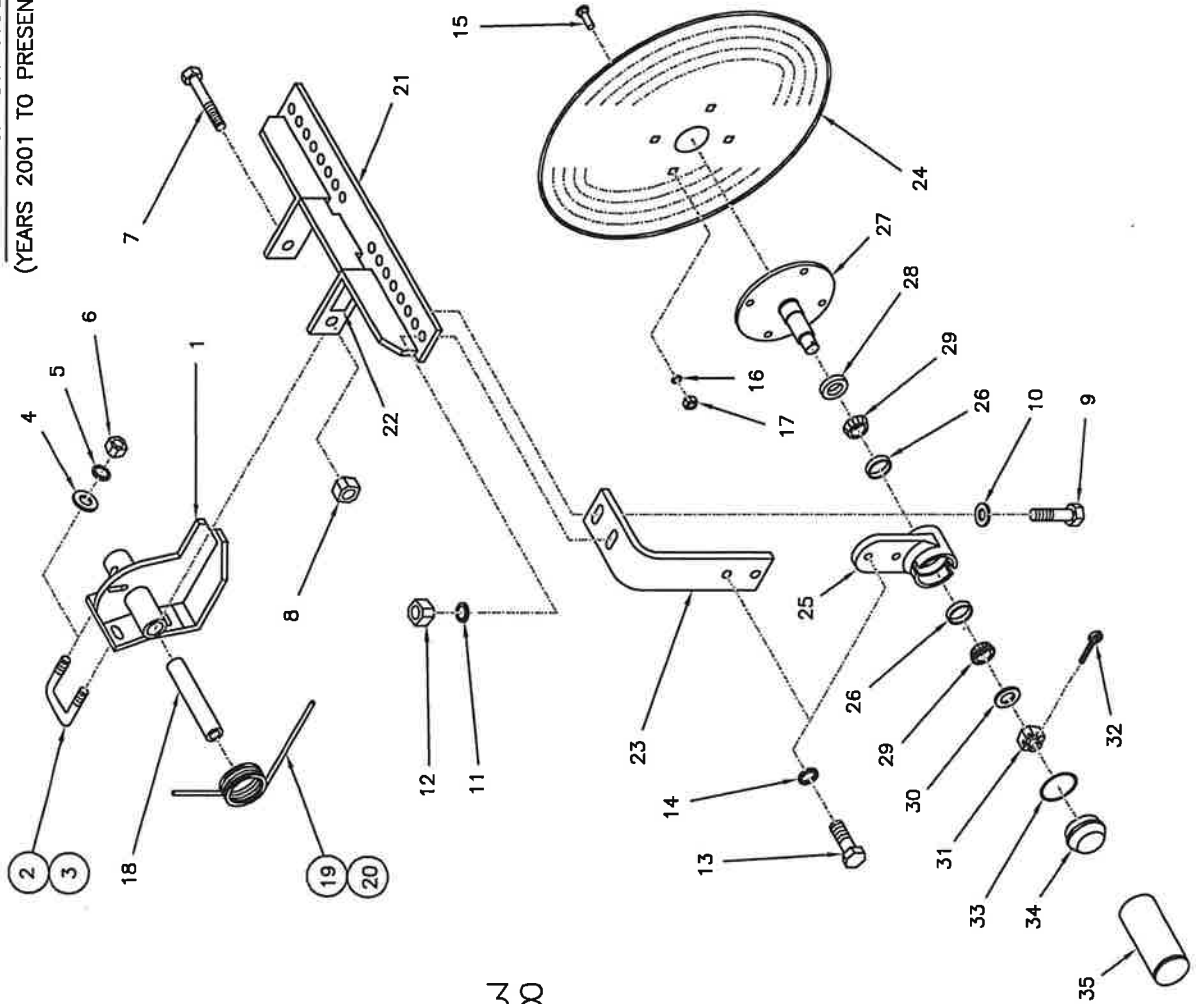

DSK201X18
REV 10-22-09

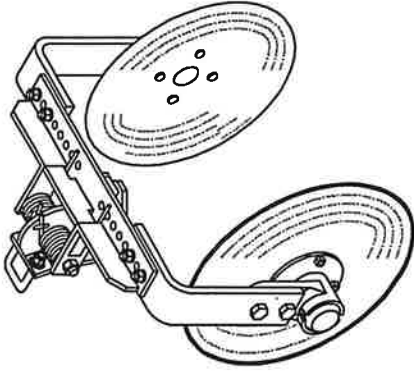

ITEM	PART NO.	DESCRIPTION	QTY.
1	47019325	MOUNTING BRACKET	1
2	47008396	U-BOLT, 1/2-13NC. 2 in. SHANK	2
3	47008397	U-BOLT, 1/2-13NC. 1 1/4 in. SHANK	2
4	18811400	FLATWASHER, 1/2	4
5	18891400	LOCKWASHER, 1/2	4
6	18417400	HEX. NUT, 1/2-13NC.	4
7	18057972	BOLT, 5/8-11NC. X 7 1/2	1
8	18457900	HEX. LOCKNUT, 5/8-11NC.	1
9	18057430	BOLT, 1/2-13NC. X 2	4
10	18811400	FLATWASHER, 1/2	4
11	18891400	LOCKWASHER, 1/2	4
12	18417400	HEX. NUT, 1/2-13NC.	4
13	18057523	BOLT, 1/2-20NF. X 1 1/4	4
14	18891400	LOCKWASHER, 1/2	4
15	18176450	CARRIAGE BOLT, 3/8-16NC. X 1	8
16	18891200	LOCKWASHER, 3/8	8
17	18436800	HEX. NUT, 3/8-16NC.	8
18	47009320	INNER BUSHING	1
19	47009326	TORSION SPRING, L.H.	1
20	47009327	TORSION SPRING, R.H.	1
21	47009317	DISC ARM FRAME	1
22	97445302	DECAL "AG SYSTEMS" SMALL	1
23	47009621	DISC ARM	1
24	44501810	DISC BLADE, SMOOTH EDGE	2
OR	44501811	DISC BLADE, NOTCHED EDGE	2
	47109558	HUB ASSEMBLY COMPLETE	OPT.
25	47009558	INCLUDES ITEMS 13 & 14 & 25 TO 34	2
26	10658	HUB WITH CUPS ITEM 26	2
27	47009328	BEARING CUP	4
28	40030325	SPINDLE WITH FLANGE	2
29	10659	GREASE SEAL	2
30	18841800	BEARING CONE	4
31	18488600	FLATWASHER, 3/4 SAE (1 1/2 O.D.)	2
32	18560722	SLOTTED NUT, 3/4-16NF.	2
33	47999558	COTTER PIN, 5/32 X 1	2
34	47005911	O-RING DUST SEAL	2
	40039999	DUST CAP	2
35	47005502	BOLT PACKAGE INCLUDES ITEMS- 4 TO 6, 8 TO 12, AND 15 TO 17 DUST CAP INSTALLATION TOOL (OPTIONAL)	1

SEE COULTER & DISK SEALER
MOUNTING INFO #SPGBDLSHK
DETAILED DIAGRAM TO MOUNT
DISK SEALER TO SHANK

DSKCVRMT1318
11-28-07

ASSEMBLY INSTRUCTIONS

DISC COVER SEALER

- 13 inch and 18 inch (WITH BOLT-ON-HUB)
- 13 INCH (REFER TO DIAGRAM DSK201X13)
- 18 INCH (REFER TO DIAGRAM DSK201X18)

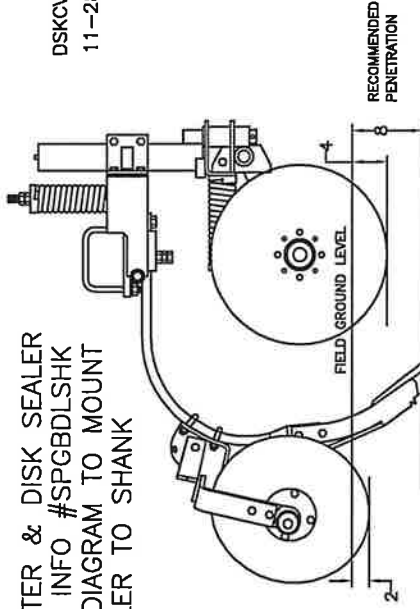

Your disc cover sealer assembly is partially assembled at the factory. The spindle (item 27) and all hub components are pre-assembled and greased for life.

1. Secure the mounting bracket (item 1) in a vise or assemble to the tool shank or some temporary assembly fixture.
2. Insert the bushing (item 18) into the mounting bracket (item 1). Position the torsion springs (item 19) left hand and (item 20) right hand over the pivot tube on the mounting bracket (item 1). The short legs of the springs should be next to the center gusset on the mounting bracket.
3. Position the disc arm frame (item 21) to the mounting bracket (item 1). Insert the long legs of the torsion springs into the holes in the crossbar on the disc arm frame. Assemble all with the bolt (item 7) and the locknut (item 8). Securely tighten the locknut and bolt so that the inner bushing (item 18) and the disc arm frame rotate as one unit.
4. Increase the tension on the torsion springs by hooking the short leg of the spring behind the retaining lugs welded to the gusset on the mounting bracket. A short length of 3/8 or 1/2 inch pipe will be helpful to bend the spring leg into position behind the lug.
5. Assemble the disc arm (item 23) to the hub assembly with the bolts (item 13) and lock washers (item 14). Secure the disc arm assembly in a vise and assemble the disc (item 24) to the spindle flange with the hardware (items 15, 16 and 17). The disc may be mounted concave to the row or convex (reverse) to the row. There is no difference between left hand or right hand assemblies or single or double disc assemblies.
6. Mount the disc arm assembly to the disc arm frame (item 21) with the bolts (item 9) and the hardware (items 10, 11 and 12) as illustrated with the nut on top of the disc arm frame. The suggested start-up position for a double disc assembly would be to mount the disc arm in the holes in the frame that are farthest to the outside. For a single disc cover or a reversed disc cover, holes farther to the center would be more appropriate. The slotted holes in the disc arm provide the angular adjustment for the disc. Position the disc(s) at the angle desired and securely tighten the hardware.
7. Your disc cover assembly is shipped with (2) U-bolts for a 1 1/4 square shank and (2) U-bolts for a 2 inch wide shank. Select the appropriate U-bolts and mount the disc cover assembly to the shank at the desired operating depth. Securely tighten the hardware.

DOUBLE DISK SEALER W/ FLOATING ARMS LAYOUT

CASE/DMI SHANK
(ASSEMBLY DIAGRAM)

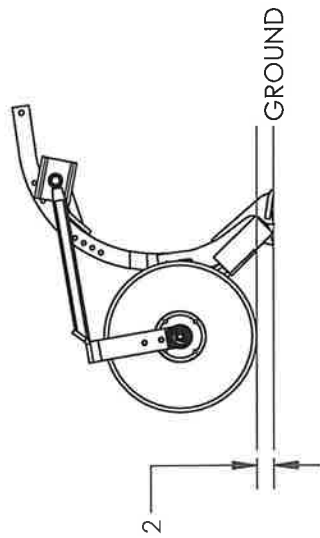

CASE/DMI SHANK
(RECOMMENDED PENETRATION DIAGRAM)

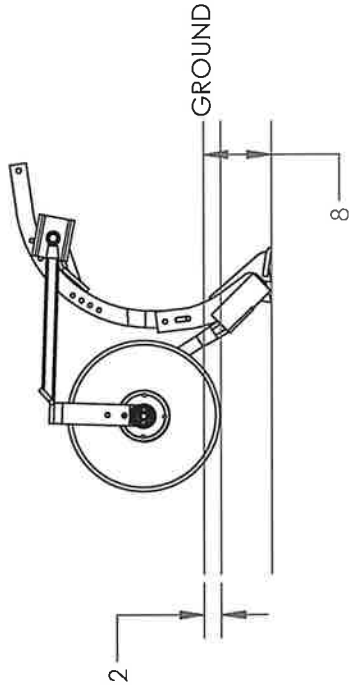

CASE/DMI SHANK
(TRANSPORT DIAGRAM)

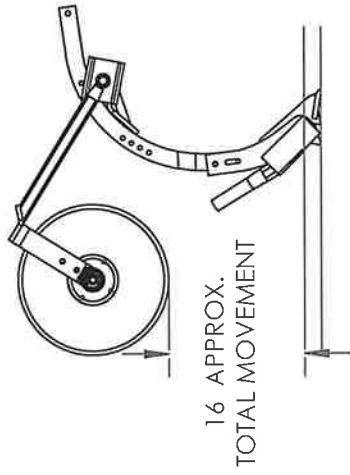

AG SYSTEMS HIGH TRIP EDGE BENT SHANK
(ASSEMBLY DIAGRAM)

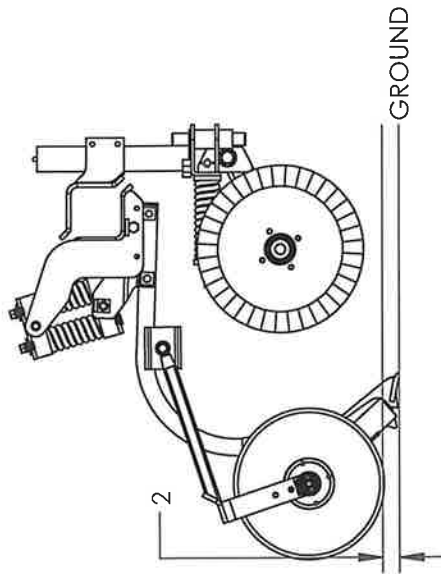

AG SYSTEMS HIGH TRIP EDGE BENT SHANK
(RECOMMENDED PENETRATION DIAGRAM)

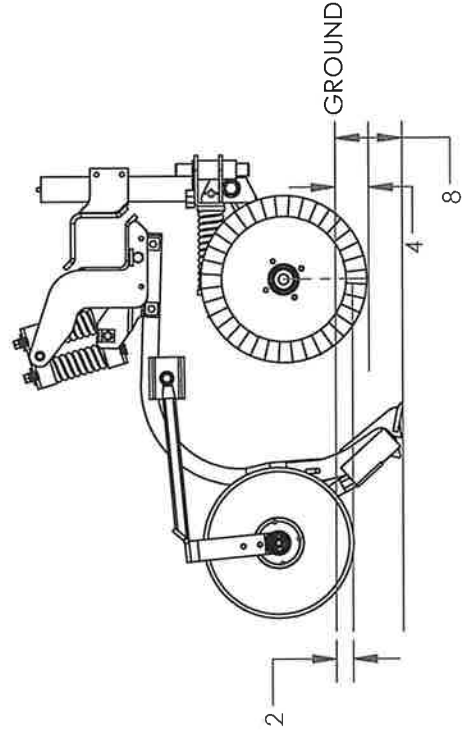

AG SYSTEMS HIGH TRIP EDGE BENT SHANK
(TRANSPORT DIAGRAM)

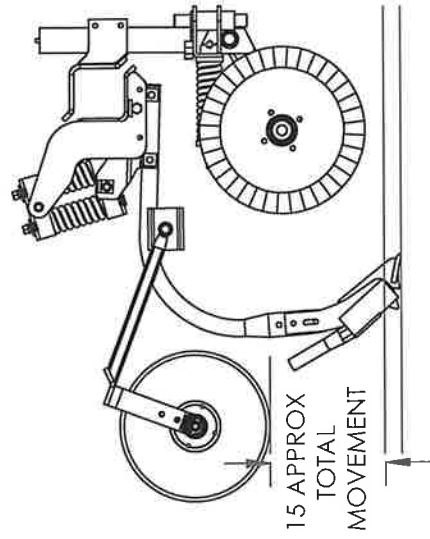

8500 TOOLBAR (16 1/2' CENTER SECTION) (40 FT)

W/HI-TRIP SPRING BUNDLES
16 ROWS AT 30 INCH SPACING
WITH COULTERS AND BUNDLES SEPARATED
AND FLOATING ARM DISC COVERS

850030x16MONTAGmod
PRO/06/10/16

47007924

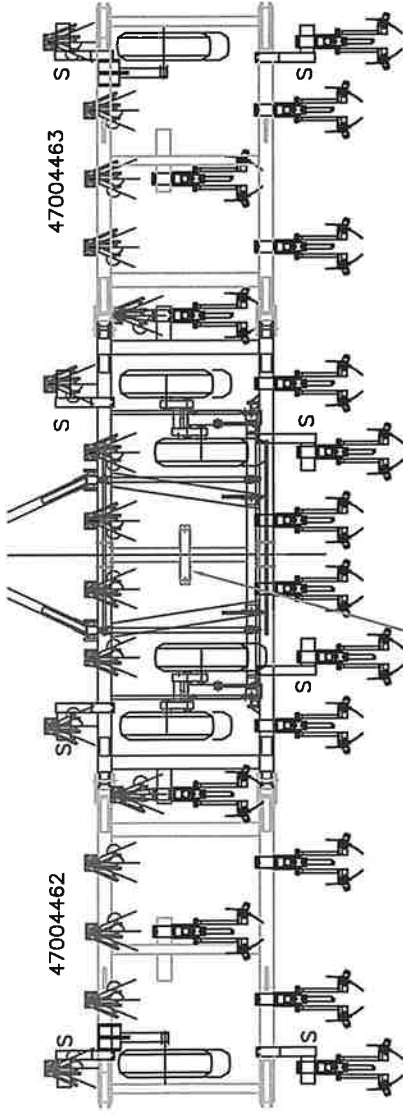

47995057 TWIN BALL MOUNT KIT FOR STEERABLE CART

STAGGER BRACKETS
QTY 8 SHORTS

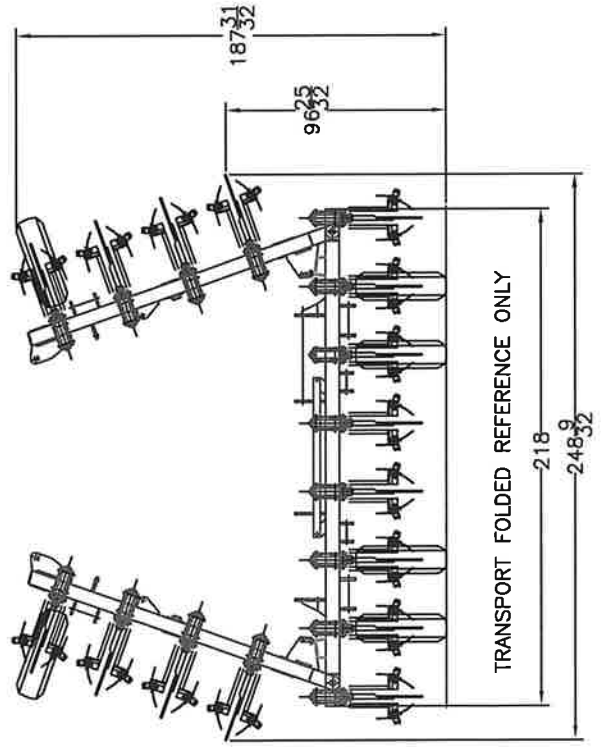

8500 TOOLBAR (16 1/2' CENTER SECTION) (55 FT)

85K22X30NARROW
PRO/04/05/18

22 SHANKS AT 30 INCH SPACING
W/HI-TRIP SPRING BUNDLES AND AG 38 COULTERS
WITH SINGLE FIELD HITCH

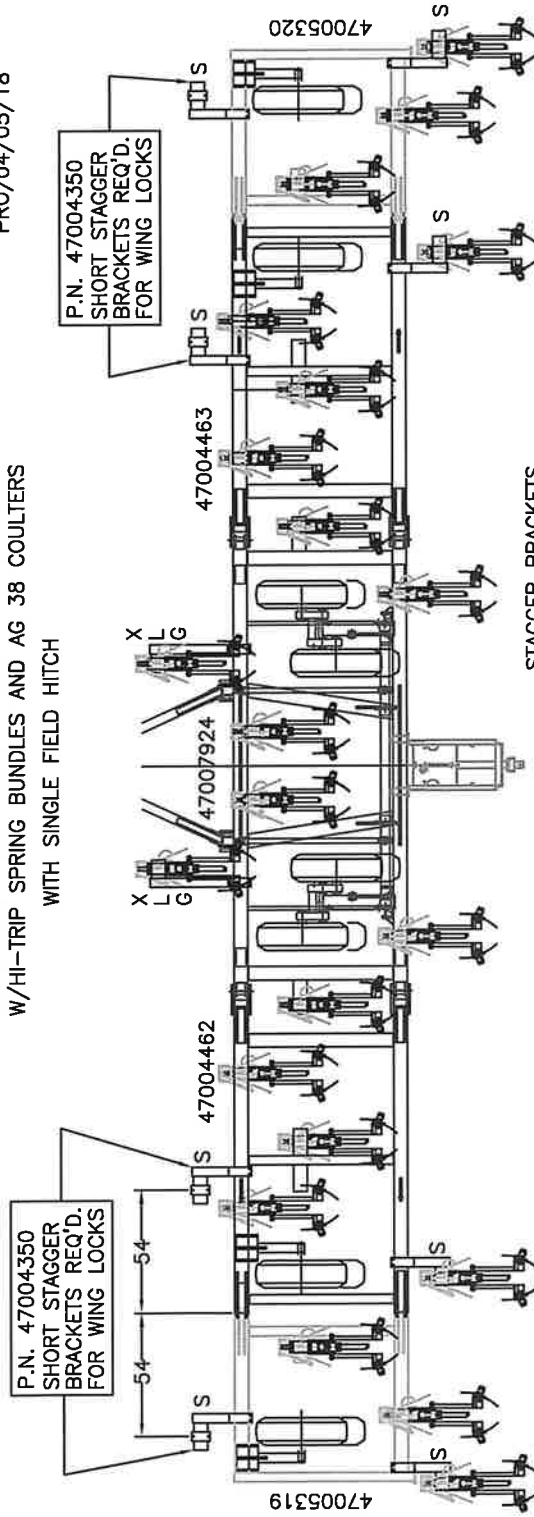

STAGGER BRACKETS
QTY 2 EXTRA-LONGS
QTY 8 SHORTS

8500 TOOLBAR (16 1/2' CENTER SECTION) (57 1/2 FT)

W/HI-TRIP SPRING BUNDLES
 AT 30 INCH SPACING WITH FLOATING ARM DISC COVERS
 23 ROWS AT 30 INCH SPACING
 WITH COULTER AND SHANKS SEPARATED

850030x23SPLIT
 REV 05/31/18

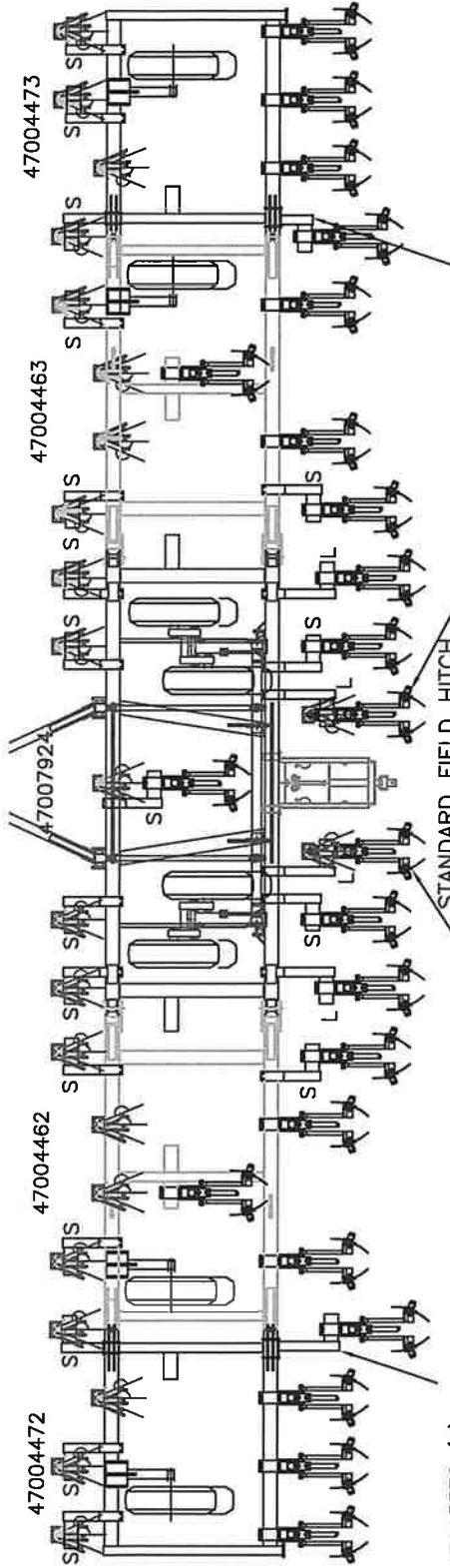

47005572 (1)
 23 1/2 inch stagger
 (u-bolt style)

23 1/2 and 11 1/2" staggers on
 opposite wings allow clearance for
 folding into the transport position.

47005095 (1)
 11 1/2 inch stagger
 (u-bolt style)

- STAGGER BRACKETS
 QTY 19 SHORTS
 QTY 4 LONGS
 QTY 1 (47005095)
 QTY 1 (47005572)

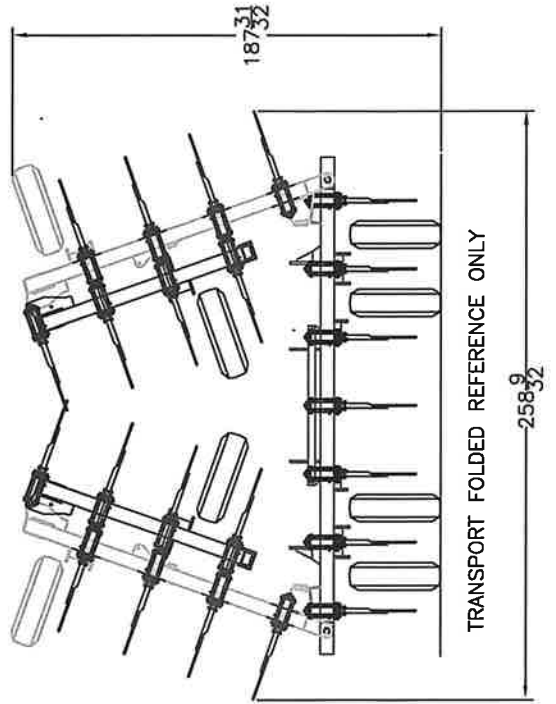

8500 TOOLBAR (16 1/2' CENTER SECTION)(60 FT)

W/HI-TRIP SPRING BUNDLES
 24 ROWS AT 30 INCH SPACING
 WITH COULTERS AND BUNDLES SEPARATED
 AND FLOATING ARM DISC COVERS
 47007924

850030x24SPLITN
 REV 12/20/18

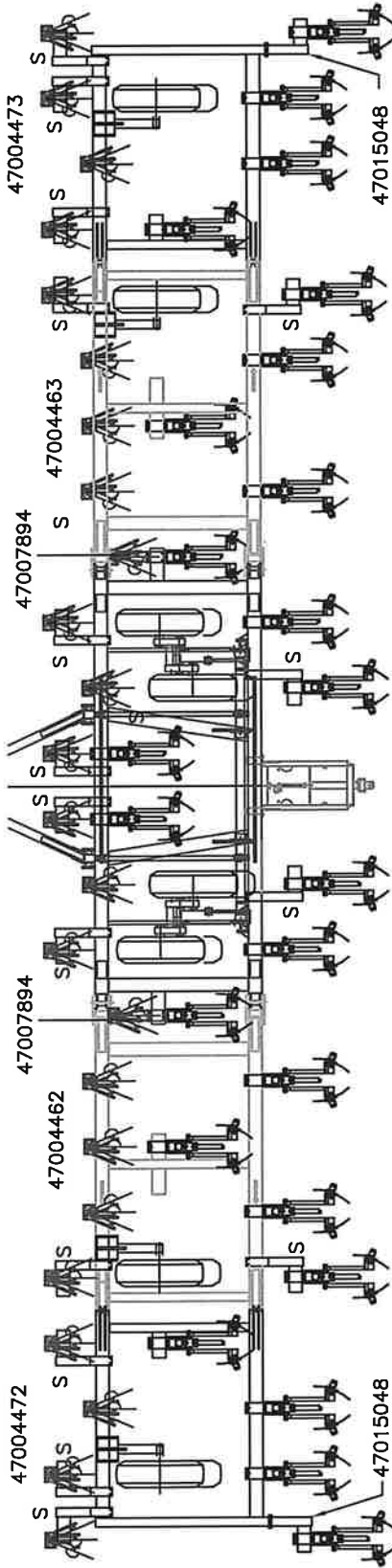

AND STANDARD FIELD HITCH

STAGGER BRACKETS
 QTY 16 SHORTS (47004350)
 QTY 2 (47015048)
 QTY 2 (47007894)

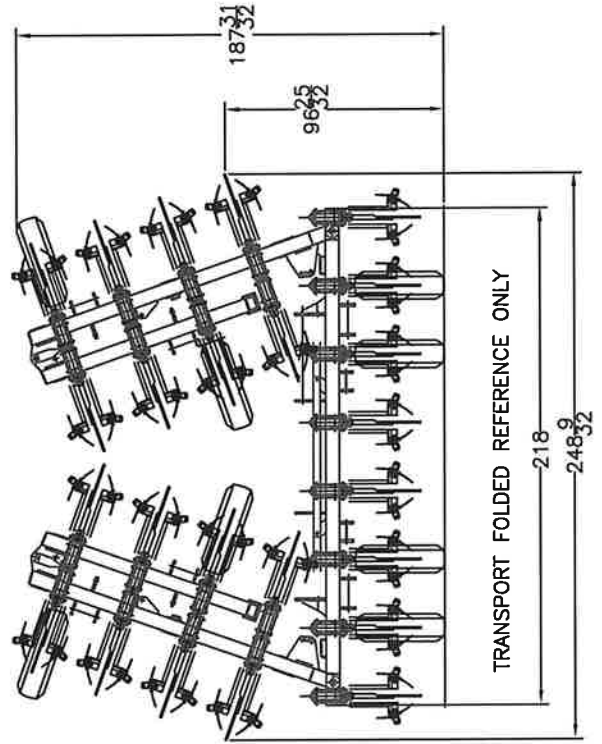

8500 TOOLBAR (16 1/2' CENTER SECTION) (60 FT)

850030x24HTRP
REV 05/31/18

W/HI-TRIP SPRING BUNDLES
AT 30 INCH SPACING
AND STANDARD FIELD HITCH

24 ROWS AT 30 INCH SPACING
47007924

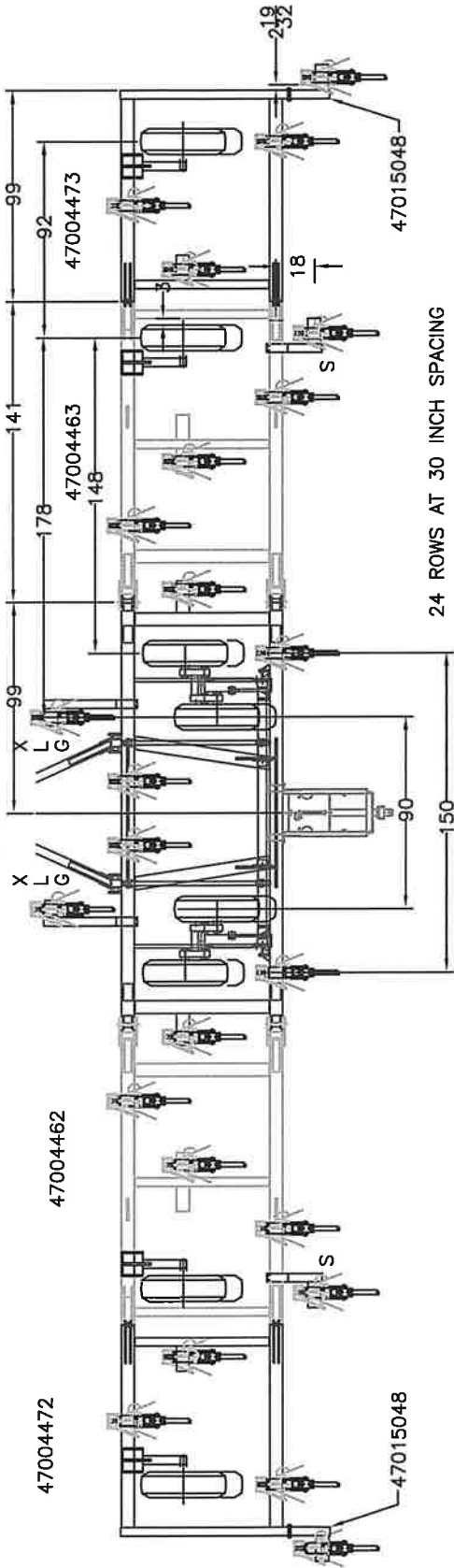

- STAGGER BRACKETS
- QTY 2 SHORTS
- QTY 2 XTRA-LONGS
- QTY 2 (47015048)

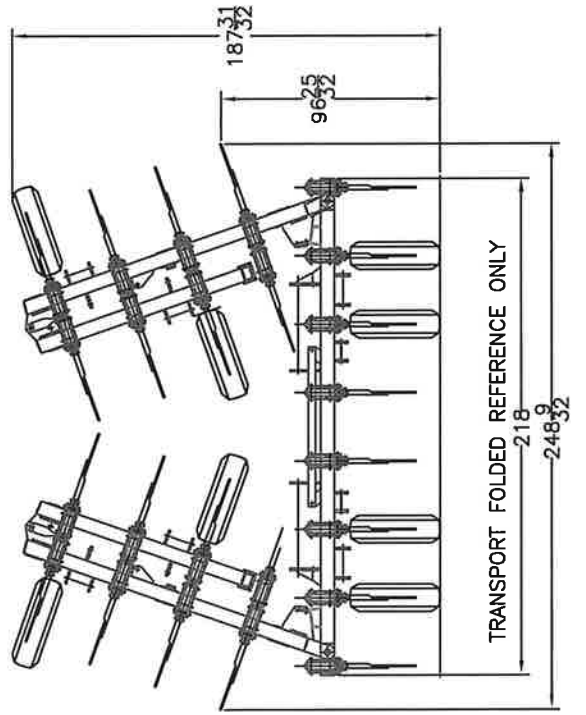

8500 TOOLBAR (16 1/2' CENTER SECTION)

W/HI-TRIP SPRING BUNDLES
AT 20 INCH SPACING
AND STANDARD FIELD HITCH
34 ROWS AT 20 INCH SPACING

850020x34HTRP
PRO 11-18-15

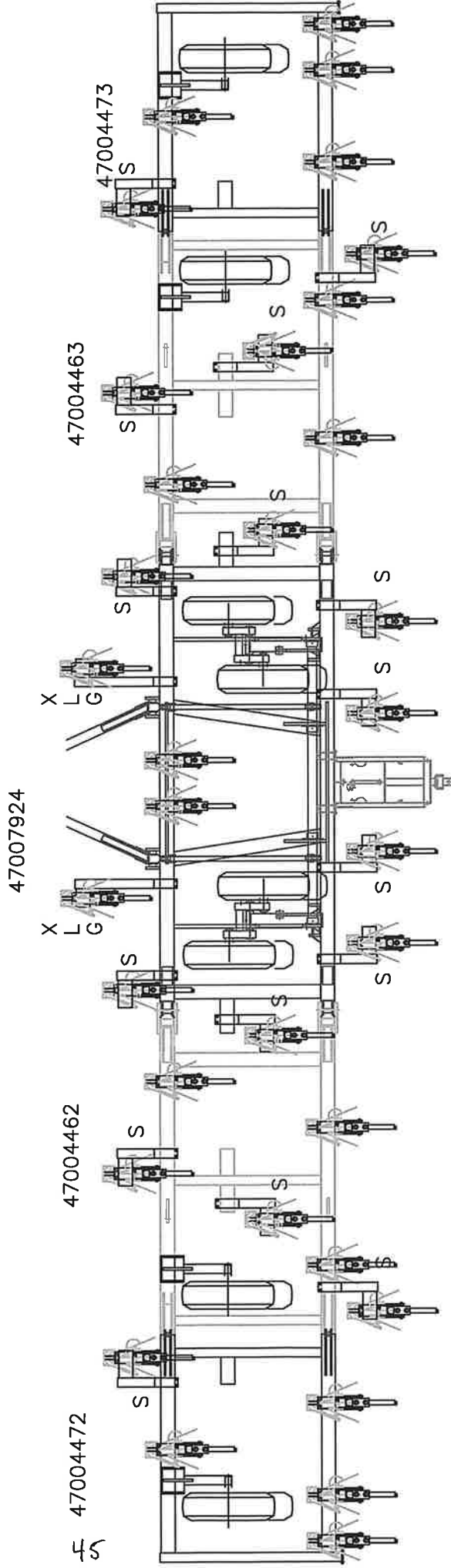

34 ROWS AT 20 INCH SPACING

STAGGER BRACKETS
QTY 16 SHORTS
QTY 2 XTRA-LONGS

8500 TOOLBAR (16 1/2' CENTER SECTION) 58.75 FT

47 ROW W/SHANKS AT 15 INCH SPACING
 SPRING BUNDLES WITH COULTERS
 AND SINGLE FIELD HITCH

85K47X15AC36
 rev 05/31/18

47007924 LONGS REQ'D FOR RAVEN COOLER CLEARANCE

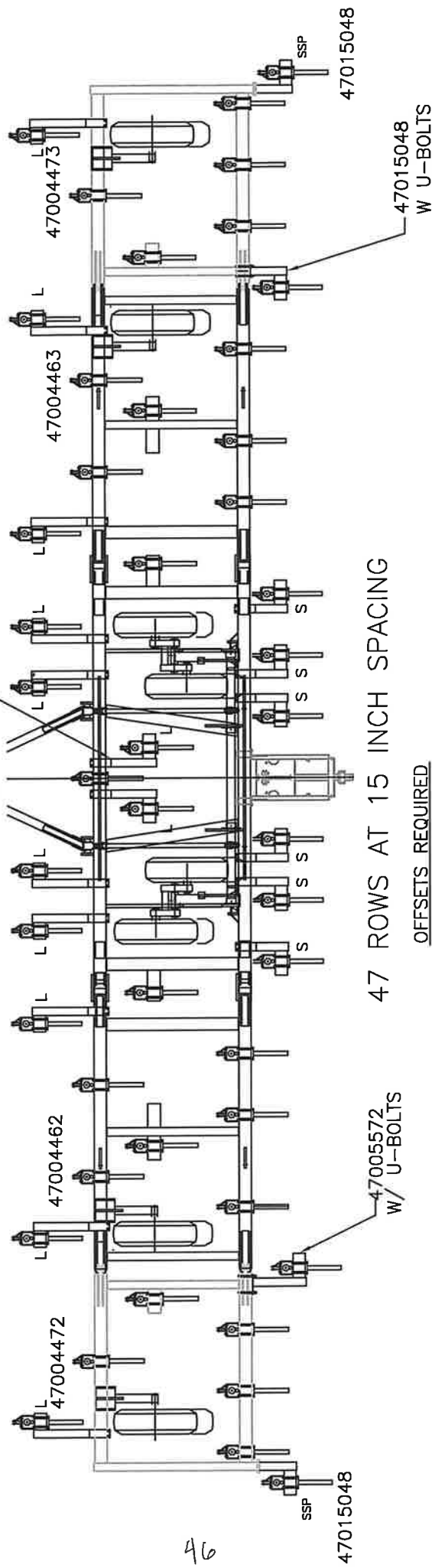

47 ROWS AT 15 INCH SPACING

OFFSETS REQUIRED

- QTY 6 SHORTS
- QTY 12 LONGS
- QTY 2 SSP (47015048) WITH U-BOLTS
- QTY 1 SSP (47015048) WITH U-BOLTS
- QTY 1 SSP (47005572) WITH U-BOLTS

NH3 APPLICATION OPTIONS
PARTS LIST

ITEM NO.	PART NO.	DESCRIPTION	QTY.
1	47010175	CENTER MANIFOLD STAND ASSEMBLY COMPLETE CONSISTS OF ITEMS 1 TO 19	1
2	47010124	UPPER STAND	1
3	47010172	LOWER STAND	1
4	47010129	DECAL WING - LEFT	1
5	47010130	DECAL WING - RIGHT	1
6	47010128	BUSHING	2
7	47010242	SPACER TUBE	1
8	47003898	SPACER WASHER, SS	1
9	18056468	SPRING, 4.50 LONG	1
10	18496400	BOLT, 5/16-18NC, X 3 1/2	2
11	18496400	FLANGE NUT, 5/16-18NC, (6 X 4 TUBE)	2
12	47009956	U-BOLT, 3/8-16NC, (6 X 6 TUBE)	2
13	47009956	U-BOLT, 3/8-16NC, (6 X 6 TUBE)	2
11A		WHEN MOUNTING THE LOWER STAND (ITEM 2) ON A FIELD FITCH WITH THE MOUNTING PLATE, P.N. 47009865 USE (4) BOLTS, 3/8-16NC, X 1 1/4, P.N. 18056624	4
12	18991200	LOCKWASHER, 3/8	4
13	18436800	HEX NUT, 3/8-16NC, X 5 1/4	4
14	18057425	BOLT, 1/2-13NC, X 5 1/4	4
15	18811400	WASHER, FLAT, USS 1/2 ZC	2
16	18457650	HEX. NUT, CTR LOCK 1/2-13 ZC	1
17	97445303	DECAL - AG SYSTEMS (SMALL)	1
18A	FM125-2000	DECAL - DANGER (FLOMAX)	1
18B	9070034	DECAL - DANGER (PIONEER)	1
19A	699103	DECAL - OPERATION & MAINT. INSTRUCTIONS	1
19B	699102	DECAL - DANGER	1
19C	699105	DECAL - SAFETY INSTRUCTIONS	1
20	47010155	CLAMP PLATE	1
21	18056458	BOLT, 5/16-18NC, X 3	3
22	18496400	FLANGE NUT, 5/16-18NC, (6 X 4 TUBE)	3
23	70245	MANIFOLD STAND ASSEMBLY CONSISTS OF THE FOLLOWING	1 EACH
	2-2524	MANIFOLD SUPPORT	1 EACH
	2-6371	CLAMP PLATE	1 EACH
	18037456	BOLT 1/2-13NC, X 5 1/2	2 EACH
	18891400	LOCKWASHER, 1/2	2 EACH
	18417400	HEX. NUT, 1/2-13NC	2 EACH
		OPTIONAL	
24	47010236	NH3 CONTROL BRACKET	1
25	47006951	U-BOLT, 5/8-11NC, (6 X 4 TUBE)	2
26	18891600	LOCKWASHER, 5/8	4
27	18417900	HEX. NUT, 5/8-11NC	4
		OPTIONAL	
28	47010381	MANIFOLD SUPPORT (3" OFFSET)	4
29	47010382	MANIFOLD SUPPORT (2" OFFSET)	1
30	47001028	U-BOLT, 3/8-13NC,	5
31	18891200	LOCKWASHER, 3/8	10
32	18436800	HEX. NUT, 3/8-16NC,	10
		OPTIONAL	
33	47019993	MANIFOLD SUPPORT, (6 X 6 TUBE)	2
34	47009866	U-BOLT, 3/8-13NC, (6 X 6 TUBE)	2
35	18891200	LOCKWASHER, 3/8	4
36	18436800	HEX. NUT, 3/8-16NC,	4
		OPTIONAL	
37	47004592	UTILITY BRACKET (6 X 6 TUBE)	1
	47004621	UTILITY BRACKET (UNIV) (6 X 4 TUBE)	1
38	47006950	U-BOLT, 5/8-11NC, (6 X 6 TUBE)	2
	44001616	U-BOLT, 5/8-11NC, (4 X 4 TUBE)	OR
39	47006951	U-BOLT, 5/8-11NC, (6 X 4 TUBE)	OR
40	18457900	HEX. LOCKNUT, 5/8-11NC,	4
41	47004625	STAND MOUNT BRACKET	1
42	47009866	U-BOLT, 3/8-16NC,	2
43	18891200	LOCKWASHER, 3/8	4
	18436800	HEX NUT, 3/8-16NC	4

NH3 DISTRIBUTION
STANDS AND BRACKETS

ITEM NO.	PART NO.	DESCRIPTION	QTY.
44	47005077	OPTIONAL MT PKG FOR RAVEN COOLER (8000) BRACKET	2
45	18057926	BOLT, HEX HD 5/8 X 1 1/2 GR5 ZC	8
46	18891600	LOCKWASHER, 5/8 ZC	16
47	18417900	NUT, 5/8 NC ZC	16
48	47010154	U-BOLT 5/8 (fits 4 x 6 tube)	4
44	47015077	OPTIONAL MT PKG FOR RAVEN COOLER (8500) BRACKET	2
45	18057926	BOLT, HEX HD 5/8 X 1 1/2 GR5 ZC	8
46	18891600	LOCKWASHER, 5/8 ZC	16
47	18417900	NUT, 5/8 NC ZC	16
49	47006950	U-BOLT 5/8 (fits 6 x 6 tube)	4
44A	47995838	OPT. MT PKG FOR RAVEN Vortex COOLER (8500) BRACKET (for Raven Accuflow Vortex)	1
46	18891600	LOCKWASHER, 5/8 ZC	10
47	18417900	NUT, 5/8-11 NC ZC	10
49	47006950	U-BOLT 5/8 (fits 6 x 6 tube)	2
50	47019839	U-BOLT 5/8 (fits 2, x 4 tube)	3
51	18811600	FLATWASHER, 5/8 ZC	4

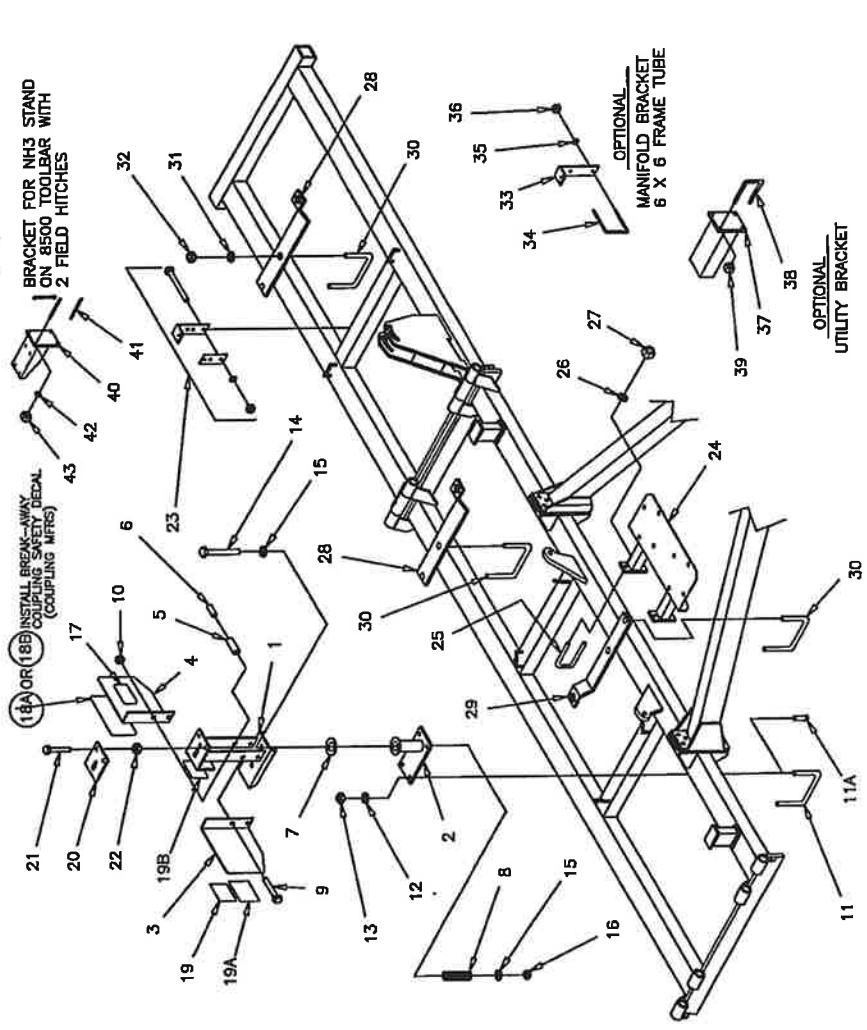

NH3 QUICK COUPLER STAND KIT (2015) for NH3 TOOLBARS (swing arm style)

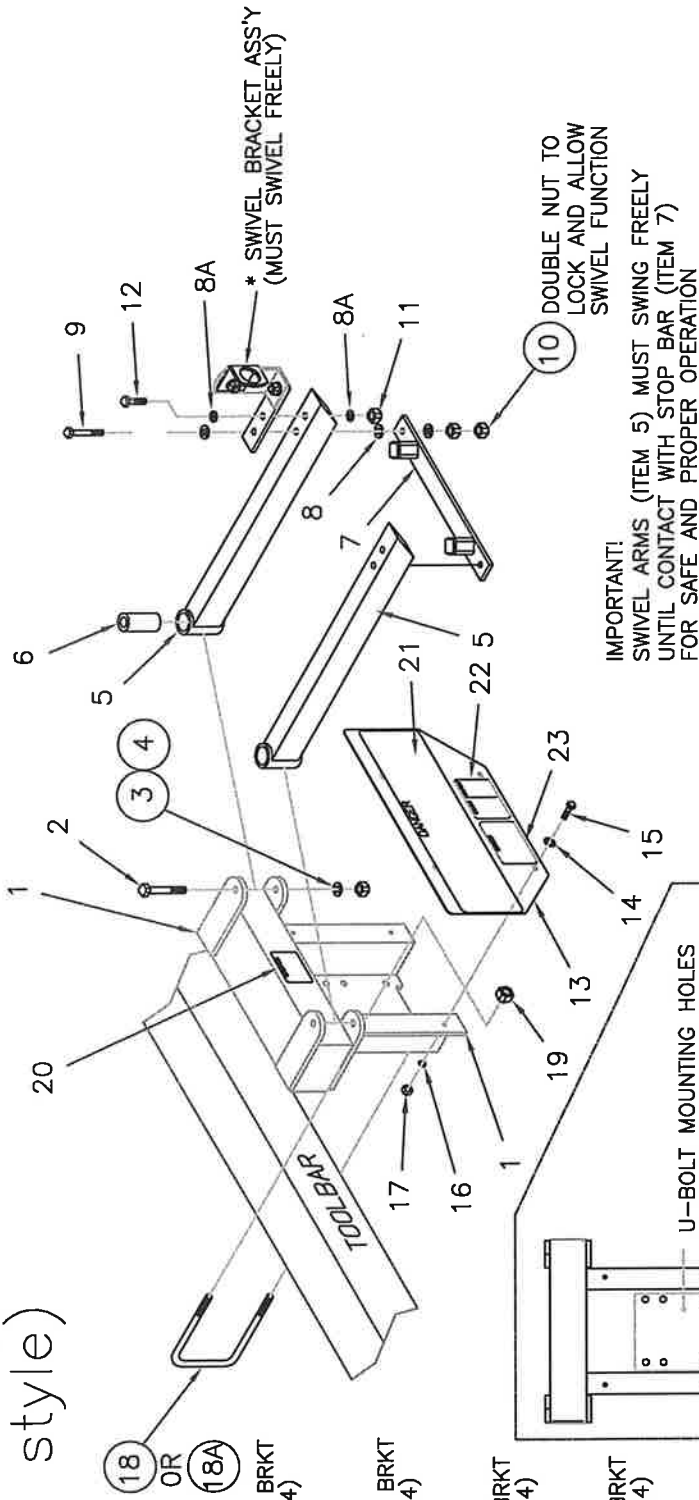

47015908
COMPLETE SINGLE QUICK DISCONNECT BRKT
ASSEMBLY (INCLUDES ITEMS 1 THRU 24)
(FITS 4 X 6 TOOLBAR FRAME ONLY)

47025908
COMPLETE SINGLE QUICK DISCONNECT BRKT
ASSEMBLY (INCLUDES ITEMS 1 THRU 24)
(FITS 6 X 6 TOOLBAR FRAME ONLY)

47035908
COMPLETE DUAL QUICK DISCONNECT BRKT
ASSEMBLY (INCLUDES ITEMS 1 THRU 24)
(FITS 4 X 6 TOOLBAR FRAME ONLY)

47045908
COMPLETE DUAL QUICK DISCONNECT BRKT
ASSEMBLY (INCLUDES ITEMS 1 THRU 24)
(FITS 6 X 6 TOOLBAR FRAME ONLY)

ITEM	SINGLE QTY	DUAL QTY	PART NO.	DESCRIPTION	ITEM	SINGLE QTY	DUAL QTY	PART NO.	DESCRIPTION
1	1	1	47005908	HINGE MOUNT WELDMENT	14	4	4	18811100	FLATWASHER, USS 5/16 ZC
2	1	2	18058458	BOLT, HEX 3/4 NC X 6 GR5 ZC	15	4	4	18056424	BOLT, HEX 5/16NC X 1 1/4 ZC
3	1	2	18811800	FLATWASHER, 3/4 ZC	16	4	4	18891110	LOCKWASHER, 5/16 ZC
4	1	2	18458400	NUT, CENTER LOCK 3/4 NC ZC	17	4	4	18406400	NUT, HEX 5/16 NC ZC
5	1	2	47005901	SWING ARM WELDMENT	18	2	2	47009847	U-BOLT, 5/8 (fits 6 x 6 tube)
6	1	2	47005904	SWIVEL BUSHING	OR				
7	1	1	47005914	TIE BAR WELDMENT	18A	2	2	47006951	U-BOLT, 5/8 (fits 4 x 6 tube)
8	3	6	18811400	FLATWASHER, 1/2 USS ZC	19	4	4	18417900	NUT, HEX 5/8 NC ZC
8A	2	4	18851400	FLATWASHER, 1/2 SAE ZC	20	1	1	699105	DECAL, SAFETY INSTRUCTIONS
9	2	2	18057454	BOLT, 1/2 NC X 5 LONG GR5 ZC	21	1	1	FM125-2000	DECAL, DANGER, (Flomax coupler safety)
10	2	4	18417400	NUT, HEX 1/2 NC ZC	22	1	1	699103	DECAL, OPER & MAINT. INSTRUCTIONS
11	2	4	18457650	LOCKNUT, HEX 1/2 NC ZC	23	1	1	699102	DECAL, DANGER, (hazard, don't breathe)
12	2	2	18057424	BOLT, 1/2 NC X 1 1/4 LG GR5 ZC					
13	1	1	47005900	DECAL PANEL					

NH3 APPLICATION PLUMBING

10397

NH3 APPLICATION SCHEMATIC WITH 2 MANIFOLDS

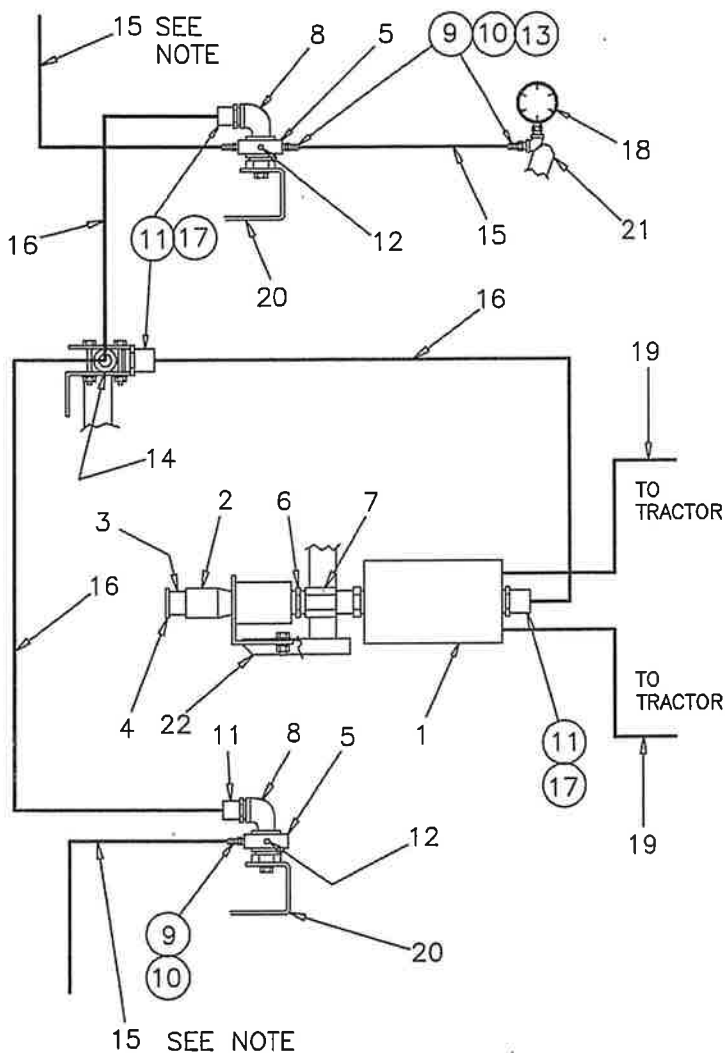

NH3 APPLICATION SCHEMATIC WITH ONE MANIFOLD

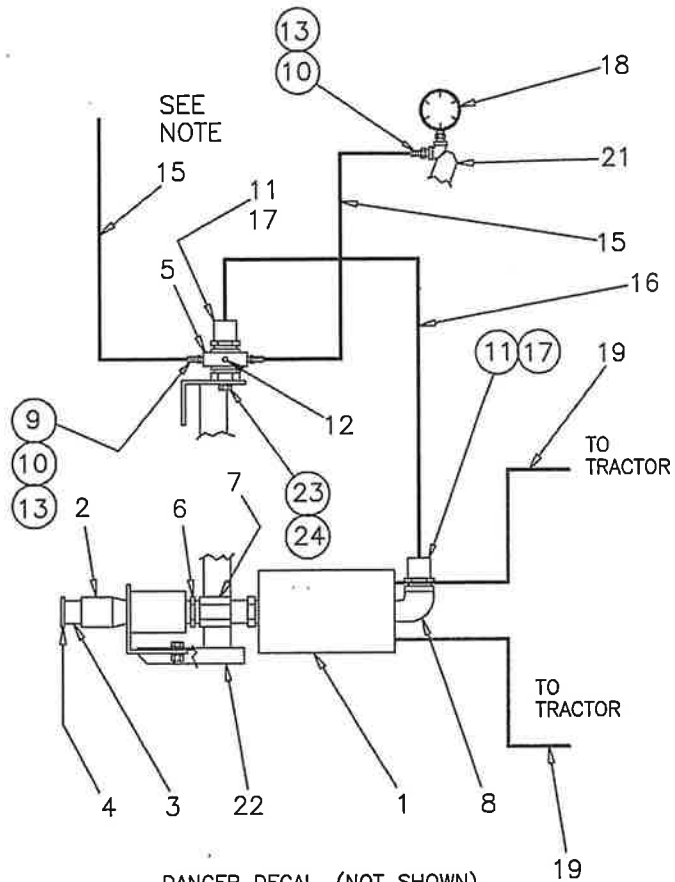

DANGER DECAL, (NOT SHOWN) WHICH IS SUPPLIED WITH ITEM 2, (QUICK COUPLER) ATTACH TO FIELD HITCH

NOTE: FOR ITEM 15 CUT IDENTICAL LENGTHS OF TUBING FOR EACH KNIFE.

ITEM	PART NO.	DESCRIPTION	34 FT. TOOLBAR SHANK SPACING			42 FT. TOOLBAR SHANK SPACING			52 FT. TOOLBAR SHANK SPACING		
			15"	18"	36"	15"	18"	36"	15"	18"	36"
1	100186	B-9500 METER	1	-	ALL						
2	100399	QUICK COUPLER	1	-	ALL						
3	111430	ACME ADAPTER	1	-	ALL						
4	111585	DUST CAP W/CHAIN	1	-	ALL						
5	111259	MANIFOLD, 1/4 X 16 PORT	X	X	1	1					
5	100147	MANIFOLD, 1/8 X 18 PORT	2	X	X	2	2	1	1	X	2
5	100170	MANIFOLD, 1/8 X 24 PORT	X	1	1	X	X	X	X	2	X
6	5404-20	HEX. PIPE NIPPLE, 1 1/4	1	-	ALL						
7	5000-20-HEX	HEX. COUPLING, 1 1/4	1	-	ALL						
8	72306	STREET ELBOW, 1" NPT	2	1	1	2	2	1	1	2	2
9	100172	HOSE BARB, 1/8 X 3/8 HOSE	28	24	X	X	36	29	18	16	42
10	111510	HOSE BARB, 1/4 X 3/8 HOSE	1	1	15	13	1	1	1	1	1
11	200277	HOSE BARB, 1 X 1 HOSE	3	2	2	2	3	3	2	2	3
12	72025	PIPE PLUG, 1/8 NPT	8	X	X	X	X	7	X	2	6
12	72019	PIPE PLUG, 1/4 NPT	X	X	3	5					14
13	602305	HOSE CLAMP, (WIRE TYPE)	56	48	28	24	72	58	36	32	85
14	72292	TEE, 1" NPT	1	X	X	X	1	1	X	X	1
15	15017005	TUBING 3/8" (FT.=)	325	440	280	240	545	450	440	390	840
16	15018576	TUBING 1" (FT.=)	31	3	3	3	31	31	3	3	31
17	200252	HOSE CLAMP, (SCREW TYPE)	6	2	2	2	6	6	2	2	6
18	100352	GAUGE, (0-60)	1	-	ALL						
19	609220	HYD. HOSE, 1/4 X 22 FT.	2	-	ALL						
20	70245	MANIFOLD STAND	2	X	X	X	2	2	X	X	2
21	47010168	GAUGE BRACKET	1	-	ALL						
22	47010175	NH3 STAND ASSEMBLY	1	-	ALL						
23	18056822	3/8-16 NC X 1" BOI	X								
24	18406800	3/8 LOCKWASHER	X								

NH3 DISTRIBUTION STAND AND BREAK-AWAY COUPLING DEVICE INSTALLATION, OPERATION AND MAINTENANCE INSTRUCTIONS

NH3STNDKITZ
REV 08-29-12

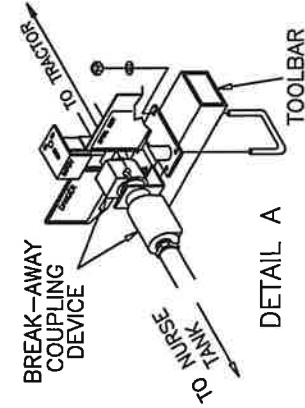

BREAK-AWAY COUPLING DEVICE & NH3 STAND
THE PURPOSE OF THE BREAK-AWAY COUPLING DEVICE IS THAT IN THE EVENT OF A TRAILING NURSE TANK WAGON BECOMING INADVERTENTLY UNFITTED AND DISCONNECTED FROM THE TOOLBAR, THE BREAK-AWAY COUPLING IS INSTALLED TO PROVIDE AN AUTOMATIC VALVE CLOSURE TO REDUCE THE AMOUNT OF NH3 THAT IS RELEASED INTO THE AIR AND REDUCE THE HAZARD TO THE TOOLBAR OPERATOR AND OTHERS.

THE NH3 STAND MOUNTS THE BREAK-AWAY COUPLING DEVICE TO THE TOOLBAR SECURELY BUT ALLOWS THE COUPLING DEVICE TO SWIVEL FREELY AND ALLOWS IT TO SAFELY DISCONNECT DURING AN INCIDENT WITHOUT CAUSING DAMAGE TO THE BREAK-AWAY COUPLING DEVICE. THE HOSE OR FITTINGS ATTACHED TO THE COUPLER AT THE SWIVEL BRACKET MUST NOT CATCH ON ANYTHING THAT WOULD PREVENT THE REQUIRED MOVEMENT DURING A PULL-AWAY EVENT.

NH3 STAND/ BREAK AWAY COUPLER INSTALLATION PROCEDURE

1. BOLT THE PRE-ASSEMBLED NH3 STAND ASSEMBLY TO THE REAR OF THE TOOLBAR CENTERED OVER THE FIELD HITCH USING U-BOLTS OR SUPPLIED BRACKETS. SEE YOUR SPECIFIC TOOLBAR MODEL OWNERS MANUAL AND NH3 STAND ILLUSTRATION FOR PARTS REQUIRED. (REF DETAIL A) MAKE SURE THE NH3 STAND DECALS CAN BE EASILY READ FACING THE REAR OF THE TOOLBAR. IMPORTANT! INSTALL THE BREAK-AWAY COUPLING MANUFACTURERS WARNING DECAL ON THE TOOLBAR CENTERED OVER THE FIELD HITCH WHERE IT CAN BE EASILY READ.
2. MOUNT THE BREAK-AWAY COUPLER PER THE INSTRUCTIONS INCLUDED BY THE SPECIFIC COUPLERS MANUFACTURER. THE MOUNTED COUPLER MUST BE ABLE TO FREELY SWIVEL APPROXIMATELY 80 DEGREES TO EACH SIDE AND ABOUT 30 DEGREES UP AND DOWN. (REFERENCE DETAILS B AND C) BE SURE TO READ AND FOLLOW ALL MANUFACTURERS SAFETY PRECAUTIONS. THIS MUST BE DONE SO THE COUPLER WILL BE PRESENTED WITH A STRAIGHT PULL BY THE HOSE IN THE EVENT OF A SITUATION WHERE THE NURSE TANK COMES FREE OF ITS ATTACHMENT TO THE TOOLBAR.

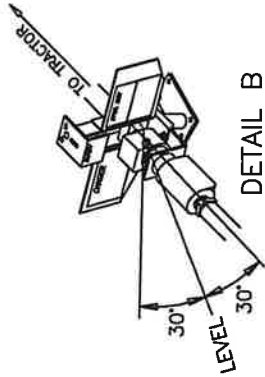

MUST SWIVEL A MINIMUM OF
30° UP AND 30° DOWN
(VERTICAL MOVEMENT)
(SHOWN 30° DOWN)

IF THE COUPLER CANNOT SWIVEL PROPERLY, THE HOSE MAY PULL AT AN ANGLE WHICH CAUSES THE SEPARATION FORCE TO INCREASE GREATLY AND MAY BIND THE COUPLER PREVENTING SEPARATION. SINCE PULL AWAY EVENTS OFTEN OCCUR DURING A TURN, THE ABILITY OF THE COUPLER TO SWIVEL IS DESCRIBED AS CRITICAL TO THE OPERATION OF THE BREAK-AWAY COUPLING DEVICE.

ALL PIPING AND VALVES IN THE SYSTEM SHOULD BE ABLE TO WITHSTAND A PULL FORCE GREATER THAN 450 POUNDS. READ ALL MANUFACTURERS OPERATING INSTRUCTIONS AND DECALS BEFORE WORKING WITH ANY CONNECTIONS. READ AND FOLLOW THE BREAK-AWAY DEVICE MANUAL FOR CONNECTION AND DISCONNECTION PROCEDURES AND SAFETY PRECAUTIONS.

SAFETY

WHEN WORKING WITH NH3 CONNECTIONS, WEAR PROTECTIVE CLOTHING, GOGGLES AND GLOVES AND HAVE EMERGENCY WATER AVAILABLE FOR WASHING. ALWAYS STAND ON THE UPWIND SIDE AND AVOID BREATHING IN ANY CHEMICAL VAPORS.

MAINTENANCE

BEFORE EACH USE, VISUALLY INSPECT THE BREAK-AWAY COUPLING FOR LEAKS, DAMAGED OR BROKEN COMPONENTS. ALSO CHECK THAT THE NH3 STAND OPERATES PROPERLY, THAT THE VERTICAL SPRING IS NOT BROKEN, AND ALLOWS FREE SWIVEL MOVEMENT AS SHOWN IN DETAILS B & C AND SPRINGS BACK INTO THE NORMAL OPERATING POSITION AS SHOWN IN DETAIL A. CHECK AND TIGHTEN ALL HARDWARE AS NEEDED. THE BREAK AWAY COUPLING DEVICE SHOULD BE FULLY INSPECTED AT LEAST ONCE A YEAR OR REPLACED OR REPAIRED AS REQUIRED. REPLACE ENTIRE COUPLER BASED ON EXPIRATION DATES ON COUPLER DECALS.

MANUALLY DISCONNECT OR RECONNECT INSTRUCTIONS

DANGER! DO NOT DISCONNECT OR RECONNECT UNDER PRESSURE

READ AND UNDERSTAND THE BREAK-AWAY COUPLING DEVICE MANUFACTURERS INSTRUCTIONS, WARNINGS AND SPECIFICATIONS BEFORE ATTEMPTING TO MANUALLY DISCONNECT OR RECONNECT THE COUPLING. FOLLOW THE BREAK-AWAY COUPLING DEVICE MANUFACTURERS BLEEDING THE SYSTEM PROCEDURES LISTED IN THEIR OWNERS MANUAL OR ON THEIR DANGER DECAL. ALWAYS WEAR PROTECTIVE GOGGLES, GLOVES, CLOTHING AND HAVE EMERGENCY WATER AVAILABLE FOR WASHING WHEN WORKING WITH NH3. ALWAYS DIRECT BLEEDS AWAY FROM YOUR FACE OR BODY.

WARNING

FAILURE TO READ AND UNDERSTAND THE INSTRUCTIONS CONTAINED IN THESE INSTALLATION, OPERATION, AND MAINTENANCE INSTRUCTIONS COULD LEAD TO PROPERTY DAMAGE, SERIOUS INJURY OR DEATH! READ AND UNDERSTAND THE BREAK-AWAY COUPLING AND NH3 STAND MANUFACTURERS MANUALS COMPLETELY.

SAFETY LIGHT KIT FOR TOOLBARS

P/N: 47999789

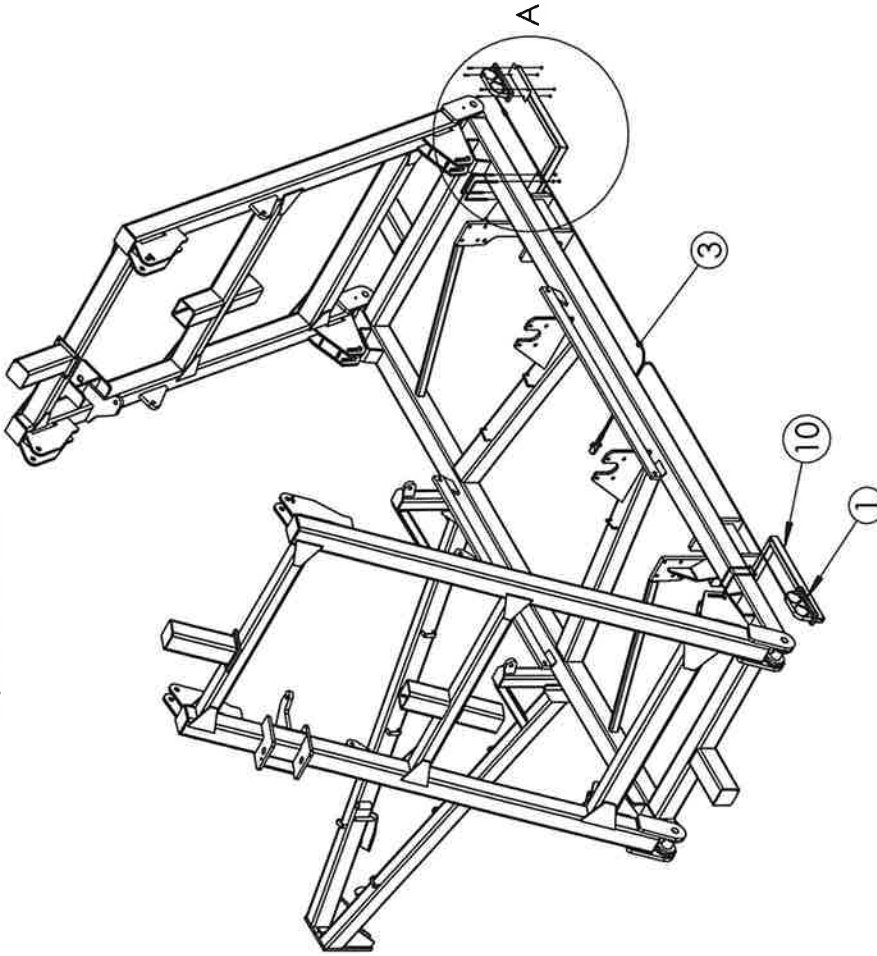

AMBER REPLACEMENT LENS PN 802650
RED REPLACEMENT LENS PN 802651

ITEM NO.	PART NUMBER	DESCRIPTION	QTY.
1	54209-008	DUAL LAMP ASSY, LH	1
2	54209-022	DUAL LAMP ASSY, RH	1
3	71675	35' HD CABLE WITH 7 PIN PLUG	1
4	47009986	U-BOLT, 3/8-16NC.	4
5	18891200	LOCKWASHER, 3/8 ZC	8
6	18436800	NUT 3/8 NCZC	8
7	18055724	BOLT HX CAP G5 NCZC 1/4 X 1 1/4	8
8	18495700	NUT HX SER FLG 1/4 NC ZC	8
9	47009789	LITE BRACKET, LH	1
10	47009790	LITE BRACKET, RH	1
11	504560	NYLON TIE STRAP	5

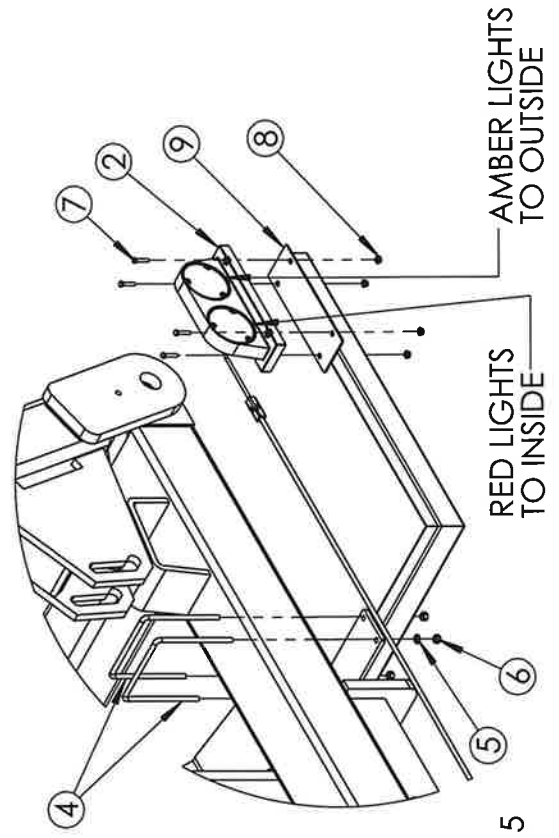

DETAIL A
SCALE 1 : 15

DOUBLE DISK SEALER ASSEMBLY

WITH FLOATING ARMS

ASSEMBLY P.N. 40034010 SMOOTH 18" DISK
40034011 NOTCHED 18" DISK

KIT TO CONVERT
EXISTING 18 INCH DISK SEALER
TO FLOATING ARM STYLE
P.N. 47994993
INCLUDES ITEMS 1 TO 10

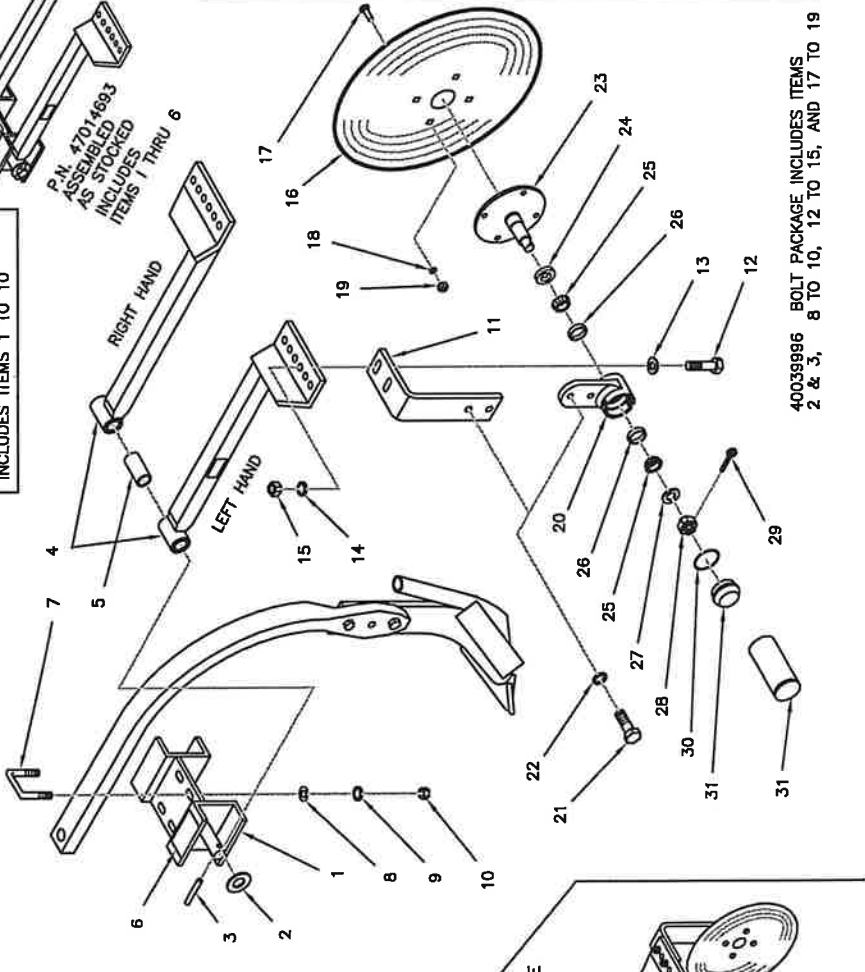
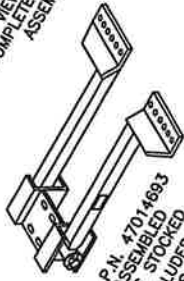
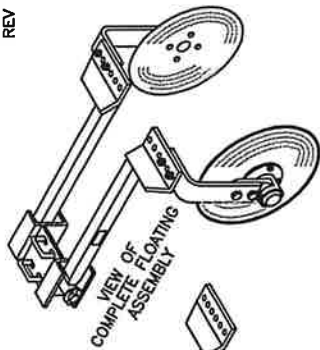

CASE/DMI
SHANK
OPTION

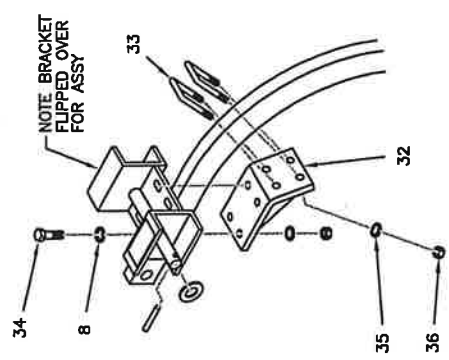

HOLE MOUNTS TO CASE
OR DMI BUNDLE

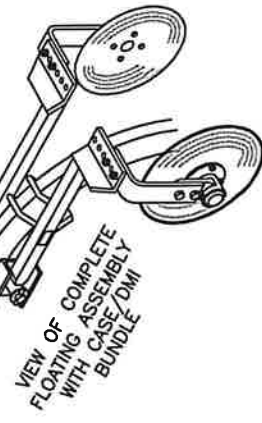

ITEM	PART NO.	DESCRIPTION	QTY
1	47004693	MOUNTING BRACKET (W/DECAL)	1
2	18952200	FLAT WASHER, 1" SAE, ZC	2
3	18511036	EXPANSION PIN, 3/8 X 2, 1/4	2
4	47004697	PIVOT ARM, L.H. (INCL. ITEM 5)	1
5	47004698	PIVOT ARM, R.H. (INCL. ITEM 5)	1
6	470039952	FIBER BUSHING, (1" I.D. X 2, 1/2)	2
7	97445303	DECAL, "AG SYSTEMS" SMALL	2
8	47008396	U-BOLT, 1/2-13NC. (2' SHANK)	2
9	18611400	FLAT WASHER, 1/2	4
10	18417400	LOCK WASHER, 1/2	4
11	47009621	HEX. NUT, 1/2-13NC.	4
12	18057430	DISK ARM	2
13	18811400	BOLT, 1/2-13NC. X 2	4
14	18811400	LOCK WASHER, 1/2	4
15	18417400	FLAT WASHER, 1/2	4
16	44501810	HEX. NUT, 1/2-13NC.	4
17	18176450	DISK BLADE, SMOOTH EDGE	2
18	18891200	DISK BLADE, NOTCHED EDGE	2
19	18436800	CARRIAGE BOLT, 3/8-16NC. X 1	8
20	47109558	LOCK WASHER, 3/8	8
21	47009558	HEX. NUT, 3/8-16NC.	8
22	18057523	HUB ASSEMBLY COMPLETE	2
23	18891400	HUB WITH CUPS, ITEM 26	4
24	40030328	BOLT, 1/2-20NF, X 1 1/4	4
25	10659	LOCK WASHER, 1/2	2
26	40030325	SPINDLE WITH FLANGE	2
27	10659	GREASE SEAL	2
28	18641800	BEARING CONE	4
29	18486600	BEARING CUP	4
30	18560722	FLAT WASHER, 3/4 SAE (1 1/2 O.D.)	2
31	47999558	SLOTTED NUT 3/4-16NF	2
32	47005502	COTTER PIN 5/32 X 1	2
33	47005502	O-RING DUST SEAL	2
34	47005502	DUST CAP	2
35	47005502	DUST CAP INSTALLATION TOOL (OPTIONAL)	1
36	47005794	FLOATING ARM BRKT CASE/DMI SHANK	1
37	47008397	U-BOLT-AG 3 1/2 X 1 5/16 W	2
38	18057428	BOLT, HEX HD GR5ZC 1/2 X 1 3/4	4
39	18891400	LOCK WASHER, 1/2	4
40	18417400	HEX. NUT, 1/2-13NC.	4

40039986 BOLT PACKAGE INCLUDES ITEMS
2 & 3, 8 TO 10, 12 TO 15, AND 17 TO 19

ASSEMBLY INSTRUCTIONS

DISK COVER SEALER

18 INCH WITH FLOATING ARMS

Your disc cover sealer assembly is partially assembled at the factory. The spindle (item 23) and all hub components are pre-assembled and greased for life.

1. Due to the weight of a complete disk sealer assembly, it is recommended that the disk sealer be assembled to a shank already mounted on a toolbar. Position the mounting bracket (item 1) on the bottom side of the shank (as illustrated) and the u-bolt straddling the top of the shank. The mounting bracket should be located on the flat part of the shank. When using the disk sealer with a "Hi-Trip" spring bundle, position the mounting bracket as far forward on the shank as the spring bundle bracket will allow. Securely tighten the hardware.

2. Position the pivot arm (item 4) left hand and right hand, to the mounting bracket (item 1) and assemble with the washers (item 2) and the expansion pins (item 3).

3. Secure the disk arm (item 11) in a vice and assemble the hub assembly to the arm with the bolts (item 21) and lock washers (item 22). Assemble the disk (item 16) to the spindle flange with the bolts (item 17) and hardware items (18 and 19) There is no difference between the left hand and right hand assemblies.

4. Mount the disk arm assemblies to the pivot arms with the bolts (item 12) and hardware (items 13, 14 and 15) as illustrated with the nut on top of the pivot arm plate. The suggested start-up position would be to mount the disk arm in the holes in the pivot arm plate that are farthest to the outside. The slotted holes in the disk arm provide the angular adjustment for the disk. Position the disks at the desired angle and tighten the hardware securely.

TWIN BALL HITCH MOUNT

85KMONTAGCART
09-17-10

FOR MONTAG STEERABLE CART
ON 8500 AND DMI 5300 TOOLBARS

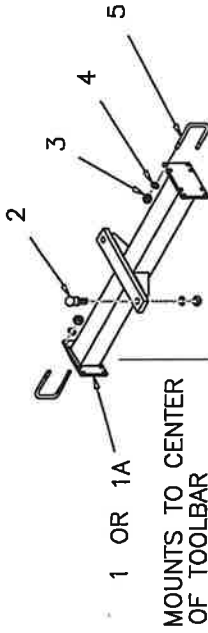

6 AG26 MONTAG CART FIELD HITCH
MOUNTS TO REAR OF MONTAG
STEER CART ONLY

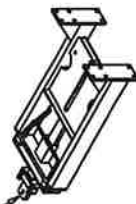

FOR MONTAG CART FIELD HITCH
SERVICE PARTS SEE SEPARATE
ILLUSTRATION "AG26 MONTAG"

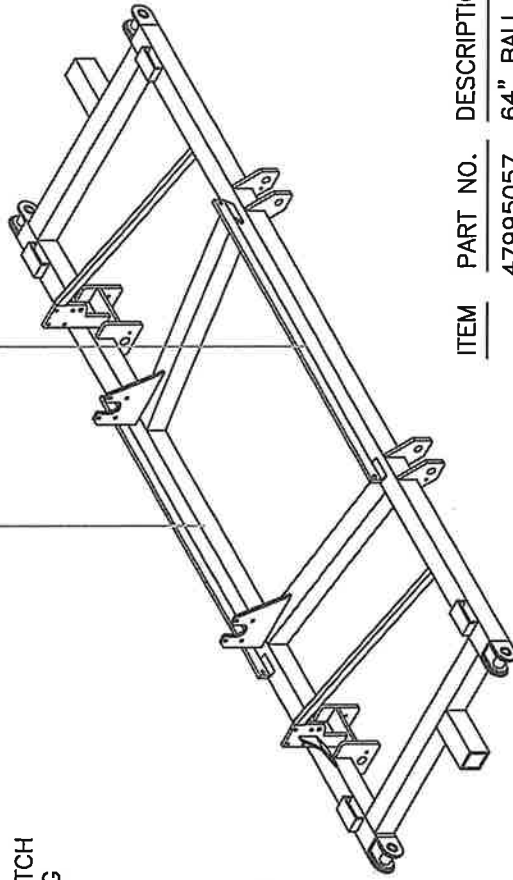

ITEM	PART NO.	DESCRIPTION	QTY
	47995057	64" BALL HITCH ASSY (INCLUDES ITEMS 1 & 3 THRU 5)	1
	47995136	54" BALL HITCH ASSY DMI (INCLUDES ITEMS 1A & 3 THRU 5)	1
1	47015057	64" BALL HITCH WELDT (FITS 8500 ONLY)	1
1A	47005136	54" BALL HITCH WELDT (FITS DMI 5300 ONLY)	1
2	47002516	HITCH BALL W HARDWARE (included with Montag Autosteer cart)	2
3	18417900	HEXNUT, 5/8	16
4	18891600	LOCKWASHER, 5/8	16
5	47009847	U-BOLT, 5/8 (8500)	8
	47007083	U-BOLT, 5/8 (DMI)	8

AG26 FIELD HITCH ASSEMBLY

FOR MONTAG STEERING CART

7 & 10 TON HITCH FITS 8 X 8 & 8 X 12 TUBULAR FRAME
 7 TON ONLY HITCH (OBSOLETE) FITS 8 X 8 TUBULAR FRAME
 NOTE: 7 TON ONLY HITCH OBSOLETE DEC 2006

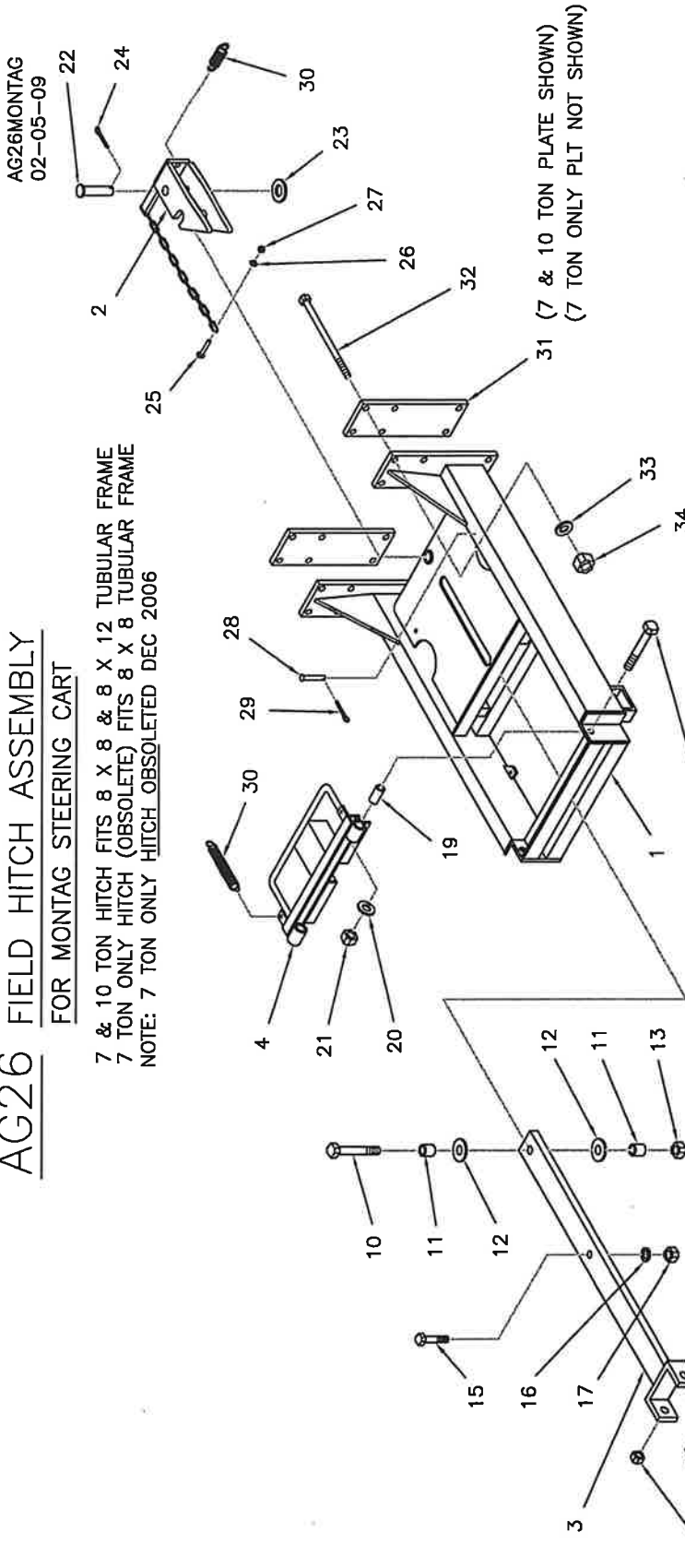

AG26MONTAG
 02-05-09

ITEM	PART NO.	DESCRIPTION	QTY.	ITEM	PART NO.	DESCRIPTION	QTY.
1	40269900	HITCH ASSY (7 TON ONLY) OBS 2006	1	15	18058430	BOLT, 3/4-10 NC. X 2	1
2	40268599	HITCH ASSY (7 & 10 TON) COMPLETE	1	16	18891800	LOCKWASHER, 3/4	1
3	40269901	HITCH ASSY (7 TON ONLY) LESS MTG	1	17	18418400	HEX. NUT, 3/4-10NC.	1
4	40268598	HITCH ASSY (7 & 10 TON) LESS MTG	1	18	18057940	BOLT, 5/8-11NC. X 3 1/2	2
5	47005153	BOLTS OBSOLETE 2006	1	19	47008877	PIVOT BUSHING	2
6	47005227	BOLTS INCLUDES ITEMS, 1 THRU 30	1	20	18851600	FLATWASHER, 5/8X10WD.I.D. SAE.	2
7	47008852	MAIN FRAME, 7 TON ONLY	1	21	18457900	LOCKNUT, 5/8-11NC.	2
8	47008853	MAIN FRAME, 7 & 10 TON MONTAG	1	22	18541551	CATCH PIVOT PIN	1
9	47008854	DRAWBAR CATCH	1	23	18842200	FLATWASHER, 1", SAE X 4	1
10	47008854	DRAWBAR LOCK	1	24	18560826	COTTER PIN, 3/16 X 1 1/2	1
11	47008914	DRAWBAR HITCH, (SEE NOTE 1)	1	25	18055722	BOLT, 1/4-18NC. X 1	1
12	47008918	DRAWBAR HITCH, (SEE NOTE 1)	1	26	18891000	LOCKWASHER, 1/4 NOM. I.D.	1
13	47008918	DRAWBAR HITCH, (SEE NOTE 1)	1	27	18435700	HEX. NUT, 1/4-18NC.	1
14	47008918	DRAWBAR HITCH, (SEE NOTE 1)	1	28	18541147	CLEVIS PIN, 5/16 X 2 1/4	1
15	47008918	DRAWBAR HITCH, (SEE NOTE 1)	1	29	18560622	COTTER PIN, 1/8 X 1	1
16	47008918	DRAWBAR HITCH, (SEE NOTE 1)	1	30	000018	EXTENSION SPRING	3
17	47008918	DRAWBAR HITCH, (SEE NOTE 1)	1	31	47005155	CLAMPING PLATE (7 TON ONLY)	2
18	47008918	DRAWBAR HITCH, (SEE NOTE 1)	1	32	47005229	CLAMPING PLATE (7 & 10 TON)	2
19	47008918	DRAWBAR HITCH, (SEE NOTE 1)	1	33	40269998	BOLT PKG. INCL. ITEMS 32 THRU 34	8
20	47008918	DRAWBAR HITCH, (SEE NOTE 1)	1	34	18058486	BOLT HEX 3/4-10 X 11 GR 5	8
21	47008918	DRAWBAR HITCH, (SEE NOTE 1)	1		18891800	LOCKWASHER, 3/4 NOM. I.D.	8
22	47008918	DRAWBAR HITCH, (SEE NOTE 1)	1		18418400	HEX. NUT, 3/4-10NC.	8
23	47008918	DRAWBAR HITCH, (SEE NOTE 1)	1				
24	47008918	DRAWBAR HITCH, (SEE NOTE 1)	1				
25	47008918	DRAWBAR HITCH, (SEE NOTE 1)	1				
26	47008918	DRAWBAR HITCH, (SEE NOTE 1)	1				
27	47008918	DRAWBAR HITCH, (SEE NOTE 1)	1				
28	47008918	DRAWBAR HITCH, (SEE NOTE 1)	1				
29	47008918	DRAWBAR HITCH, (SEE NOTE 1)	1				
30	47008918	DRAWBAR HITCH, (SEE NOTE 1)	1				
31	47008918	DRAWBAR HITCH, (SEE NOTE 1)	1				
32	47008918	DRAWBAR HITCH, (SEE NOTE 1)	1				
33	47008918	DRAWBAR HITCH, (SEE NOTE 1)	1				
34	47008918	DRAWBAR HITCH, (SEE NOTE 1)	1				

BREAK-AWAY COUPLING DEVICE (BACD) SWING ARM ASSEMBLY FOR NH3 TOOLBARS

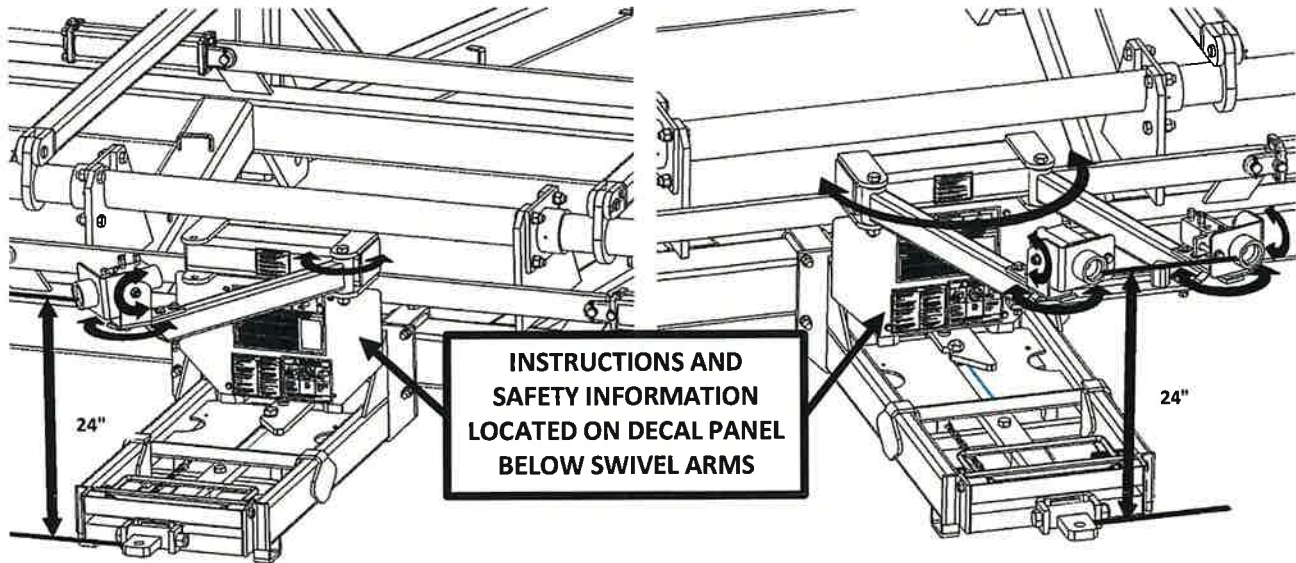

Figure 1: Single Swing Arm

Figure 2: Dual Swing Arms

The purpose of the break-away coupling device (BACD) is to provide an automatic valve closure to limit the potential hazard of NH₃ released to the atmosphere in the event of a trailing nurse tank becoming inadvertently unhitched and disconnected from the toolbar.

The Heartland Ag Systems Equipment swing arm style NH₃ stand securely mounts the BACD to the toolbar while allowing it to freely swivel over 80° left to right (horizontally) and 30° up and down (vertically) in each direction as well as positions the coupler 24" above the nurse tank hitch connection point as shown above in figures 1 and 2. "Super Shooter" style NH₃ stands were discontinued in 2015 and should be updated to the swing arm style NH₃ stands.

Follow the BACD manufacturer's installation, maintenance, and operation recommendations. Refer to your specific toolbar model owners manual for NH₃ stand assembly detail and parts requirements. Before each use visually inspect the BACD for leaks, damage, or loose components. Also check that the NH₃ stand operates properly and all decals are in place and can be easily read. Be sure to follow all manufacturer's safety precautions - **FAILURE TO READ AND UNDERSTAND THE SAFETY INSTRUCTIONS COULD LEAD TO PROPERTY DAMAGE, SERIOUS INJURY, OR DEATH.** The BACD must be fully inspected annually and repaired or replaced as required.

When working with NH₃ connections wear protective clothing, goggles, and gloves and have emergency water available. Always stand on the upwind side and avoid breathing in chemical vapors. **DO NOT DISCONNECT OR RECONNECT UNDER PRESSURE.**

The links and QR Codes below direct you to the MN Department of Agriculture BACD parts and installation videos.

NH₃ Break-Away Coupling Device Installation
(<https://www.youtube.com/watch?v=0EPNeZwvCE>)



NH₃ Break-Away Coupling Device Parts
(<https://www.youtube.com/watch?v=Rn1Ro8jWh3M>)



The links and QR codes below direct you to the Continental and Squibb Taylor BACD operating/installation instructions.

Continental B-SWV-125 & B-SWV-150-G Couplers
(<http://www.continentalnh3.com/pdfs/B-SWV-125%20150%20G.pdf>)



Squibb Taylor Flo-Max Couplers
([http://www.squibbtaylor.com/uploaded/FM1.25-1000%20\(2008\).pdf](http://www.squibbtaylor.com/uploaded/FM1.25-1000%20(2008).pdf))



