

# ASSEMBLY & MOUNTING INSTRUCTIONS FOR BRUTE II

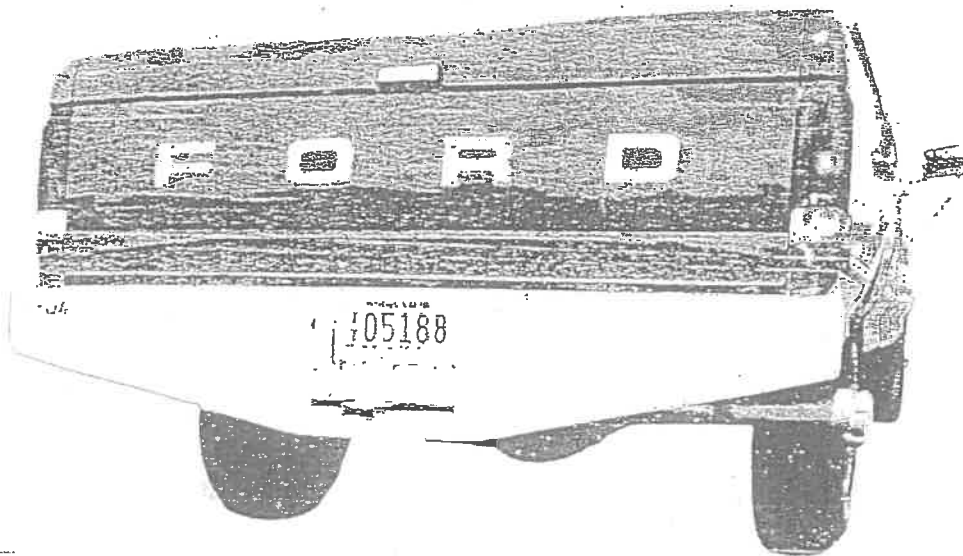
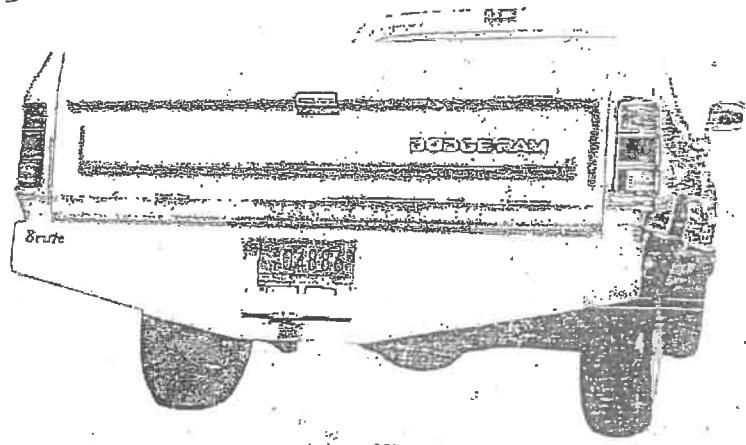
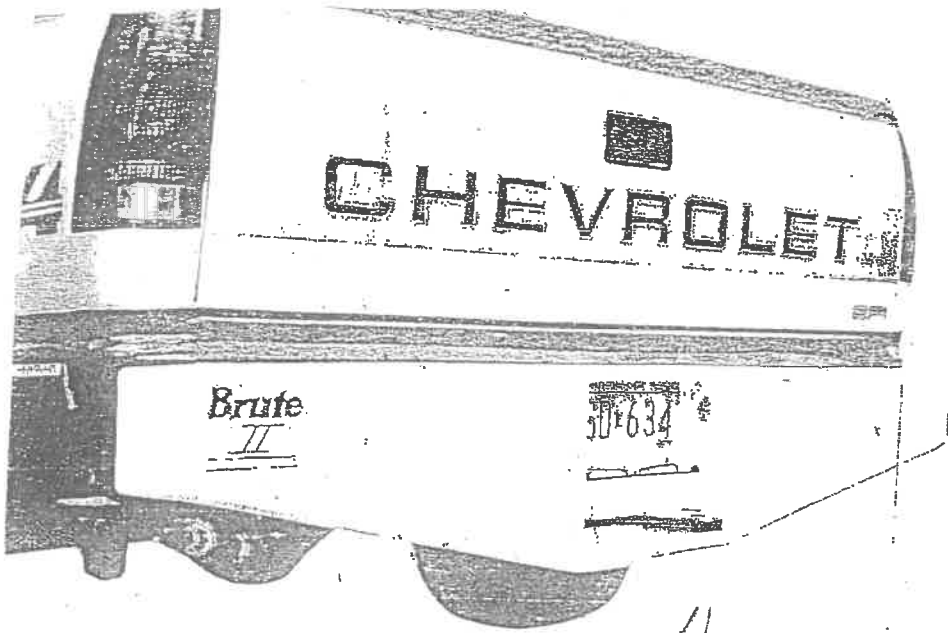

# BRUTE I I BUMPER (AG1)

## AND AG5 LONG & SHORT WITH BOLT-ON FACE

FROM DATES AS NOTED

BMPRIS003  
03/02/21

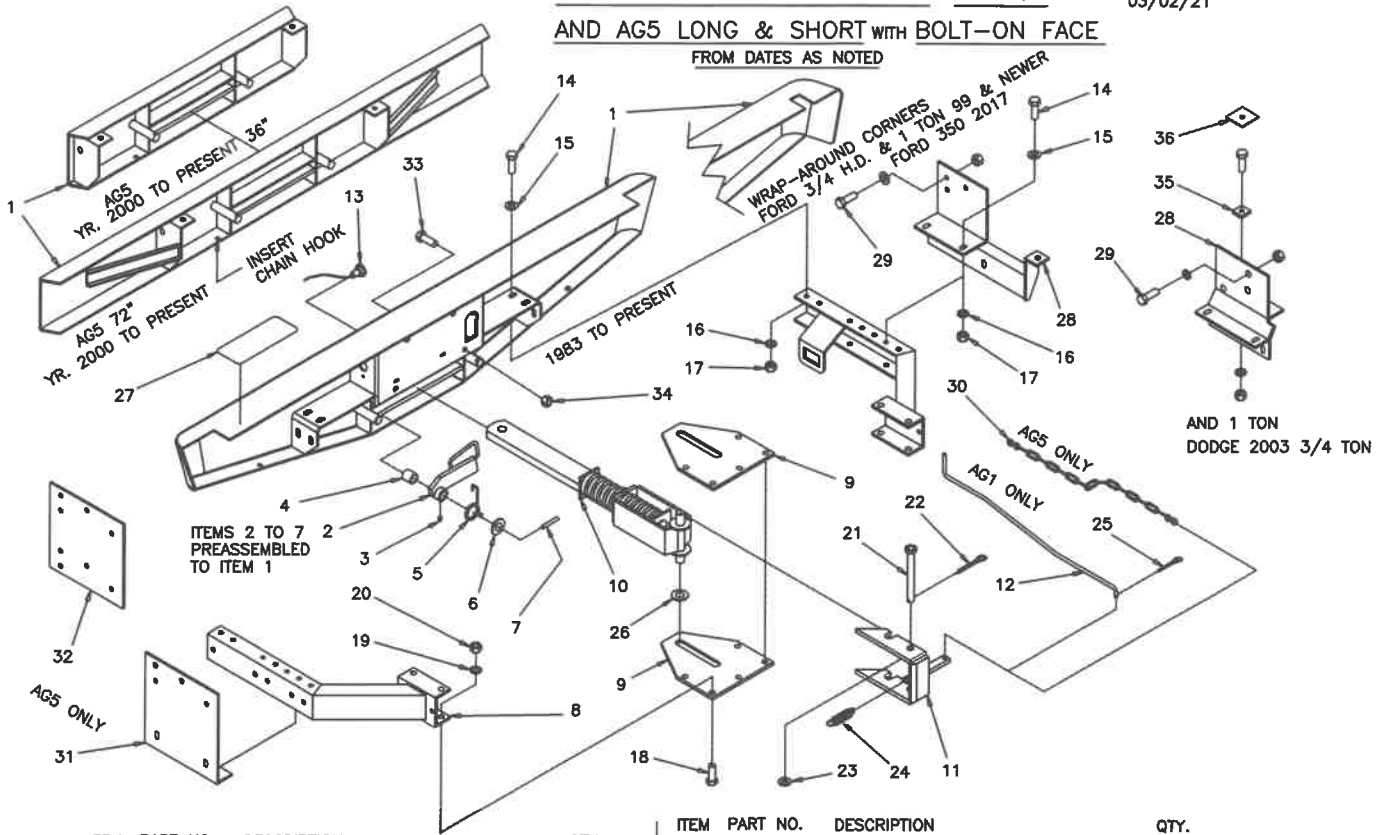

ITEM	PART NO.	DESCRIPTION	QTY.
ALL BUMPER FACE ASSEMBLIES INCLUDE THE ARM LOCK ASSEMBLIES (ITEMS 2 TO 7) CHOOSE			
1	47109155	BUMPER FACE, ASSY. WHITE 73" USE WITH BRKT. SETS, A, B, C, D, E, F, G, H, K, M, N, P, Q, R, T, U, V, W, OR X	1
	47109256	BUMPER FACE, ASSY. CHROME 73" USE WITH BRKT. SETS, A, C, D, E, F, G, H, K, M, N, P, Q, R, T, U, V, or W	1
	47109257	BUMPER FACE, ASSY. CHROME 74" W/WRAP-AROUND CORNERS USE WITH BRKT. SETS B, OR X ONLY	1
	47209260	BUMPER FACE, ASSY. WHITE 72" AG5 ONLY USE WITH BRKT. SETS, (ALL)	1
	47209407	BUMPER FACE, ASSY. WHITE 36" AG5 ONLY USE WITH BRKT. SETS, "I" ONLY	1
2	47109063	ARMLOCK ASSEMBLY, L.H. (AG1 ONLY)	1
	47109064	ARMLOCK ASSEMBLY, R.H. (AG1 ONLY)	1
2	47109148	ARMLOCK ASSEMBLY, L.H. (AG5 ONLY)	1
	47109149	ARMLOCK ASSEMBLY, R.H. (AG5 ONLY)	1
ITEMS 3 AND 4 ARE PREASSEMBLED TO ITEM 2			
3	18901805	GREASE ZERK, STRAIGHT	2
4	47101031	BRASS BUSHING	2
5	47101149	TORSION SPRING, LEFT	1
5	47101150	TORSION SPRING, RIGHT	1
6	18852200	FLATWASHER, 1 INCH SAE (ZP)	2
7	18511034	ROLL PIN, 1/4 X 2 1/2	2
	47109002	STANDARD HARDWARE PACKAGE INCLUDES ITEMS 8 TO 26	1
8	47109150	SIDE BRACE WELDMENTS (1RH & 1LH)	2
9	47102020	TOP PLATE	2
10	47109455	DRAWBAR ASSEMBLY	1
11	47109419	HOOK ASSEMBLY	1
12	47102420	PULL HANDLE, AG1 ONLY (SEE ITEM 30)	1
13	47105484	LIGHT ASSEMBLY	1
	47005823	ASSEMBLY BOLT PACKAGE INCLUDES ITEMS 14 TO 20, AND 22 & 23 AND 25 & 26 AND 33 & 34	1
14	18057424	BOLT, 1/2-13NC. X 1 1/4	14
15	18811400	FLATWASHER, 1/2 INCH	14
16	18891400	LOCKWASHER, 1/2 INCH	14
17	18417400	HEX. NUT, 1/2-13NC.	14
18	18057926	BOLT, 5/8-11NC. X 1 1/2	8
19	18891600	LOCKWASHER, 5/8 INCH	8
20	18417900	HEX. NUT 5/8-11NC.	8
21	47109056	HOOK PIN	1
22	18561026	COTTER PIN, 1/4 X 1 1/2	1
23	18811800	FLATWASHER, 3/4 INCH	1
24	47106043	EXTENSION SPRING	1
25	18560722	COTTER PIN, 5/32 X 1	1
26	18852200	FLATWASHER, 1 INCH SAE (ZP)	1
27	47109999	SAFETY GRIP PAD	2
28	47109739	MOUNTING BRACKETS, SET "A" for CHEV/GMC, '88 THRU '98, 1/2, 3/4, 1 TON and CK-CHEV/GMC, 99 & 00, OLD CAB 3/4, 1 TON	1
28	47108822	MOUNTING BRACKETS, SET "B" for FORD 3/4 H.D. & 1 TON 1999 to 2016	1

ITEM	PART NO.	DESCRIPTION	QTY.
28	47102431	MOUNTING BRACKETS, SET "C" FOR CHEV, GMC, IHC, '74-87, 1/2, 3/4, 1 TON	1
28	47109433	MOUNTING BRACKETS, SET "D" for DODGE, THRU 1993	1
28	47107416	MOUNTING BRACKETS, SET "E" for DODGE S.B. '94 THRU '97, 1/2, 3/4 TON and DODGE Shortbox 1/2 TON thru 2001	1
28	47109429	MOUNTING BRACKETS, SET "F" FOR FORD '80 THRU '96, 1/2, 3/4, 1 TON AND FORD '97 & '98, HD. 3/4, 1 TON	1
28	47108641	MOUNTING BRACKET, SET "G" FOR DODGE Shortbox HD. 3/4 TON Thru 2002	1
28	47109423	MOUNTING BRACKETS, SET "H" for FORD, 1973 THRU 1979	1
28	47108198	MOUNTING BRACKETS, SET "K" for FORD 1 '97-'99 (1/2T & 3/4T LD) & 00 - 03 1/2 TON	1
28	47109193	MOUNTING BRACKETS, SET "M" for DODGE, 1994 thru 02 3/4 & 1 TON and '94 TO 2002 1/2 TON	1
28	47109901	MOUNTING BRACKETS, SET "N" for CHEV. SHORT BOX, 1988 THRU '98	1
28	47109044	MOUNTING BRACKETS, SET "P" for CHEV/GMC (ANY BOX) '99 NEW CAB and 2001 to 2010 1/2 & 3/4 TON LD	1
28	47109494	MOUNTING BRACKETS, SET "Q" for CHEV 3/4 TON H.D. SHORT BOX, 2001 THRU 2010	1
28	47109523	MOUNTING BRACKETS, SET "R" for CHEV 3/4 TON H.D. LNG BX & 1 TON, '01 THRU 2010	1
28	47109900	MOUNTING BRACKETS, SET "T" for DODGE 3/4 & 1 TON LONG BOX 2003 & NEWER INCLUDES ITEMS 35 AND 36	1
28	47109956	MOUNTING BRACKETS, SET "U" FOR DODGE 2003 and NEWER 3/4 & 1 TON SHORT BOX INCLUDES ITEMS 35 & 36	1
28	47105548	MOUNTING BRACKETS, SET "V" FOR CHEV 3/4 TON 2500H.D. SHORT BOX, 2011 & NEWER	1
28	47105581	MOUNTING BRACKETS, SET "W" FOR GMC CHEV 3/4 TON 2500H.D. LONG BOX, 2011 & NEWER	1
28	47103524	MOUNTING BRACKETS, SET "X" FOR FORD F350, 2017 & NEWER	1
28	71316	MOUNTING BRACKETS & HARDWARE GMC HD 2020 & NEWER	1
29		MOUNTING BOLT PACKAGE SEE NEXT PAGE FOR CONTENTS AND APPLICATIONS.	1
ITEMS 30 TO 32 ARE USED ON AG5 ONLY			
30	47109774	PULL CHAIN WITH "S" HOOKS	1
31	47109406	MOUNTING BRACKETS, SET "I" for ALL 34" WIDE FRAMES AG5 ONLY	1
32	47109135	"SET" B" EXTENSION PLATES FOR "I" BRACKETS, AG5 ONLY	1
33	18706426	LICENSE PLATE HARDWARE MACHINE SCREW, 1/4-20NC. X 3/4	2
34	18495700	FLANGE NUT, 1/4-20NC.	2
ITEMS 35 AND 36 ARE PART OF BRACKET SET "T" & "U"			
35	47109903	TOP FRAME WASHER	2
36	47109904	BOX SPACER WASHER	2

# BRUTE I I BUMPER

AND AG5 BOLT-ON

## MOUNTING BOLT PACKAGE

BMPRBLT03  
REV 08/30/17

PART NO.	DESCRIPTION	QTY.
47005825	BOLT PACKAGE COMPLETE, use with MOUNTING BRKTS SETS, A & D & 1 for CHEV/GMC, '88 THRU '88, 1/2, 3/4, 1 TON and CK-CHEV/GMC, '99 & OD, OLD CAB 3/4, 1 TON for DODGE, THRU 1993 and ALL AG7 BUMPERS	
18057426	BOLT, 1/2-13NC. X 1 1/2	8
18417400	HEX. NUT, 1/2-13NC.	8
18891400	LOCKWASHER, 1/2	8

47008822	BOLT PACKAGE COMPLETE, use with MOUNTING BRKTS SETS, "B" for FORD 1999 3/4 TON H.D. OR 1 TON	
18057426	BOLT, 1/2-13NC. X 1 1/2	2
18891400	LOCKWASHER, 1/2	2
18417400	HEX. NUT, 1/2-13NC.	2
18057741	BOLT, 9/16-12NC. X 1 1/2	4
18891500	LOCKWASHER, 9/16	4
18417600	HEX. NUT, 9/16-12NC.	4

47005826	BOLT PACKAGE COMPLETE, use with MOUNTING BRKTS SETS, C and N for CHEV, GMC, IHC, '74-87, 1/2, 3/4, 1 TON and for CHEV. SHORT BOX, 1988 THRU '98	
18057426	BOLT, 1/2-13NC. X 1 1/2	8
18417400	HEX. NUT, 1/2-13NC.	8
18891400	LOCKWASHER, 1/2	8
18851400	FLATWASHER, 1/2	4

47006824	BOLT PACKAGE COMPLETE, use with MOUNTING BRKTS SETS, E and H for DODGE S.B. '94 THRU '97, 1/2, 3/4 TON and DODGE S.B. '98 & NEWER 1/2 TON for FORD, 1973 THRU 1979	
18057926	BOLT, 5/8-11NC. X 1 1/2	6
18417900	HEX. NUT, 5/8-11NC.	6
18891600	LOCKWASHER, 5/8	6
18057426	BOLT, 1/2-13NC. X 1 1/2	2
18417400	HEX. NUT, 1/2-13NC.	2
18891400	LOCKWASHER, 1/2	2
18811400	FLATWASHER, 1/2	2

47004825	BOLT PACKAGE COMPLETE, use with MOUNTING BRKTS SETS, "P" CHEV/GMC (ANY BOX) '99 NEW CAB	
18057426	BOLT, 1/2-13NC. X 1 1/2	10
18417400	HEX. NUT, 1/2-13NC.	10
18891400	LOCKWASHER, 1/2	10

47005824	BOLT PACKAGE COMPLETE, use with MOUNTING BRKTS SETS, "F" for FORD '80 THRU '96, 1/2, 3/4, 1 TON and FORD '97 & '98, HD. 3/4, 1 TON	
18057426	BOLT, 1/2-13NC. X 1 1/2	2
18417400	HEX. NUT, 1/2-13NC.	2
18891400	LOCKWASHER, 1/2	2
18851400	FLATWASHER, 1/2	2
18057926	BOLT, 5/8-11NC. X 1 1/2	2
18417900	HEX. NUT, 5/8-11NC.	2
18891600	LOCKWASHER, 5/8	2
18811600	FLATWASHER, 5/8	2
18057777	BOLT, 14MM X 35MM X 2	4
18057778	HEX. NUT, 14MM X 2	2
18891500	LOCKWASHER, 9/16	4

NO BOLT PACKAGE REQ'D FOR MOUNTING BRKTS "X", FOR FORD F350 2017 & NEWER  
\*\*USE EXISTING VEHICLE HARDWARE\*\*

PART NO.	DESCRIPTION	QTY.
47007824	BOLT PACKAGE COMPLETE, use with MOUNTING BRKTS SETS, "G" for DODGE S.B. '88 & NEWER HD. 3/4 TON	
18057926	BOLT, 5/8-11NC. X 1 1/2	8
18417900	HEX. NUT, 5/8-11NC.	8
18891600	LOCKWASHER, 5/8	8
18057426	BOLT, 1/2-13NC. X 1 1/2	2
18417400	HEX. NUT, 1/2-13NC.	2
18891400	LOCKWASHER, 1/2	2
18851400	FLATWASHER, 1/2	2

47005831	BOLT PACKAGE COMPLETE, use with MOUNTING BRKTS SETS, "K" for FORD, '87-'89 (1/2T & 3/4T LD) & '00 1/2 TON	
18057426	BOLT, 1/2-13NC. X 1 1/2	6
18417400	HEX. NUT, 1/2-13NC.	6
18891400	LOCKWASHER, 1/2	6
18851400	FLATWASHER, 1/2	6

47006825	BOLT PACKAGE COMPLETE, use with MOUNTING BRKTS SETS, "M" for DODGE, 1994 & NEWER	
18056426	BOLT, 5/16-18NC. X 1 1/2	2
18406400	HEX. NUT, 5/16-18NC.	2
18891110	LOCKWASHER, 5/16	2
18811100	FLATWASHER, 5/16	2
18057926	BOLT, 5/8-11NC. X 1 1/2	6
18417900	HEX. NUT, 5/8-11NC.	6
18891600	LOCKWASHER, 5/8	6

47009494	BOLT PACKAGE COMPLETE, use with MOUNTING BRKTS SETS, "Q" & "V" for CHEV 2001 HD. S.B. 1/2 TON	
18057741	BOLT, 9/16-12NC. X 1 1/2	4
18891500	LOCKWASHER, 9/16	4
18417600	HEX. NUT, 9/16-12NC.	4
18057930	BOLT, 5/8-11NC. X 2	4
18417900	HEX. NUT, 5/8-11NC.	4
18891600	LOCKWASHER, 5/8	4
18057426	BOLT, 1/2-13NC. X 1 1/2	8
18417400	HEX. NUT, 1/2-13NC.	8
18891400	LOCKWASHER, 1/2	8

47999523	BOLT PACKAGE COMPLETE, use with MOUNTING BRKTS SETS, "R" for CHEV 2001 HD. S.B. 1/2 TON	
18057741	BOLT, 9/16-12NC. X 1 1/2	4
18891500	LOCKWASHER, 9/16	4
18417600	HEX. NUT, 9/16-12NC.	4
18057930	BOLT, 5/8-11NC. X 2	6
18417900	HEX. NUT, 5/8-11NC.	6
18891600	LOCKWASHER, 5/8	6
18057426	BOLT, 1/2-13NC. X 1 1/2	8
18891400	LOCKWASHER, 1/2	8
18417400	HEX. NUT, 1/2-13NC.	8

47009900	BOLT PACKAGE COMPLETE, use with MOUNTING BRKTS SETS, "T" & "U" for DODGE 2003 3/4 & 1 TON LG. & SHT BOX	
18057426	BOLT, 1/2-13NC. X 1 1/2	2
18891400	LOCKWASHER, 1/2	2
18417400	HEX. NUT, 1/2-13NC.	2
18058443	BOLT, 3/4-10NC. X 4	6
18891800	LOCKWASHER, 3/4	6
18418400	HEX. NUT, 3/4-10NC.	6

47005581	BOLT PACKAGE COMPLETE, use with MOUNTING BRKT SET "W" for GMC/CHEV 3/4 2500H.D. LB 2011 & newer	
18057426	BOLT, 1/2-13NC. X 1 1/2	8
18057741	BOLT, 9/16-12NC. X 1 1/2	4
18057930	BOLT, 5/8-11NC. X 2	6
18417400	HEX. NUT, 1/2-13NC.	8
18417600	HEX. NUT, 9/16-12NC.	4
18417900	HEX. NUT, 5/8-11NC.	6
18851400	WASHER, FLAT 1/2 SAE ZC	4
18891400	LOCKWASHER, 1/2	8
18891500	LOCKWASHER, 9/16	4
18891600	LOCKWASHER, 5/8 ZC	6

# BRUTE II BUMPER HITCH ASSEMBLY AND MOUNTING INSTRUCTIONS

BMPRINST03  
rev 08/30/17

- (for Dodge 2002 1/2 ton and Dodge 2003 3/4 & 1 ton see step 11)
- STEP 1, Unpack the boxes to determine that all parts needed are on hand.  
NOTE: Items 2 to 7 are preassembled to item 1.
- STEP 2, Select a smooth level surface to assemble your Brute II hitch. Position one top plate (item 9) with the tapered end facing away from you.
- STEP 3, Place the drawbar assembly (item 10) on the plate with the vertical pin in the slot and the solid end of the bar facing away from you.
- STEP 4, Position the side brace weldment "set" (item 8) on the top plate and assemble with the bolts (item 18) and hardware (items 19 & 20) finger tight only. Place the second plate (item 9) on this assembly and fasten with the bolts (item 18) and hardware (items 19 & 20) finger tight only. NOTE: The slotted bracket on the brace should be pointing downward.
- STEP 5, Position the hook assembly (item 11) over the top plates and line up the 3/4 inch holes. Slide the washer (item 26) between the upper top plate and the hook assembly and install the pin (item 21) and fasten with the cotter pin (item 22).
- STEP 6, Attach the spring (item 24) to the hook assembly and a hole provided in the brace assembly (item 8).
- STEP 7, Mount the bumper assembly (item 1) to the side brace assemblies with the bolts (item 14) and hardware (items 15, 16, & 17) snug only.
- STEP 8, Tighten securely the 5/8 inch bolts and hardware previously installed finger tight. Reference step 4.
- STEP 9, Position the pull handle (item 12) through the bumper face and attach it to the hook assembly. Secure with the cotter pin (item 25). Check for free movement. If binding is evident, loosen the assembly hardware and realign the components. Retighten this hardware and securely tighten the hardware on the bumper face.  
NOTE: For AG5 this is a pull chain (item 30).
- STEP 10, Assemble the mounting brackets (item 28) to the side brace assemblies with the bolts (item 14) and hardware (items 15, 16 & 17) finger tight only. These mounting brackets vary in shape and size for different makes, models, and years of vehicles. For normal applications there is one hole open between the bumper and the mounting bracket. This also varies on makes, models, and years. All brackets (item 28) mount to the side braces (item 8) in two directions. Install bolts through the top and sides or the bottom and sides of the side braces.
- STEP 11, Remove the existing bumper and tire carrier bracket from your vehicle.  
SPECIAL INSTRUCTIONS for Dodge 2002 1/2 ton and Dodge 2003 3/4 ton and 1 ton.  
Remove (6) of the (8) bolts that mount the box to the chassis. Remove all the bolts that hold the factory installed hitch assembly in place. Raise the box (approximately 3/4 inch) and remove the hitch assembly. Use the 1/8 thick spacer plate to fill the space where the hitch assembly was located. Apply loctite (No. 2242) to the box mounting bolts and reinstall securely.
- STEP 12, Set your new Brute II hitch on a floor jack. Roll it under your vehicle and jack it up into place. With the jack still in place, align the applicable holes and bolt it to the vehicle frame with the hardware supplied in the mounting bolt package (item 29).
- STEP 13, Tighten securely all mounting and bumper face hardware and check all previously installed hardware.
- STEP 14, Install the license plate light (item 13) in the bumper face. This should be located on the side opposite from the pull handle.
- STEP 15, On chrome bumpers only – Attach the adhesive backed skid pads (item 27) to the bumper. Locate to suit your application.
- STEP 16, Stand back and enjoy the look of your new Brute II hitch from Ag Systems Inc.

# WARRANTY CLAIM FORM

<b>Dist. Acct. No.</b>	<b>Shop Order No.</b>	<b>Part Number</b>	<b>Description</b>	<b>Qty</b>	<b>Distributor Total</b>	<b>Approved Total</b>
<b>Customer Name</b>						
<b>City</b>	<b>State</b>					
<b>Country</b>	<b>Postal Code</b>					
<b>Model No.</b>	<b>P.I.N.</b>					
<b>Warranty Start Date</b>	<b>Failure Date</b>	<b>Date of Repair</b>				
<b>Describe Problem(s)</b>						
<b>Outside Expenses</b>			<b>Invoice No</b>			
<b>Itemize Labor</b>						
<b>Total Parts Cost Including Outside Expenses:</b>						
<b>Labor</b>	<b>HRS</b>	<b>X</b>	<b>Hourly Rate</b>			
<b>Warranty Claim Total:</b>						
<b>Distributor Signature</b>						
<b>Authorized Signature</b>						<b>Status</b>
<b>Date</b>						