

Heartland
AG SYSTEMS
EQUIPMENT

PRESENTS

MT600TA /
MT900TA
SERIES
TENDERS

OPERATOR'S MANUAL
AND PARTS LIST

WARRANTY REGISTRATION

TO THE DEALER:

Inspect the implement thoroughly after assembly to be certain it is functioning properly before delivering it to the customer. Check off each item as it is found satisfactory or after proper adjust is made.

PRE -DELIVERY CHECKLIST

- _____ 1. All hardware properly tightened.
- _____ 2. Lubrication of grease fittings.
- _____ 3. All decals properly located and readable.
- _____ 4. Other adjustments, "level operation", "drawbar height", etc.
- _____ 5. Proper tongue weight after all options are mounted.
Adjustments made if required.
- _____ 6. Overall condition. Touch-up paint any scratches. Clean and polish
- _____ 7. Operator's manual.

Review the operator's manual with the customer. Explain the following:

- _____ 1. Safe operation and service
- _____ 2. Correct machine installation and operation.
- _____ 3. Correct and periodic lubrication and maintenance.
- _____ 4. Daily and periodic inspection.
- _____ 5. Troubleshooting.
- _____ 6. Storing machine.
- _____ 7. Heartland AG Systems parts and service
- _____ 8. Have the customer write the machine model and serial number in the space provided in the manual introduction
- _____ 9. Give the customer the operator's manual and encourage the customer to read the manual carefully.

Seller Information	
Date set-up	_____
Signature	_____
Dealer name	_____
Address	_____
City, state, zip	_____
Phone	_____

Customer Information	
Date delivered	_____
Customer name	_____
Customer address	_____
Signature	_____
Model number	_____
Serial number	_____

MT600 / MT900 SERIES TENDER CONTENTS

	PGS.	PGS.
TO THE OWNER	2	61-62
WARRANTY	W1-8	63-64
SAFETY INSTRUCTIONS	6-19	65-68
OPERATING INSTRUCTIONS	20-25	69-76 KUBOTA 69-76 CAT
MAINTENANCE AND SERVICE	26-29	75-76 DEUTZ
PARTS	30-104	77-78
-DISCHARGE DIMENSIONS	31-34	79-80
-MOUNTING EQUATIONS	35-38	81-84
-MT900TA TRAILER MOUNT	39-40	85-88
-MT900TA TRUCK MOUNT FRAME	41-42	89
-MT900TA SCALE PACKAGE	43-44	90
-MT900 LOWER AUGER	45-46	91-92
-MT600TA MAIN	47-48	93-94
-MT600TA SCALE PACKAGE	49-50	95-96
-MT600 LOWER AUGER	51-52	97-98
-TRANSITION BOOT	53-54	99-100
-VERTICAL AUGER W/ TRANSITION BOOT	55-56	101-106
-UNLOAD AUGER	57-58	107-112
-SLIDING DOOR ASSEMBLY	59-60	113-116
-TRAILER MOUNT LADDERS		61-62
-TRUCK MOUNT LADDERS		63-64
-MOUNTING OPTIONS		65-68
-KUBOTA ENGINE SKID/ENCLOSURE		69-76 KUBOTA
-CAT ENGINE SKID		69-76 CAT
-DEUTZ ENGINE SKID		75-76 DEUTZ
-TRUCK MOUNTED OIL TANK		77-78
-GREASE BANK SET UP		79-80
-MT900 DECALS		81-84
-MT600 DECALS		85-88
-TRUCK WIRING DIAGRAM		89
-UNLOAD AUGER WIRING DIAGRAM		90
-MT600 TRUCK HYDRAULICS		91-92
-MT900 TRUCK HYDRAULICS		93-94
-MT900 TRAILER HYDRAULICS		95-96
-MT900 WET KIT HYDRAULICS		97-98
-TARP END CAP/BOW DIVIDERS		99-100
-MT900 ROLL TARP		101-106
-MT600 ROLL TARP		107-112
-VIBRATOR PACKAGE		113-116

TO THE OWNER

Congratulations on your selection of the Heartland AG Systems Tender.

The Heartland AG Systems Tender has been designed to provide years of profitable and dependable service. To assure maximum performance of your Tender it is mandatory that you thoroughly study the operator's manual and follow its recommendations. Proper operation and maintenance are essential for safety and to maximize machine life.

It is the owner, manager, and/or operators' responsibility to:

Operate and maintain this tender in a safe manner and in accordance with all applicable local, state, and federal codes and or laws; and in compliance with labeling instructions by the supplier of the chemicals being used.

Make sure each and every operator has read this manual and thoroughly understands safe and correct operating procedure.

Make sure unauthorized people neither operate the Tender nor are in the vicinity of the Tender while it is in operation.

Make sure the Tender is maintained to preserve and/or improve safety, accuracy, and reliability of the system. Read and follow the maintenance schedule in this manual. Furthermore, as additional technology becomes available, the owner is responsible for improving the safety, accuracy, and reliability of the Tender.

Fulfill all warranty obligations so as not to void the warranties. The warranty information on the following pages outlines the warranty policy of Heartland AG Systems and its suppliers.

Heartland Ag Systems, dba Heartland Agriculture, LLC reserves the right to make product improvements to the equipment at any time. Heartland AG Systems shall not be obligated to make such changes to the machines already in service.



Warranty Policies and Terms

The Heartland Agriculture, LLC warranty is a limited warranty that is provided to the retail purchaser in return for consideration paid as part of the purchase price for a product. The selling dealer must review the warranty coverage with the retail purchaser and obtain a signature on the Operators Manual for warranty verification.

The warranty described here is for Heartland Agriculture, LLC doing business as Heartland AG Systems and its product line Heartland AG Systems Equipment sold and registered in the United States and Canada and normally operated in the United States and Canada.

Warranty Period

The warranty period for all coverage begins at the time that any person, dealer or agent first places the unit into service. At the latest, a unit is placed into service when purchased or delivered to a purchaser.

What's Covered

If a defect in material or workmanship is found in a unit and reported during the Warranty period, Heartland AG Systems will pay parts and labor costs to repair the defects if the services are performed by an authorized Heartland AG Systems dealer. If parts are needed during the repair, Heartland AG Systems will, at its option, use genuine Heartland AG Systems, or remanufactured parts.

Heartland AG Systems provides no warranty, express or implied, for a component or other item that is separately warranted to the purchaser by its manufacturer, such as tires. Check with your local dealer for these details.

Exclusive Remedy

The remedy of repairing a defect in material or workmanship at a Heartland AG Systems dealership under the terms of this warranty is the purchaser's exclusive remedy and is in lieu of any other remedy otherwise available.

No Modification or Extension of Warranty

The Heartland AG Systems Warranty is limited to the written terms in the warranty statement. Heartland AG Systems does not authorize any person, dealer, or agent to change or extend the terms of this warranty in any manner. Any assistance to the purchaser in the repair or operation of any Heartland AG Systems product outside the terms or limitations or exclusions of this warranty will not constitute a waiver of the terms, limitations or exclusions of this warranty, nor will such assistance extend or re-establish the warranty.

The warranty is void if the unit is used in an application for which it is not designed or the unit has been scrapped, salvaged, stolen, junked or totaled.

Limitations and Exclusions

The Heartland AG Systems warranty gives you specific legal rights and you may also have other rights, which vary from state to state. This section contains the entire Heartland AG Systems warranty. Heartland AG Systems makes no other representations or warranties, expressed or implied, and specifically excludes the implied warranties of merchantability and fitness for particular purpose. Heartland AG Systems will not be liable for incidental or consequential damages resulting from a breach of the written warranty or any implied warranty.

- These limitations and exclusions may not be allowed by some states or provinces and shall not apply to the extent such limitations or exclusions are not allowed by applicable state/provincial law.

Owner's Responsibility

The Heartland AG Systems Warranty remains in effect during the warranty period if the owner performs the required maintenance at the recommended intervals outlined in the product's operator's manual and the unit is operated within its rated capacity. Genuine Heartland AG Systems service parts or Heartland AG Systems approved service parts that meet Heartland AG Systems specifications must be used for maintenance and repairs.

What Is Not Covered

- Replacement of non-defective wear items expected to be replaced during the warranty period, including, but not limited to: lights, fuses, belts, drive sprockets and chains, hose, soil engaging tools, spray tips, fertilizer deflectors, spinner blades and accessories or items replaced due to customer demand.
- Normal maintenance parts and service, including, but not limited to lubrication, coolants, and filters.
- All travel costs associated with hauling or towing a customer's machine to and from a repair center related to any warranty repair unless specifically covered by a program or policy.
- Repairs arising from any unauthorized modification to the product.
- Repairs arising from service performed by agents not approved by Heartland AG Systems.
- Repairs arising from storage deterioration, failure to maintain the equipment, improper use of the equipment, collision or other accident, vandalism, or other casualty, or operation beyond the rated capacity or specifications.
- Repairs arising from abuse or neglect including, but not limited to operation without adequate lubricants or coolant, over-speeding, contaminated fluids, improper storage, starting, warm-up, or shutdown practices.
- Failure of the machine, its implements or attachments caused by improper field application or overloading.
- Premiums charged for over-time labor costs.
- Economic loss, including lost profits, crop loss, equipment rental or other expenses.
- Cost associated with cleaning of machine in preparation for service.
- Loss or damage during shipment.

- Cost of initial setup or installation of any optional equipment or attachments to a unit.
- Items used for repairs include, but are not limited to: solvents, cleaners, anti-seize lubricants, oil-dry, shop towels, shop supplies, special tools, etc.
- Included, but not limited to are checkups, adjustments, and shimming, tune-ups, spread pattern checks, etc.
- Unauthorized modification or field fixes.
- All costs of special tools or shop supplies incurred with repairs.
- Claims for stolen equipment or parts.
- Claims for replacing a complete assembly when the repair is less than the replacement.
- Claims involving the inspection or reconditioning of units.
- Shop comebacks: any duplicate, repeat, or comeback repair resulting from improper diagnosis, testing, or poor service work.
- Cost of removing or installing Non-Heartland AG Systems optional equipment or attachments.

Base Warranty Coverage

- Base Warranty is the factory warranty provided to the customer at no additional cost for a specific period covering the complete machine.

• Liquid Applicators, except tires	1 Year
• Spreaders and Tenders, except tires	1 Year
• Nh3 Wagons, except tires	1 Year
• Bumper Hitches	1 Year
• Disc Covers	1 Year
• Parts	90 Days
• Tandem Wagons (except tires and main frame)	1 year
o Tandem Wagon main frame	5 Years
• Nitromaster Toolbars shall carry the following pro-rated warranty:	
o Year one, all components except tires	100%
o Year two, center section and wings	80%
o Year three, center section and wings	50%
o Year four, center section and wings	25%
o Year five, center section and wings	10%

Tires

Tires installed on all Heartland AG Systems Equipment are warranted and serviced by their manufacturer's service outlets. Some manufacturers have separate service outlets for off road agricultural and construction equipment. Service is available by contacting the tire manufacturer's local representative.

Warranty Registration

All machinery items, which are invoiced by Heartland AG Systems on separate receivables, must be registered for warranty. The warranty period for all coverage begins at the time that any person, dealer, or agent first places the unit into service. New machine warranty coverage begins when the machine is registered. Registration is accomplished when a properly completed Warranty Registration is received and processed by Heartland AG Systems.

Operator's Manual/Warranty Receipt Verification

The Heartland AG Systems New Equipment Limited Warranty for Agricultural Equipment statement must be filled out and signed by the customer indicating receipt and an understanding of the operator's manual and the warranty statement,

- The original form must be mailed to the address on the form.
- Make one copy for the Dealer. This copy must be retained by your dealership the same as any other legal document.
- Make a second copy for the customer.

Heartland AG Systems Responsibility

If a defect in material or workmanship is found in a product during its warranty period, Heartland AG Systems will pay parts and labor costs to repair the defect when the service is performed by an authorized Heartland AG Systems dealer or agent. If parts are needed during the repair, Heartland AG Systems will, at its option, use genuine Heartland AG Systems new or remanufactured parts. These responsibilities include, but are not limited to:

- Costs for repairs that are the result of defects in material and workmanship
- Payment to dealers per policy in a timely manner
- Service information to dealers
- Identify product deficiencies and take corrective action by field campaigns
- Make determination of premature wear
- Provide unit that is free of defects in material & workmanship

Dealer Responsibility

Heartland AG Systems dealers are responsible for providing prompt, courteous, and willing service to all Heartland AG Systems equipment owners. These responsibilities include but are not limited to:

- Equipment set-up and pre-delivery
- Sell the right product for the intended application
- Inspect the unit and initiate recovery action on any shipping damage and or shortages
- Instruct customer on proper use, maintenance, and safety features of machine
- Advise and explain warranty coverage to customer
- Diagnose the problem, repair the unit, and submit claims in accordance with the terms and conditions of the warranty claim policies
- Take responsibility for saying "NO" to customers on non-warranty failures
- Apply failure analysis to questionable repairs
- Complete product update campaigns
- Have properly trained technicians and adequate tools for the job
- Retain proper documentation of failure repaired

Owners Responsibility

The Heartland AG Systems warranty remains in effect during the stated warranty period if the owner performs the required maintenance at the recommended times as outlined in the products operator's manual. Genuine Heartland AG Systems or Heartland AG Systems approved service parts must be used for maintenance. Additionally, the owner will pay for all transportation or travel expenses related to any warranty repair.

These responsibilities include, but are not limited to:

- Perform maintenance as indicated in the operator's manual
- Use the unit in the correct application (non-abusive)
- Notify dealer of failures and have the machine available for repair in a timely manner
- Training operators
- Travel cost, towing charges, and service calls
- Normal wear items
- Machine damage (accidental)
- Adjustments for application
- Machine inspection (daily walk-around)

Warranty Eligibility

The dealer is responsible to determine that any Heartland AG Systems equipment is covered by Heartland AG Systems warranty before performing a repair and that the repair is a warrantable failure. Any dealer who is in doubt of the equipment's warranty eligibility may call Heartland AG Systems for verification.

Warranty Repairs Made by the Customer

If a Heartland AG Systems dealer determines that the customer is capable, and the customer requests permission to perform select(warranty)repairs on his product, the Heartland AG Systems dealer is authorized to grant this customer request. The servicing dealer should provide the parts to the customer upon request, and to assure that customer is properly instructed on how to perform the repairs correctly.

The servicing dealer is responsible and accountable for claim accuracy and validity; specifically, in areas such as the parts replaced date, and assurances that the parts are installed as instructed by Heartland AG Systems. The comments section of the claim should clearly state that the customer installed the parts. The claim reimbursement will be for parts and applicable handling only. No labor is allowed! All replacement parts must be held for possible recall.

Parts Shortages on Whole-Goods

Dealers may submit a claim for parts shortages discovered during pre-delivery or during final assembly at the dealer's location. All claims for shortages must be submitted 5 days from the original ship date from the plant and before the warranty start date.

Warranty Reimbursement Policies

Heartland AG Systems provides for warranty reimbursement due to defects in material or workmanship only. Warranty does not include restoring any machine or portion thereof, which has accumulated hours of operation, to factory new condition. This includes customer owned and used equipment.

Except for only a few items not available through Heartland AG Systems, all Heartland AG Systems manufactured equipment warranty repairs must be performed using only Heartland AG Systems genuine new or remanufactured parts and accessories. Installation of non-Heartland AG Systems parts does not qualify for warranty reimbursement and can void the machine's warranty.

Parts

It is fully expected that all claims be filed using part numbers from the applicable Heartland AG Systems equipment parts book whenever such part number exists. Heartland AG Systems shall reimburse the dealer at the dealer net price (cost) in effect on the parts replaced date.

Labor

Heartland AG Systems shall reimburse the dealer at 80% of the dealer's posted retail shop labor rate. The retail shop labor rate shall be subject to verification by Heartland AG Systems from copies of actual dealer invoices to customers.

Outside Charges

Specialized repair such as that done by a machine shop will be accepted as part of a warranty claim at actual cost. Explain the parts used and the service work performed in the description section of the claim and retain a copy of the receipt. Retain a copy of the invoice with the shop work order to support the claim. Outside repairs that exceed the cost of the same repair, if performed by the dealer, will be reimbursed at a lower rate.

Freight



Heartland AG Systems will pay the freight charges when a warranty recalled part is to be returned to Heartland AG Systems.

Travel

Travel will only be reimbursed when authorized by a field campaign.

Repairing or Replacing Parts and Components

When performing a warranty repair, a complete part or component should not be replaced under warranty if the repair can be accomplished at a lower cost. If the total cost of the repair including the cost of parts, labor, and/or outside labor or materials is less than 75% of the cost of the parts, the part must be repaired.

Filters and Lubricants

Replacement of lubricants and filters do not qualify for warranty reimbursement unless damage caused by a defect in material or workmanship results in contamination or sudden loss of fluid. Lack of maintenance, operator misuse, or neglect will not qualify for warranty reimbursement.

Claim Form Guidelines

Claims Must Have

1. Product identification number (PIN) or serial number. All characters of the PIN must be used on the warranty claim.
 - Claims for parts warranty must use the word "PARTS" for the PIN. An invoice that shows date of sale or date of installation must be supplied for all parts claims.
2. Model Number
3. Date of failure – Claims must be submitted within 30 days or repair.
4. Date of repair
5. Warranty start date. Date the unit warranty starts or date the parts were sold for parts warranty.
6. Description of the problem. Describe all problems pertinent to the claim.

Comments should be as precise as possible, attach a separate sheet if necessary, to describe the problem.
7. Description of the work performed. List each significant action of the repair.
8. Itemize labor. Provide a breakdown of labor for each significant repair action in the "Describe Work Performed" column.
9. Shop order numbers. The shop order number field is used for recording your shop work order number that is related to the claim. The shop order number field can also be used to record the parts invoice number when claiming a parts warranty.
10. Customer information. Customer information includes the customer name, city, state, county, and postal code. It must match the warranty registration.
11. Warranty claim total. The total of all reimbursement costs requested.
12. Dealer signature and date. All claims must be signed and dated by the distributor to be validated.

SAFETY

INSTRUCTIONS



THIS MESSAGE ALERT SYMBOL INDICATES IMPORTANT SAFETY MESSAGES IN THIS MANUAL. WHEN YOU SEE THIS SYMBOL, CAREFULLY READ THE MESSAGE THAT FOLLOWS AND BE ALERT TO THE POSSIBILITY OF PERSONAL INJURY OR DEATH.

Safety Decals on this machine use the words **Danger, Warning or Caution**, which are defined as follows:

- **DANGER:** Indicates an immediate hazardous situation which, if not avoided, will result in death or serious injury. The color associated with Danger is **RED**.
- **WARNING:** Indicates a potentially hazardous situation on which, if not avoided, will result in serious injury the color associated with Warning is **ORANGE**.
- **CAUTION:** Indicates a potentially hazardous situation which, if not avoided, may result in minor or moderate injury. It may also be used to alert against unsafe practices. The color associated with Caution is **YELLOW**.



WARNING

IMPROPER OPERATION OF THIS MACHINE CAN CAUSE INJURY OR DEATH. BEFORE USING THIS MACHINE, MAKE CERTAIN THAT EVERY OPERATOR:

- Is instructed in safe and proper use of the machine.
- Reads and understands the Manual(s) pertaining to the machine.
- Reads and understands ALL Safety Decals on the Machine.
- Clears the area of other persons.
- Learns and practices safe use of machine controls in a safe, clear area before operating this machine on a job site.

It is your responsibility to observe pertinent laws and regulations and follow Heartland AG Systems instructions on machine operations and maintenance.

Safety Instructions

The following chapter covers recommended safety instructions, along with other general recommendations and specific machine safety precautions that should be read thoroughly before operating the machine.

Safety

Read and comply with the operators manual and safety instructions before operating the machine.

Understand that your safety and the safety of other persons is measured by how you service and operate this machine. Know the positions and operations of all controls before you try to operate. **Make sure you check all controls in a safe area before starting your work.**

Read this manual completely and all other manuals provided with this vehicle, plus make sure you understand the speed, brakes, steering, stability, and load characteristics of this machine before you start to operate.

The safety information given in this manual does not replace safety codes, insurance needs, federal, state, and local laws. Make sure your machine has the correct equipment required by local laws and regulations.



Heartland AG Systems is continuing to work for your safety by making tenders with better protection and by giving these rules for safe operation.

 **WARNING: THIS SAFETY ALERT SYMBOL INDICATES IMPORTANT SAFETY MESSAGES IN THIS MANUAL. WHEN YOU SEE THIS SYMBOL, CAREFULLY READ THE MESSAGE THAT FOLLOWS AND BE ALERT TO THE POSSIBILITY OF PERSONAL INJURY OR DEATH.**

Personal Safety

Throughout this manual and on the machine's safety decals, you will find precautionary statements: **DANGER, WARNING, or CAUTION** followed by specific instructions or ISO two panel safety pictorial symbols. These precautions are intended for your personal safety.

Failure to follow **DANGER**, **WARNING**, or **CAUTION** instructions may result in serious bodily injury or death.

- **DANGER:** Indicates an immediate hazardous situation that, if not avoided, will result in death or serious injury. The color associated with Danger is **RED**
- **WARNING:** Indicates a potentially hazardous situation on which, if not avoided, will result in serious injury the color associated with Warning is **ORANGE**.
- **CAUTION:** Indicates a potentially hazardous situation which, if not avoided, may result in minor or moderate injury. It may also be used to alert against unsafe practices. The color associated with Caution is **YELLOW**.
- ISO two panel **pictorial symbol decals** are defined as follows:
 - The first panel indicates the nature of the hazard.
 - The second panel indicates the appropriate avoidance of the hazard.
 - Background color is **YELLOW**.
 - Prohibition symbols such as   and  if used, are **RED**.

Safety Rules

- DO NOT operate or service this machine unless you have read and understood the Operators Manual and have been properly trained in the machine's operation.
- Before starting the engine, be sure all operating controls are in neutral or park position. This will eliminate the accidental movement of the machine or startup of power driven equipment.
- This machine requires an operator at all times. NEVER leave the machine running and unattended.
- ALWAYS be sure the work area is clear of persons before operating the machine. NEVER allow anyone in the work area during machine operation. DO NOT allow inexperienced persons to operate this machine.
- Sound horn of tow vehicle before operating the machine.
- **NO RIDERS** – A frequent cause of personal injury or death is persons falling off and being run over. DO NOT permit others to ride.
- For road travel, use flashing warning lamps unless prohibited by law and keep SMV (Slow moving vehicle) visible.

- ALWAYS put the controls in neutral, shut the engine off, apply the parking brake, and remove the key BEFORE exiting the tow vehicle.
- Extra weight and bad traction conditions, such as mud or ice, increase your stopping distance. Remember, a loaded machine increases the distance needed to stop.
- DO NOT smoke while servicing the machine.
- DO NOT operate the machine while under the influence of alcohol or drugs.
- Hydraulic oil or Diesel fuel are high pressured systems. Make sure all lines and fittings are tight and in good condition. These fluids, escaping under pressure, can have sufficient force to penetrate skin and cause serious injury. Failure can result in serious injury or death.
- Escaping hydraulic fluid under pressure can have sufficient force to penetrate skin, causing serious injury. NEVER check for leaks by using any part of your body to feel for escaping fluid.
- Before servicing the machine, make sure the machine has cooled down. Hydraulic components can get hot enough to cause serious injury.
- After servicing the machine, ALWAYS replace guards and shields. NEVER operate your machine with guards and shields removed.
- Be aware of all pinch point on machine and keep clear.
- Keep bolts tight at all times. Always replace worn or broken parts immediately after they are discovered. DO NOT use the vehicle if any parts are not functioning properly.
- Do not replace parts with other than genuine factory parts. Doing so could decrease the effectiveness of safety features or the accuracy of the machine.
- This machine is designed for the farming industry. Comply with your local and state laws governing weight, lighting, licensing, overhang, bumpers, maximum width, transportation of chemicals, and any other regulations that might apply.

Safety

- When disconnecting the battery terminals, remove the Negative (-) cable first, then remove the Positive (+). When connecting cables, connect the Positive (+) first, then connect the Negative (-).
- Disconnect the battery (both terminals) before welding on any parts of the machine. Failure to do so may cause damage to sensitive electrical components.
- **BATTERY ACID CAUSE SEVERE BURNS.** Batteries contain sulfuric acid. **AVOID** contact with skin, eyes or clothing. Antidote:
 - EXTERNAL – flush with water.
 - INTERNAL – drink large quantities of water or milk. Follow with milk of magnesia, beaten egg, or vegetable oil. Call physician immediately. **EYES** – flush with water for 15 minutes and get prompt medical attention.
- **BATTERIES PRODUCE EXPLOSIVE GASES.** Keep sparks, flames, and cigarettes away. Ventilate when charging or using in enclosed space. Always shield eyes when working near batteries. **KEEP OUT OF REACH OF CHILDREN.**
- When working around stage batteries, remember that all exposed metal parts are “live”. **NEVER** lay a metal object across the terminals because a spark, short circuit, explosion, or personal injury may result.

Electrical Line Safety

- Know the area before operating the machine. Be aware of power lines, electrical boxes, debris, and rocks.
- Watch for adequate overhead clearance when operating the machine.

Machine Operation and Roll-Over Safety

- **DO NOT** ride or allow other persons to ride on the machine. Riders can fall or can cause an accident
- **DO NOT** operate the machine while under the influence of alcohol or drugs.
- Be alert and always know the location of all workers in your area. Keep all other persons completely away from your machine. Injury or death can result if you do not follow these instructions.

Noise Level Safety

- Exposure to high noise levels may cause hearing loss. Wearing suitable hearing protective devices protects against loud noise.

Hazardous Chemicals

- If you are exposed to, or come in contact with, hazardous chemicals you can be seriously injured. The fluids, lubricants, paints, adhesives, coolants, etc., used with your machine can be hazardous.
- Material Safety Data Sheets (MSDS) provide information about the chemical substances within a product, safe handling procedures, first aid measures and procedures to be taken when the product is accidentally spilled or released. MSDS are available from your chemical dealer. It is the operator's responsibility to be familiar with the safe handling of the chemical used.
- Before you service your machine, check the MSDS for each fluid, lubricant, etc., used in this machine. This information indicates what the risks are and how to service the machine safely. Follow this information when servicing the machine.
- Before you service this machine and before you dispose of the old fluids and lubricants, always remember the environment. DO NOT put oil or fluids into the ground or into containers that can leak
- Check with your local environmental or recycling center, or your dealer for correct disposal information.
- Personal Protective Equipment (PPE) is protective gear worn by pesticide handlers as specified in the use directions on a pesticide label.

Maintenance Safety

- Before you service the machine, place a Do Not Operate tag on the machine.
- Always keep safety and information decals clean and visible. Replace decals that are damaged, lost, painted over, or cannot be read.
- When assembling, operating, or servicing the machine, wear protective clothing and personal safety devices that are necessary for the particular procedure. Some personal safety devices that may be necessary are protective shoes, face and/or eye protection, hard hat, heavy gloves, filter mask and hearing protection.

- DO NOT wear jewelry or loose fitting clothing, which may get caught in moving parts. Always wear close fitting clothing. Keep hands, feet, clothing, and hair away from moving parts.
- NEVER attempt to clear obstruction or objects from the machine while the engine is running.
- ALWAYS stop the engine and remove the key from the key switch when leaving the operators seat or the machine.
- When servicing the machine, always have the machine on a firm level surface. If shields or guards are removed or opened for service, always replace them before operating the machine. Never operate the machine with missing or open shields or guards.
- Keep the area used for servicing the machine clean and dry. Wet or oily floors are slippery. Wet spots can be dangerous when working with electrical equipment. Be sure all electrical outlets and tools are properly grounded.

Tire Inflation

- Consult your vehicles operator's manual for proper tire inflation.

First Aid Kit

It is recommended that you have a First Aid Kit on the job site and in your maintenance area.

Read Operators Manual

Decals which display the "Read Operators Manual" symbol are intended to direct the operator to the Operators Manual for further information regarding safety, maintenance, adjustments and/or procedures for specific areas of the machine.

When a decal displays symbol shown, refer to the appropriate page of the Operators Manual. Refer to the Detail Index at the end of this manual for locating specific items about your machine.

Fire Extinguisher

It is recommended that you have a fire extinguisher on your machine. A fire extinguisher is available from your dealer and can be installed on your machine.

This dry chemical fire extinguisher is approved for Class A, B, and C type fires. The operating temperature is -54° to 49°C (-65° to 120°C)

Hand Signals

It is recommended that all persons on the job site use hand signals for communication. Before you start, make sure all persons understand the signals that will be used.

Start Engine



Stop Engine



Come To Me

Move hands forward and rearward - palms in



Move Away from Me

Move hands forward and rearward - palms out



Go This Far



All Stop and Hold



Stop

Move one hand back and forth



Emergency Stop

Move both hands rapidly back and forth



Turn Machine Left

To stop movement, stop moving hand and make a fist

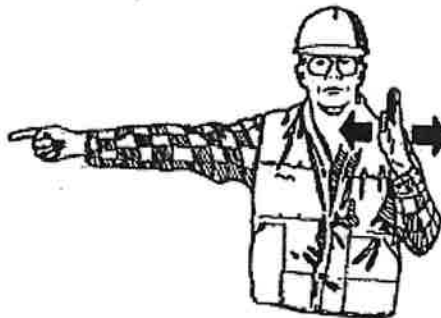

Turn Machine Right

To stop movement, stop moving hand and make a fist



Safety Decals

Check and replace any worn, torn, hard to read, or missing safety decals on your machine.



Your MT600 / MT900 tender is designed to be mounted on a chassis for over the road transportation of granular fertilizer and chemicals. Comply with all local, state, and federal codes, laws, and/or regulations including, but not limited to:



-vehicle weight, height restrictions, bumper, brake, and light requirements.



Warning: Always wear proper personal protective equipment (PPE) when handling herbicides and other chemicals.



Caution: Fertilizer is very corrosive. Over time it will oxidize steel. This weakens steel parts and can cause possible safety hazards. Periodically check safety shields and structural members for corrosion. Replace or repair anything that could cause a potential safety hazard.

NOTES:

OPERATING **INSTRUCTIONS**

Operating Instructions

This chapter starts with a pre-operation checklist. Then it explains certain parts of the machine and how they operate. It also presents detailed instructions for the first time operators.

Pre-Operation Checklist



CAUTION: Read the Safety and Operating Instructions section of this manual before operating the MT600/MT900 Series Tender.

Inspect unit

- Be sure all shipping fasteners are removed
- Check tender thoroughly for screws, bolts, fittings, etc., which may have come loose during shipping.

Transporting

Before transporting the unit, make sure it is secured to the truck bed, trailer, etc. Be sure that the tarp and auger are properly secured in place. Make sure the auger is in the "Home" position before transporting. (*Home position – means that the auger is resting in its cradle*)

Operating the Tender

Hydraulic Drive-

The Hydraulic driven tender can be powered by any hydraulic power source, which can supply two sources of 25 GPM max. @ 3000 psi. When first installing, be sure the auger turns the proper direction, if backwards reverse the hoses.

- Truck Hydraulic
 - PTO Ratio needed 130-135%
 - PTO driven twin gear pump SAE B-4 Mount 1"-15T shaft (*Note: Pump will need extra support*)
- Engine Hydraulic

- Follow the manufacturer's recommendations in the maintenance manual.
- Maximum engine RPM will produce GPM needed
- Check to see the engine has proper oil level before starting
- Make sure oil tank valves are open

Unit-

Gates-

- CAUTION: Never load unit with gates open
- ALWAYS have the auger running before opening the hopper gate
- ALWAYS shut the gate and empty the auger before shutting the auger off.
- For some materials the gates are capable of allowing more opening than the auger may extract. Some materials may require feathering of the gate opening or slugging of the auger may occur. Operators must be aware and adjust gate accordingly.

Dump Doors-

- Pit dump doors
 - Are located under each compartment
 - Enables pit unloading without operating any of the augers
- Rear dump door
 - Standard on the MT900TA units
 - Standard on the MT600TA units
 - Located at the rear of the lower auger
 - Requires ONLY the lower auger to be turning
 - Certain types of materials may require feathering of the gates, to control the flow of product, and prevent slugging the auger.
 - To prevent slugging of the auger, the clean out door on the vertical auger may also be opened.
 - When hoppers are empty, also run Vertical Auger to empty all augers.

Transport-

- ALWAYS make sure the auger is in the "Home" position before transporting the tender.

Auger

- ALWAYS use CAUTION when lifting and rotating the augers, to make sure there are no obstructions in the way

- **ALWAYS** use CAUTION when approaching the built in rotational safety stops, to prevent damage to the machine.
- When raising and lowering the auger feather the hydraulic cylinder at the end of the stroke to prevent damage to auger, screw, or cradle.
- Lift the auger out of “Home” position
 - *(Home position mean that the auger is resting in the cradle.)*
- Rotate the auger to the correct position for unloading.
- Adjust the height of the auger for unloading
- Start the augers
 - Use Engine Throttle Control to set engine to run the Auger at the desired RPM
 - DO NOT run lower auger without discharge auger running, except for rear dumping
- Start the flow of material
 - Open the gate of the compartment to be unloaded halfway.
 - Adjust auger speed if necessary
 - Feather the gate open all the way
- Stopping Discharge
 - *(After unloading the desired amount of material, or the compartment is empty.)*
 - Close compartment gate
 - Turn off flow control valve
 - Return auger to “Home” position

NOTES:

MAINTENANCE

AND SERVICE

Maintenance and Servicing

Daily Machine Maintenance

Overnight Storage

AVOID overnight storage of material in machine if possible.

Build-up of Material

Hosing the machine out with water after each day's use will eliminate build-up, if this is done before the material has hardened. The unit should be washed regularly. (Note: Use 2" flush access located on the front end of lower unload auger.)



CAUTION: All residue that is washed off the tender must be disposed of in accordance with local, state, and federal EPA regulations.

Tarp

Loosen the tarp or open Roll tarp, so any excess moisture can escape.

Check to ensure ratchet strap running between the endcaps is tight.

Fluids

Check diesel & engine oil levels

Weekly Machine Maintenance

Greasing

Grease all bear fittings 1 shot every 75 hours, grease all supports 2 pumps every 75 hours, (see *Grease Bank Setup Sheet*). Use only a standard grease gun, **DO NOT USE AN AIR GUN.**



IMPORTANT: DO NOT over-grease. Over-greasing will break the seals on the bearings and allow fertilizer and dirt into the bearing; thereby, causing bearing failure.

Physical-

- Check tire pressure
- Check lug nuts

- Check tender mounting bolts
- Check lights, brake hoses, and fittings
- Check brake lining and adjustment
- Visual inspection for any missing/loose hardware, oil leaks, worn items, or damage

Between Season Maintenance

Hopper Body

Clean all the old fertilizer out of the unit and wash it down thoroughly. Clean, lubricate, and inspect guides for hopper gates.

Auger

Use washout port connection to wash out.



CAUTION: All residue that is washed off the tender must be disposed of in accordance with local, state, and federal EPA regulations.

Unit

- Remove the tarp or open and secure Roll tarp to prevent moisture from being trapped inside the hopper.
- If equipped with engine, remove the battery and store inside.
- If stored outside, cover the engine with a cover or tarp of some kind.

Wood Bearing / Hanger Bearing

Visually check part number RHB203631 Wood Bearing for wear before/after each season. This is a wear item that will need to be replaced periodically. See page 46A for detailed drawing. The Wood Bearing can be inspected by removing the plate cover (item 15). For Hanger Bearing replacement instructions, see pages 29-1 thru 29-3

Oil Filter and Oil

Change filter once a year

Change oil as required per oil manufacturer.

Physical

- Check axles/suspension components per decal on side of trailer
- Bleed brake air tank to prevent rust
- Check/Clean interior tank strainer on bottom of oil reservoir

Fluid Levels and Instructions

- Premix Anti-Freeze (*see engine owner's manual*)
- Motor Oil (*see engine owner's manual*)
- Hydraulic Oil (P/N: 4050) – 56 gallons
- Gear Lube EP85-140 (P/N: 1050) – 20 oz.

****IMPORTANT****

- Check all fluid levels BEFORE and AFTER each season
- Follow manufacturer maintenance schedule for engine if equipped.
- For Gear Box P/N: 1087194 (*item 10 on pages 53-54*), oil can be checked and filled using the gear lube plug located on the side of the gear box. If low, change or refill using EP85-140

This page intentionally left blank

Hanger Bearing Replacement

Tools Required:

Cordless Impact Driver or Drill

10" Socket Extension

9/16" Wrench

Punch

Anti-Seize

9/16" Socket

Flex Socket Adapter or Universal Socket Joint

Vise Grip or Pipe Wrench

Hammer

Wood 2" x 4" or equivalent approximately 4' Long

Note: Ensure power unit is shut down with key removed if applicable before starting maintenance.

Procedure:

1. Using a 9/16" wrench and socket remove two bolts, nuts, and washers securing the cover plate as shown in Figure 1 below and remove the cover plate.

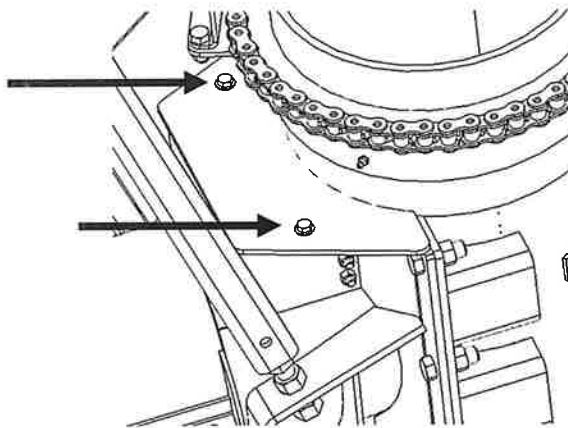

Figure 1

2. Using a 9/16" wrench and a 9/16" socket with 10" socket extension remove the bolts and nuts holding the top strap over the hanger bearing as shown in Figure 2 below. Remove the top strap and top half of the hanger bearing.

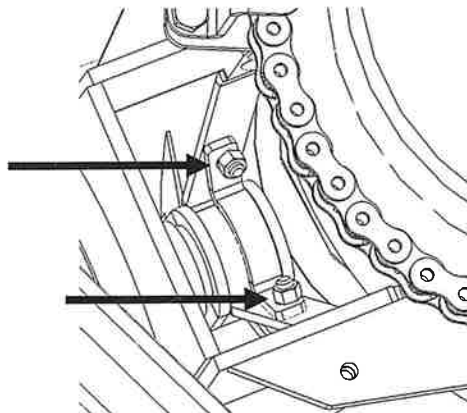

Figure 2

3. Open the bottom access/pit dump door as shown in Figure 3 Below and use a 2" x 4" to prop up the lower auger to relieve weight off of the hangar bearing. Wedge the 2" x 4" against the center pipe of the auger and the ground until the auger is lifted slightly.

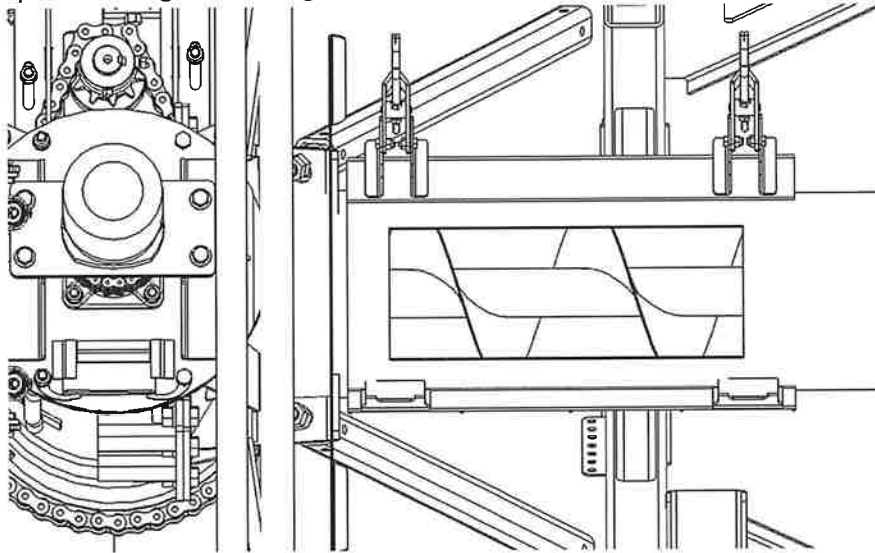

Figure 3

4. Using a 9/16" wrench or socket remove the 4 bolts and nuts shown in Figure 4 Below holding the hangar bearing in place. If the head of the bolt hits the vertical tube inside the access opening use the punch and hammer to drive the bolts out. This will allow the hangar bearing bracket to drop down.

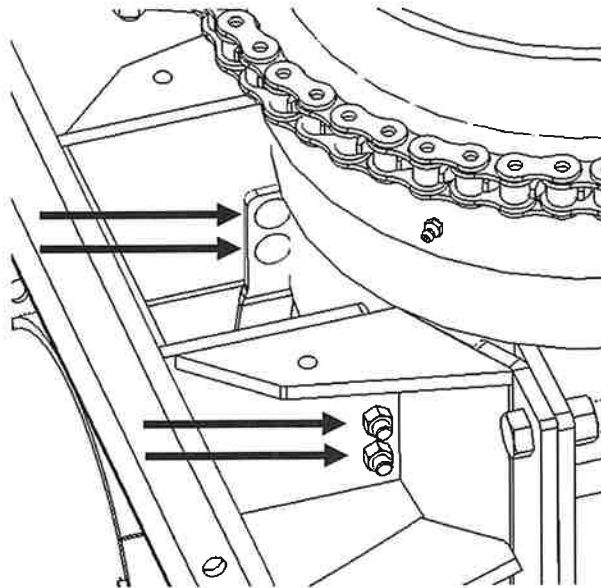

Figure 4

- 8.5 Drop the hanger bearing bracket down, rotate the bracket around the auger, and pull the bracket out of the tube as shown in Figure 5. Remove the bottom half of the hanger bearing and replace. If more space is needed to rotate the bracket around the auger use a vise grip or pipe wrench to rotate the auger flighting of the vertical auger and/or the bottom horizontal auger, the vertical auger flighting can be accessed from the back access door.

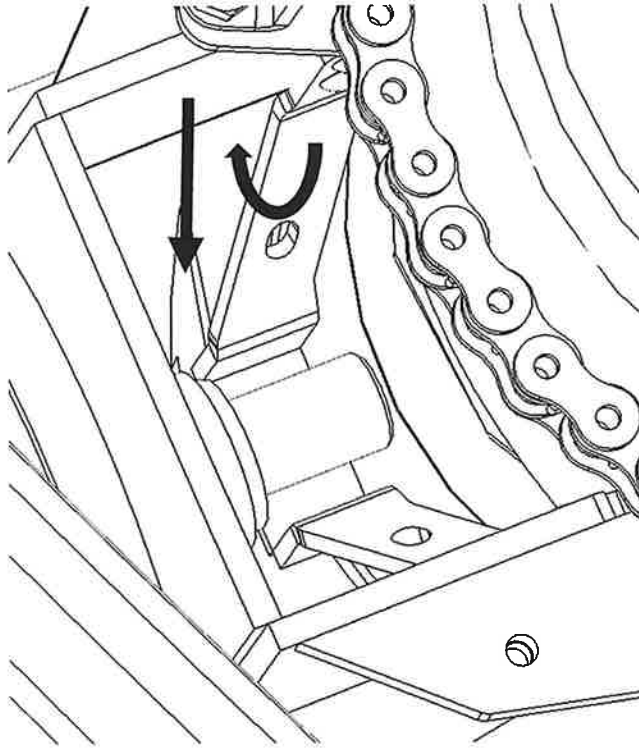

Figure 5

- 8.6 Reassemble the hanger bearing bracket back into place by following steps 8.1-8.5 in reverse order. Ensure the hanger bearing clears the auger flighting. Apply anti-seize to the bolts when reassembling in order to prevent the bolts from seizing in the future.

PARTS

DRIVER SIDE DISCHARGE DIMENSIONS

MT900TA TRAILER MOUNT SHOWN
(MT600TA AND MT900TA DIMENSIONS WILL BE SIMILAR)

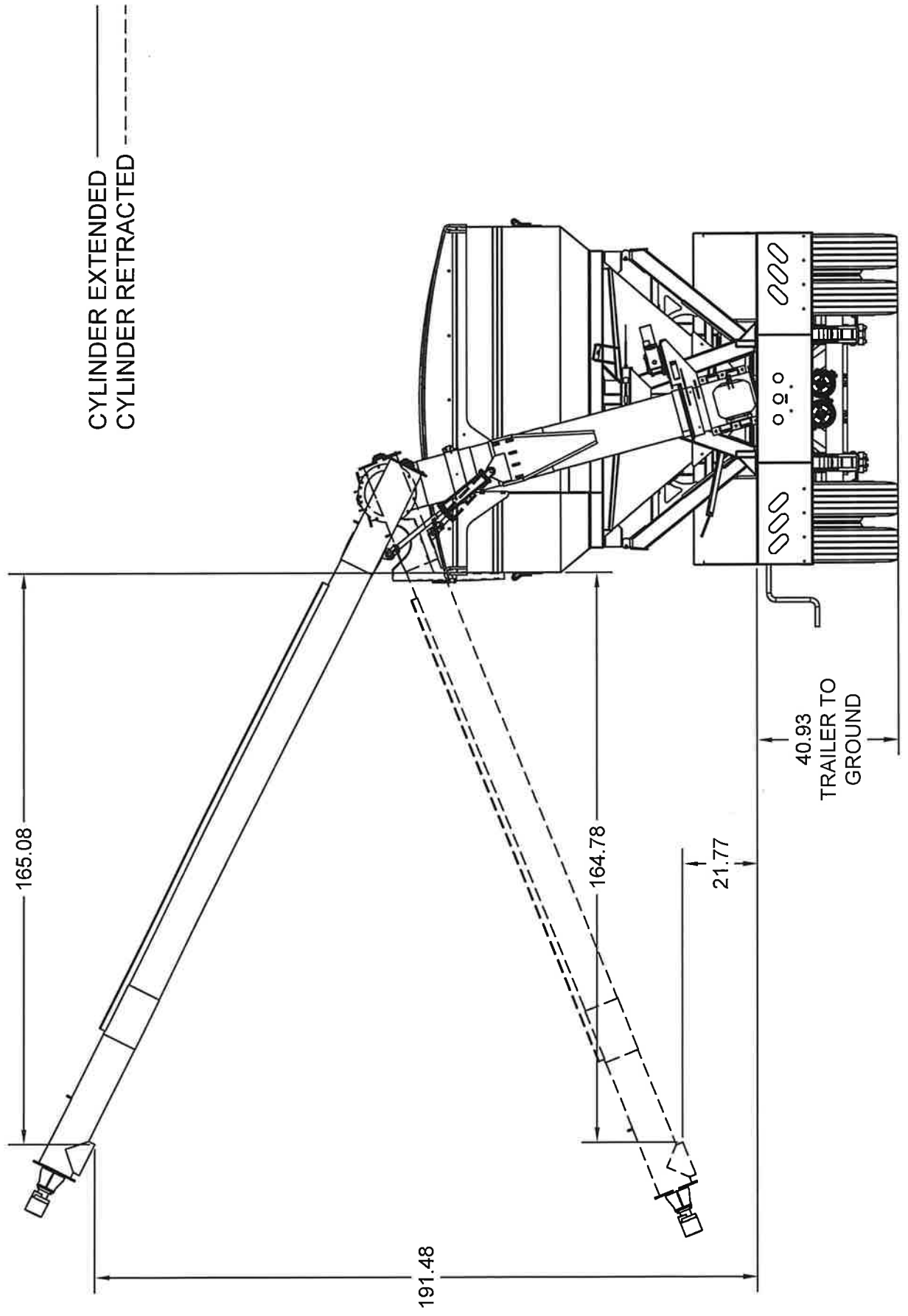

PASSENGER SIDE DISCHARGE DIMENSIONS

MT900TA TRAILER MOUNT SHOWN
(MT600TA AND MT900TA DIMENSIONS WILL BE SIMILAR)

CYLINDER EXTENDED ———
CYLINDER RETRACTED - - - - -

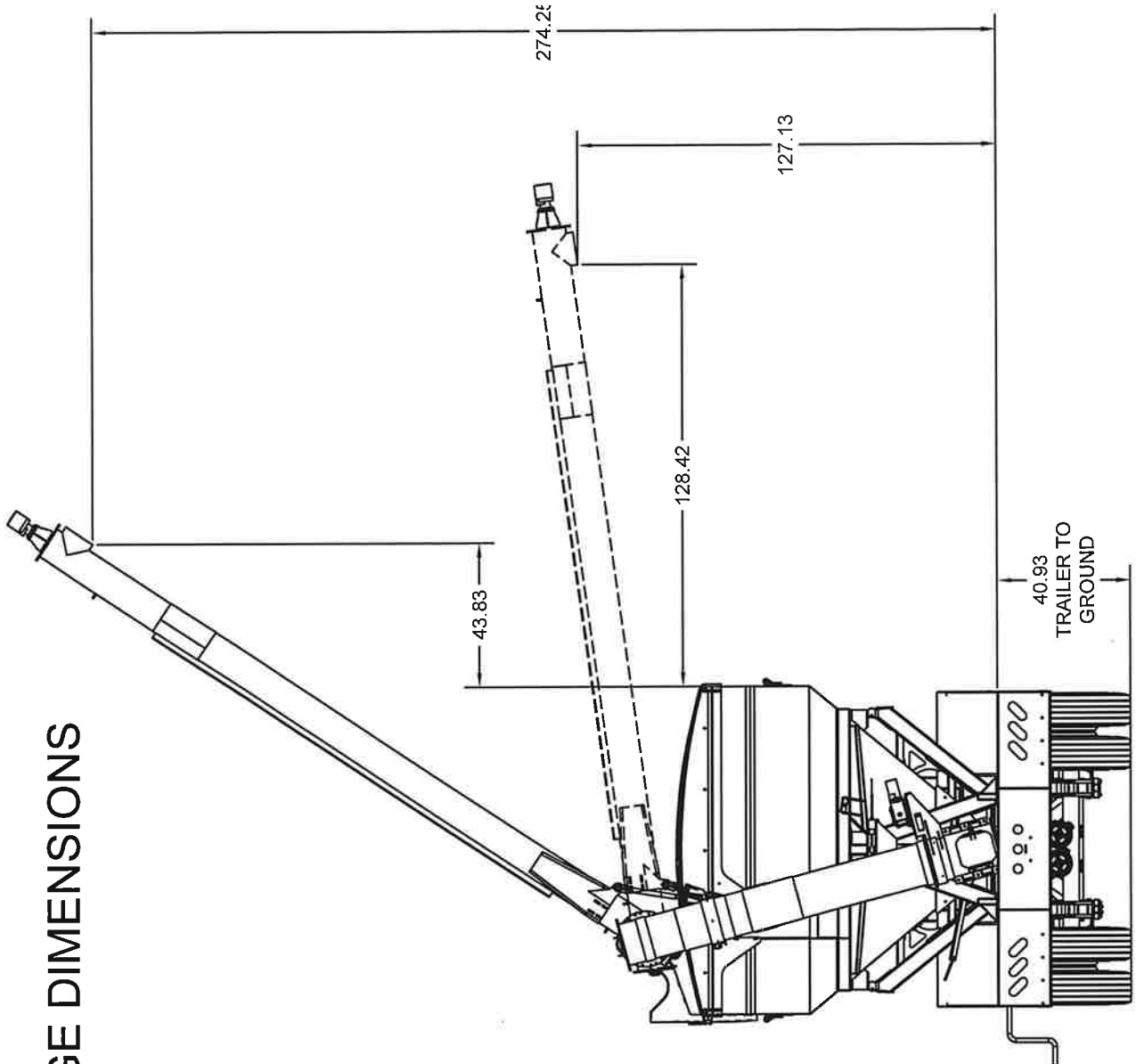

REAR DISCHARGE DIMENSIONS

MT900TA TRAILER MOUNT SHOWN
(MT600TA AND MT900TA DIMENSIONS WILL BE SIMILAR)

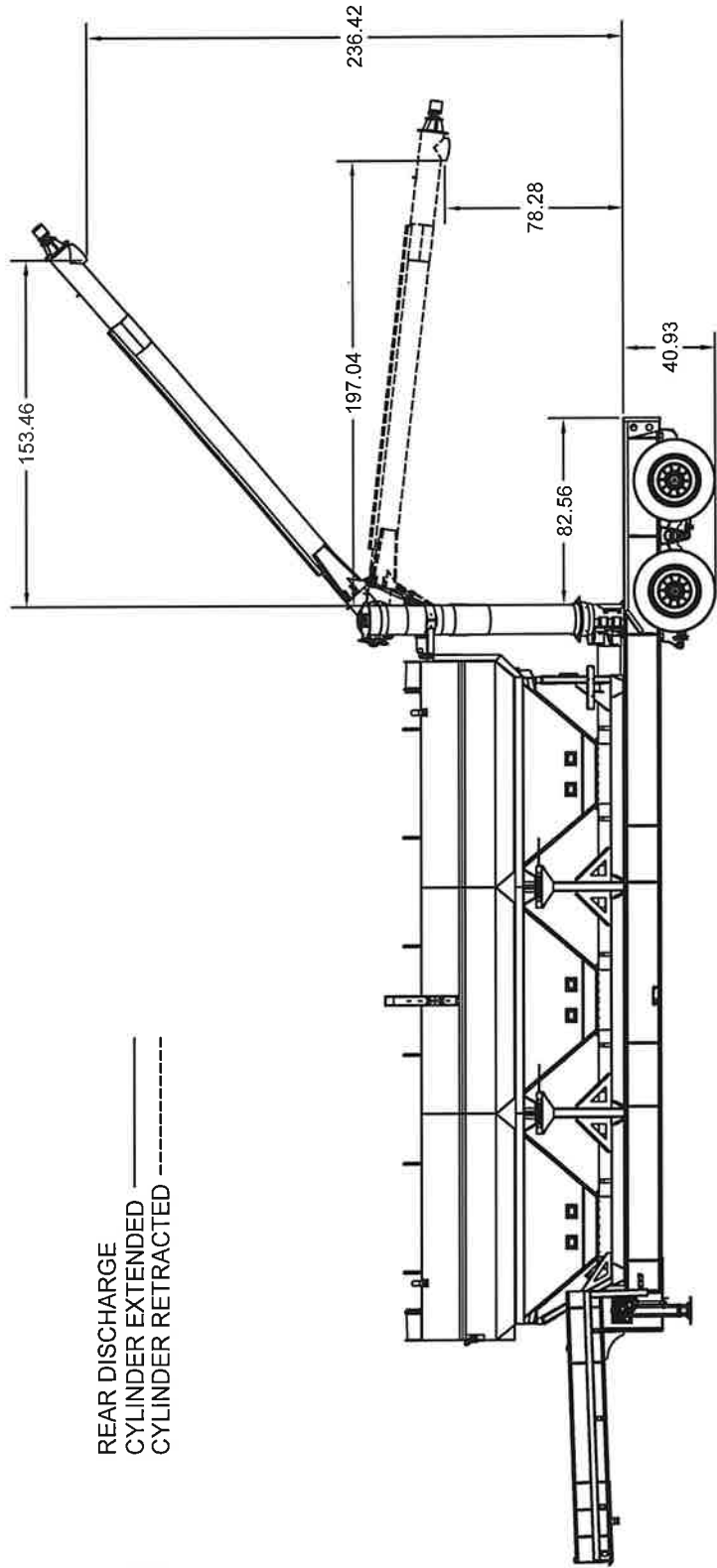
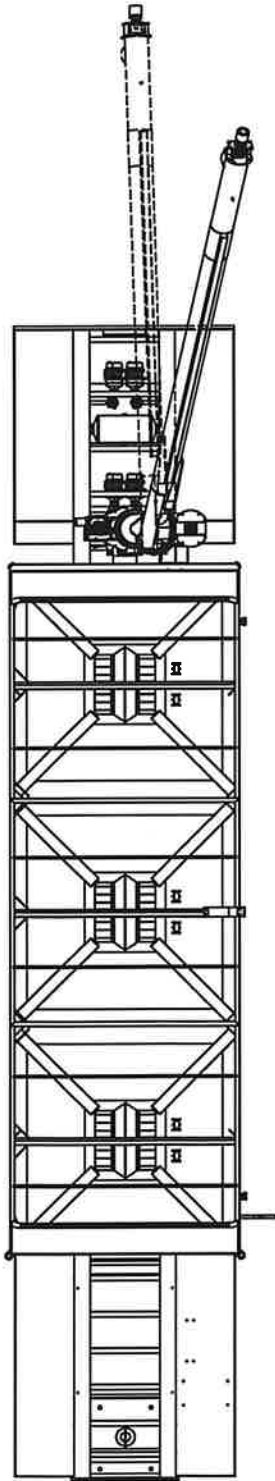

REAR DISCHARGE
CYLINDER EXTENDED ———
CYLINDER RETRACTED - - - - -

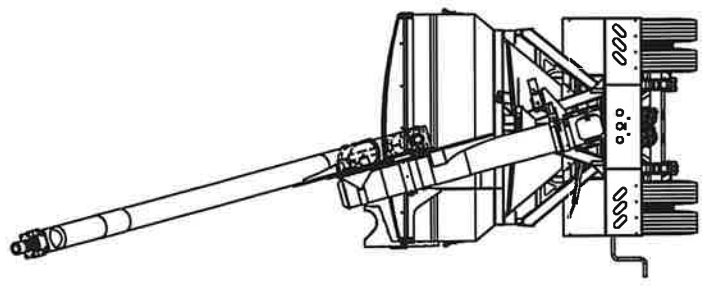

MT600 / MT900 LAYOUT DIMENSIONS

(3 HOPPER / 6 COMPARTMENT MT900 TRAILER MOUNT SHOWN)

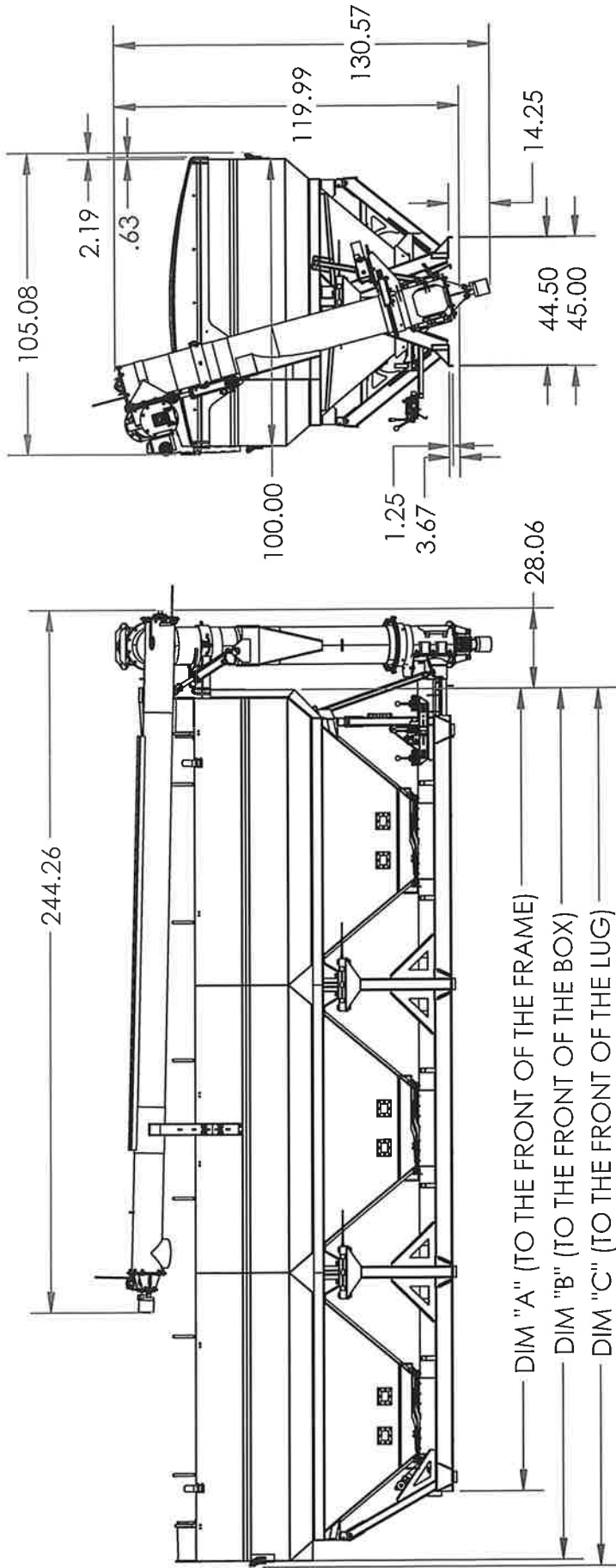

(FOR UNITS WITH FENDERS, THE FENDERS SHOULD MEASURE 96")

	DIM "A"	DIM "B"	DIM "C"
MT600 (TRUCK MOUNT)	203.50"	202.81"	205.03"
MT900 (TRUCK MOUNT)	303.50"	302.81"	305.03"
MT900 (TRAILER MOUNT)	279.12"	302.81"	305.03"

MT600TA MOUNTING EQUATION

MT600TA MOUNTED ON A TRUCK CHASSIS

STRUCK CAP. MT600TA TENDER, 600 CU.FT. X 62# (MATL) - 37200#

FERT. WT. ---- 37200#
UNIT WT. ---- 5800#

LOAD WT. ---- 43000#
DOES NOT INCLUDE
WT. OF TRUCK

FORMULA TO DETERMINE WT. PER AXLE.

$$\frac{\text{TOTAL LOAD X DIM "A"}}{\text{DIM "B" (WHL BASE)}} = \text{WT. ON FRONT AXLE}$$

EXAMPLE
43000 X 40 (DIM A) = 7610# ON FRONT AXLE
226 (DIM B)

$$\text{LOAD WT. MINUS WT. ON FRONT AXLE} = \text{WT. ON REAR AXLE}$$

EXAMPLE
43000 - 7610 = 35390# ON REAR AXLE

NOTE

INFO SHOWN TO BE USED AS A GUIDE ONLY. ACTUAL FIGURES MAY VARY DEPENDING ON TRUCK AXLES, WHEELBASE, CROSSMEMBER LOCATIONS, WT. OF TRUCK (NOT INCLUDED) ETC.

FOR HEAVIER DENSITY FERTILIZER AT 600 CU. FT CAPACITY, SHOULD ADD A 3RD AXLE

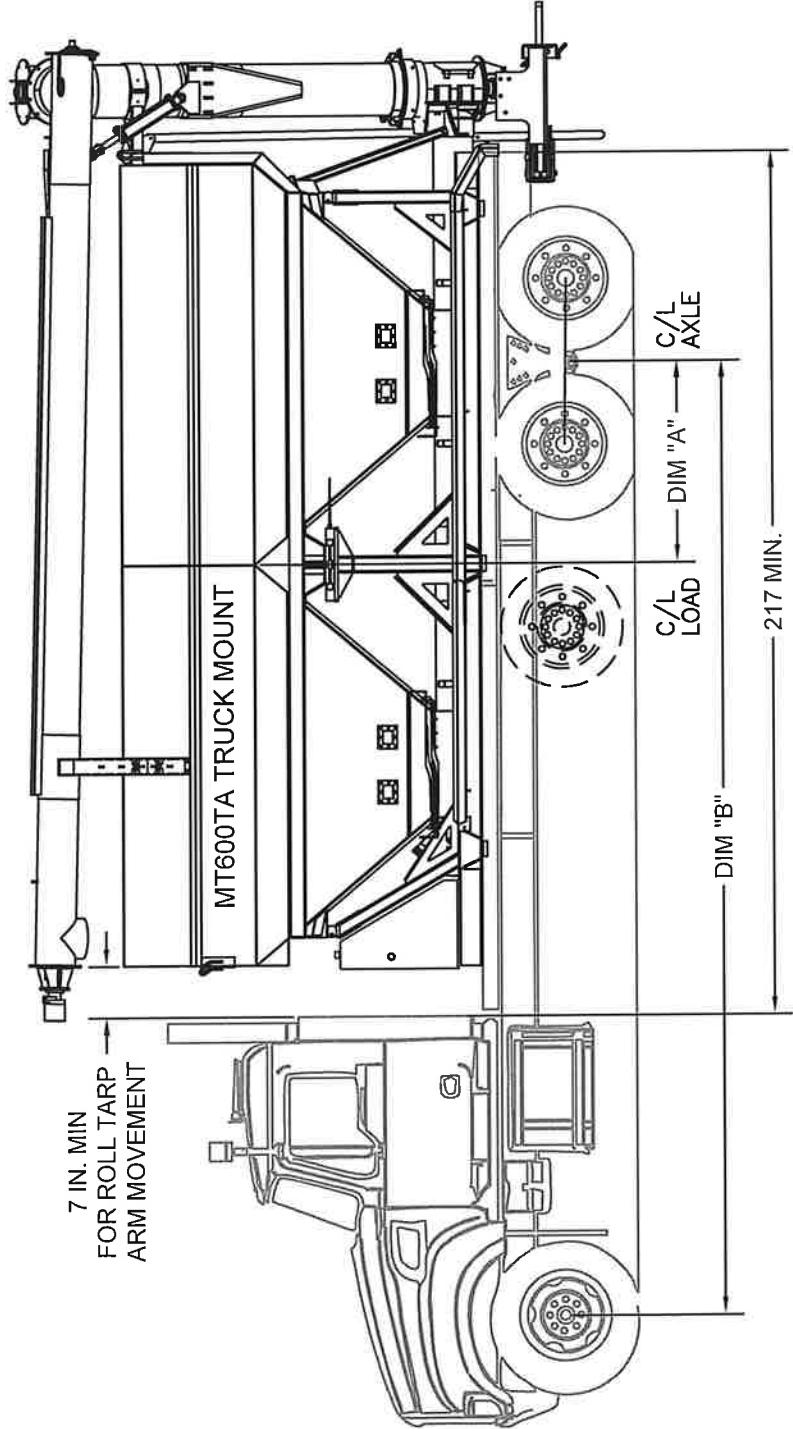

MT900TA MOUNTING EQUATION

MT900TA MOUNTED ON A TRUCK CHASSIS

STRUCK CAP. MT600TA TENDER,
900 CU.FT. X 62# (MATL) - 55800#

FERT. WT. ---- 55800#
UNIT WT. ---- 7800#

LOAD WT. ---- 63600#
DOES NOT INCLUDE
WT. OF TRUCK

FOR HEAVIER DENSITY
FERTILIZER AT 900 CU. FT
CAPACITY, SHOULD ADD
A 4TH AXLE

NOTE

INFO SHOWN TO BE USED
AS A GUIDE ONLY.
ACTUAL FIGURES MAY VARY
DEPENDING ON
TRUCK AXLES,
WHEELBASE,
CROSSMEMBER LOCATIONS,
WT. OF TRUCK
(NOT INCLUDED) ETC.

FORMULA TO DETERMINE WT. PER AXLE.

TOTAL LOAD X DIM "A"
DIM "B" (WHL BASE) = WT. ON FRONT AXLE

EXAMPLE
63600 X 50 (DIM A)
290 (DIM B) = 10966# ON FRONT AXLE

LOAD WT. MINUS WT. ON FRONT AXLE = WT. ON REAR AXLE

EXAMPLE
63600 - 10966 = 52634# ON REAR AXLE

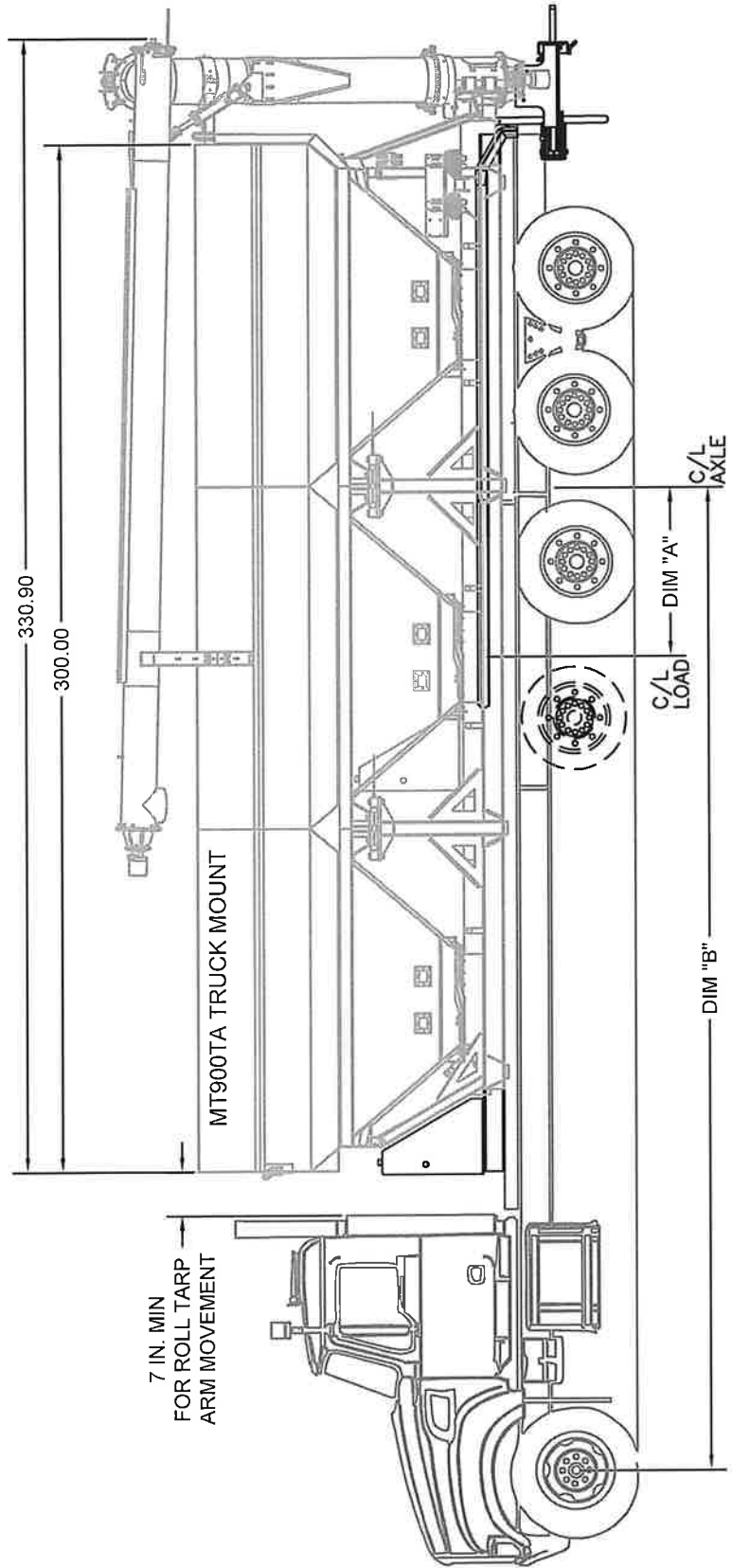

MT900TA TRAILER WEIGHT DISTRIBUTION EQUATION

G = Dimension from centerline of rear axle to center of gravity of load
 OAL = Dimension from centerline of wheel to centerline of rear axle
 TL = Load carried by truck
 TRAIL L = Load carried by trailer
 WT = Weight of Trailer, Tender, and Load.

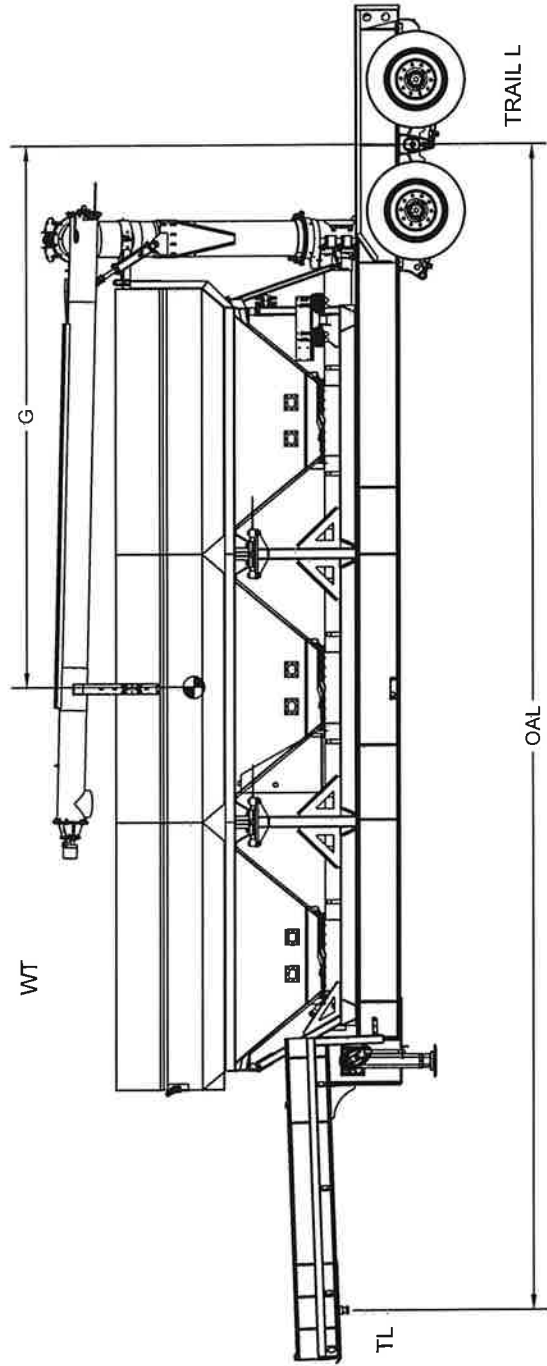

EXAMPLE G = 204.53" OAL = 453.71" WEIGHT = 64,000 LBS.	$TL = \frac{WT \times G}{OAL}$	$TL = \frac{64000 \times 204.53}{453.71}$	$TL = \frac{13089920}{453.71}$	$TL = 28850.85$
	$TRAIL L = WT - TL$	$TRAIL L = 64000 - 28850.85$		

MT900TA TRAILER AXLE SPACING EQUATION

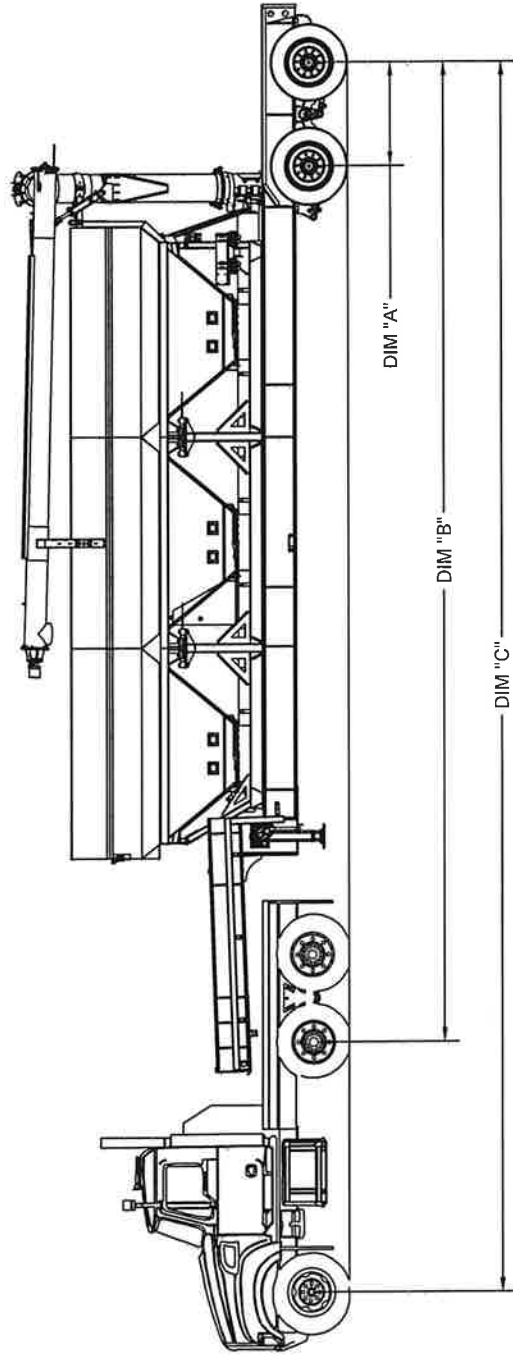

38

<p>DIM "A" = SPAN OF REAR TIRES (IN FEET)</p> <p>DIM "B" = SPAN FROM REAR TIRE OF TRAILER TO FRONT TIRE ON CENTRAL AXLE (IN FEET)</p> <p>DIM "C" = SPAN FROM REAR TIRE TO FRONT TIRE (IN FEET)</p> <p>N = NUMBER OF AXLES IN GROUP</p> <p>W= LOAD PER AXLE (ref. 500 lbs.)</p> $W \left(\frac{N \times \text{DIM "A, B, OR C"} }{N - 1} \right) + 12 \times N + 36$	<p>REAR AXLES</p> $W \left(\frac{N \times \text{DIM "A"} }{N - 1} \right) + 12 \times N + 36$ $500 \left(\frac{2 \times 4.083}{2 - 1} \right) + 12 \times 2 + 36$ $500 \left(\frac{8.16}{1} \right) + 24 + 36$ $500 (8.16 + 60)$ <p>500 X 68.16</p> <p>34080 LBS</p>	<p>REAR AND CENTER AXLE</p> $W \left(\frac{N \times \text{DIM "B"} }{N - 1} \right) + 12 \times N + 36$ $500 \left(\frac{4 \times 41.178}{4 - 1} \right) + 12 \times 4 + 36$ $500 \left(\frac{164.7}{3} \right) + 48 + 36$ $500 (54.9 + 84)$ <p>500 X 138.9</p> <p>69450 LBS</p>	<p>ALL AXLES</p> $W \left(\frac{N \times \text{DIM "C"} }{N - 1} \right) + 12 \times N + 36$ $500 \left(\frac{5 \times 52.511}{5 - 1} \right) + 12 \times 5 + 36$ $500 \left(\frac{262.6}{4} \right) + 60 + 36$ $500 (65.7 + 96)$ <p>500 X 161.7</p> <p>80,850 LBS</p>
--	--	--	--

MT900TA TENDER

BODY AND FRAME ILLUSTRATION
(TRAILER MOUNT IS SHOWN)

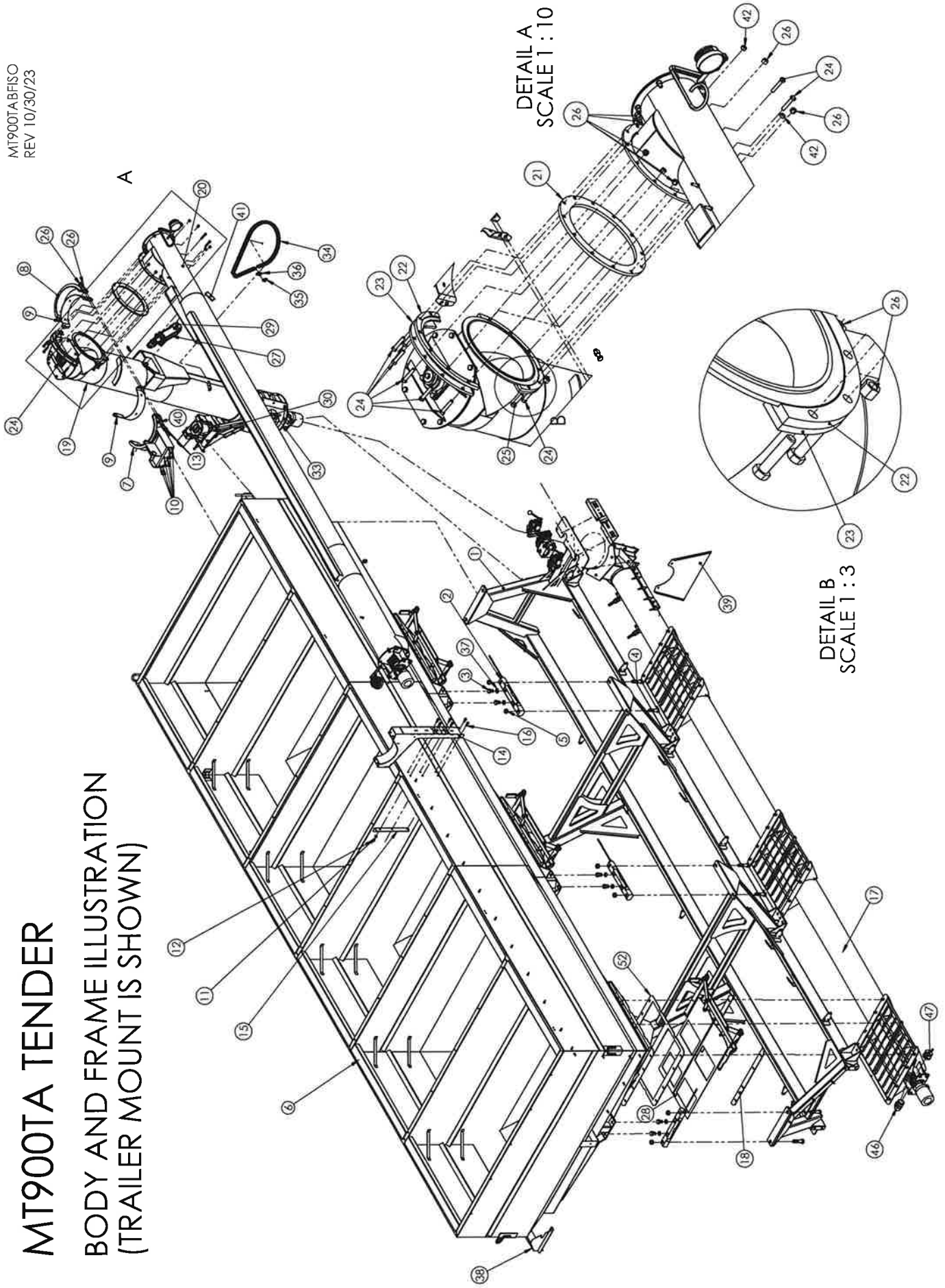

MT900TA TRAILER MOUNT BODY AND FRAME PARTS LIST

MT900BFLST
REV 10/30/23

ITEM NO.	PART NUMBER	DESCRIPTION	QTY
1	47076100 (SEE NOTE 2)	FRAME WELDMENT	1
2	SEE NOTE 1	SCALE PACKAGE	6
3	18059303M	BOLT HX CAP 24(3.0) X 70 (MAGNI 565)	12
4	18058501M	BOLT HX CAP G5NCZC 7/8 X 4 (MAGNI)	12
5	18458000M	NUT CTR LOCK 7/8 NC ZC (MAGNI 565)	12
6	47076070	HOPPER WELDMENT	1
7	47076324	WLDT, AUGER SUPPORT	1
8	76326	WELDT, VERT AUG. SUPPORT, OUTER	1
9	76478	GLIDE PLATE	2
10	18027416	BOLT CAP SS 1/2 X 1	6
11	18991400	WASHER LOCK 1/2 SS	7
12	18997400	NUT 1/2 SS	7
13	18470175	BOLT SS CAP 1/2 X 1 3/4	4
14	47076360	AUGER CRADLE WLDMT	1
15	76373	MOUNTING ANGLE #1	2
16	18475240	BOLT SS CAP 1/2 X 1 1/4	7
17	SEE PAGES 45-46	LOWER AUGER	1
18	76440	HOPPER SPACER	6
19	SEE PAGES 55-56	VERTICAL AUGER w/ TRANSITION BOOT	1
20	SEE PAGES 57-58	UNLOAD AUGER ASSY	1
21	76322	UNLOAD BEARING	1
22	76338	UNLOAD BEARING, NYLON	2
23	76339	HOUSING, FLANGE	2
24	18027436	BOLT SS CAP 1/2 X 2 1/2	10
25	18477432	BOLT SS CAP 1/2 X 2 1/4	2
26	18567400	NUT SS NYLOCK 1/2	20
27	47005491	3 X 14 CYLINDER	1
28	SEE PAGES 59-60	SLIDING DOOR	3
29	1012830	COUNTER BALANCE LOCK	1
30	47076295	WLDT, AUGER SUPPORT	2
31	18098500M	BOLT HX 3/4 X 1 3/4 G8 NC ZC (MAGNI)	2
32	18098462M	BOLT HX 3/4 X 6 NF B7 FULL (MAGNI)	2
33	18418400M	NUT HX 3/4 NF ZP G5 (MAGNI 565)	8
34	30180	#80 ROLLER CHAIN 62" LENGTH	5.5
35	30080	HALF LINK	1
36	30280	#80 CHAIN CONNECTOR LINK	1
37	18892100M	WASHER LOCK M24 ZC (MAGNI 565)	12
38	47076665	SHIELD	3
39	76684	BIB	1
40	200781	1/8 STREET ELBOW SS	4
41	76667	PRESSURE RELIEF MOUNT	1
42	18577400	NUT 1/2 NC SS JAM	2
43	76718	NAME PLATE	1
44	1132237	SINGLE SPOOL VALVE	1
45	1131625	DUAL SPOOL VALVE	1
46	200208	2" COUPLER 90 DEG ELBOW	1
47	200172	2" FEMALE COUPLER CAP	1
48	18025718	BOLT CAP SS 1/4 X 3/4	6
49	18569200	NUT 1/4 NYLOCK SS	6
50	18881001	WASHER FLAT 1/4 SS	6
51	1191269	SINGLE SPOOL VALVE, CLOSED	1
52	71939	HOPPER GATE SHIM	3

47076957 - REAR HOPPER AUGER CRADLE SUB ASSEMBLY
CONTAINS ITEMS 7-10, 13, & 40, ALSO QTY 10 OF ITEM 26(18567400)

NOTE 1: IF SCALE PACKAGE IS REQ'D ORDER P/N: 48009000 QTY 1 (INC: CELLS, CONTROLS, AND WIRING SEE PAGES 43-44)
IF SCALE PACKAGE IS NOT REQUIRED ORDER P/N: 76483 WEIGH BAR FILL QTY 6.

NOTE 2: 47076100 IS THE TRAILER MOUNT FRAME / 47076703 IS THE TRUCK MOUNT FRAME (SEE PAGES 41-42)

MT900TA TENDER DRIVER SIDE ILLUSTRATION

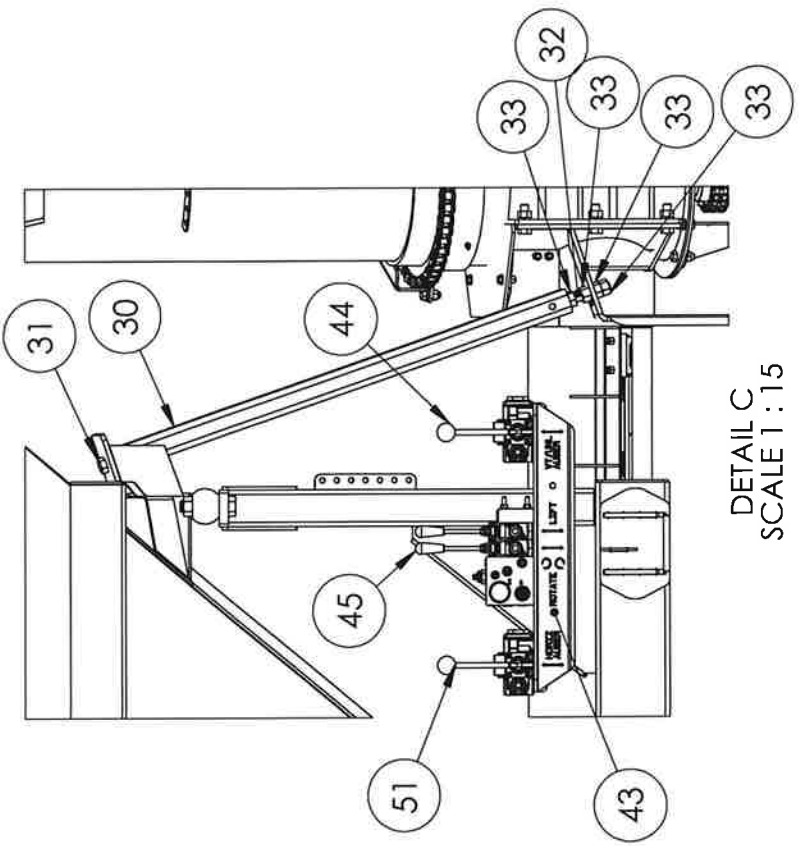
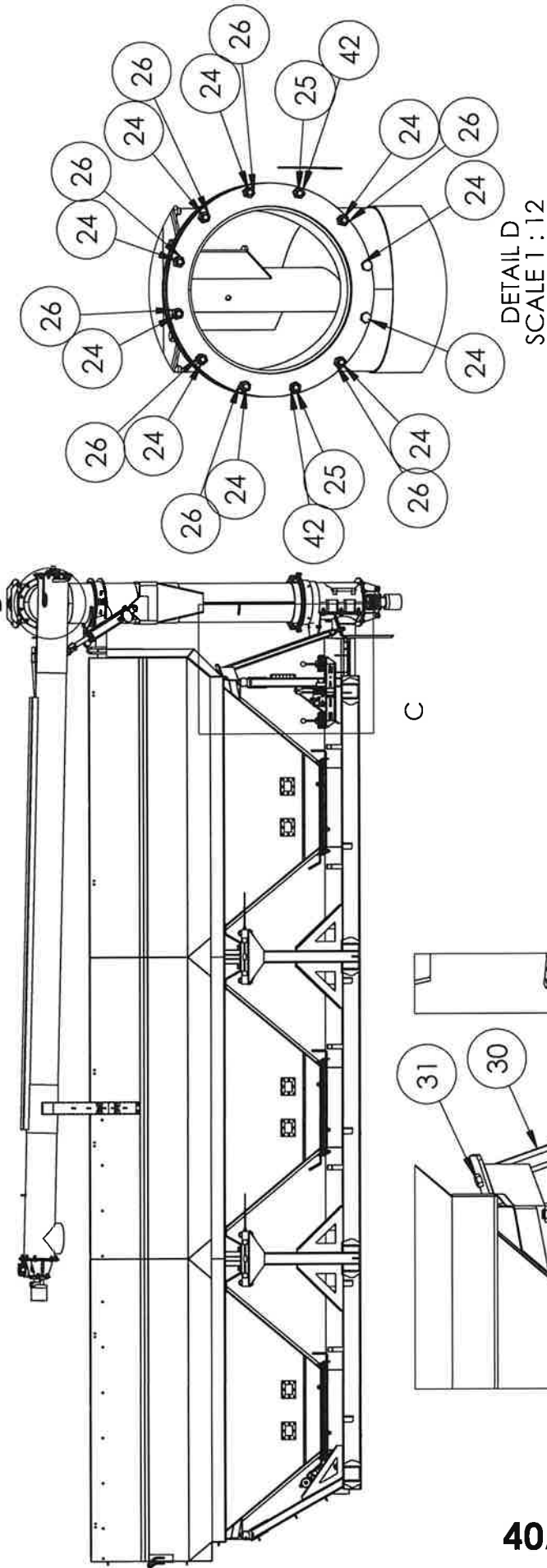

40A

ITEM NO.	PART #	DESCRIPTION	Default /QTY.
24	18027436	BOLT SS CAP 1/2 X 2 1/2	10
25	18477432	BOLT SS CAP 1/2 X 2 1/4	2
26	18567400	NUT SS NYLOCK 1/2	20
30	47076295	WLDT, AUGER SUPPORT	2
31	18098500M	BOLT HX 3/4 X 1 3/4 G8 NC ZC (MAGNI)	2
32	18098462M	BOLT HX 3/4 X 6 NF B7 FULL (MAGNI)	2
33	18418400M	NUT HX 3/4 NF ZP G5 (MAGNI 565)	8
42	18577400	NUT 1/2 NC SS JAM	2
43	76718	NAME PLATE	1
44	1132237	SINGLE SPOOL VALVE	1
45	1131625	DUAL SPOOL VALVE	1
51	1191269	SINGLE SPOOL VALVE, CLOSED	1

MT900TA TENDER PASSENGER SIDE ILLUSTRATION

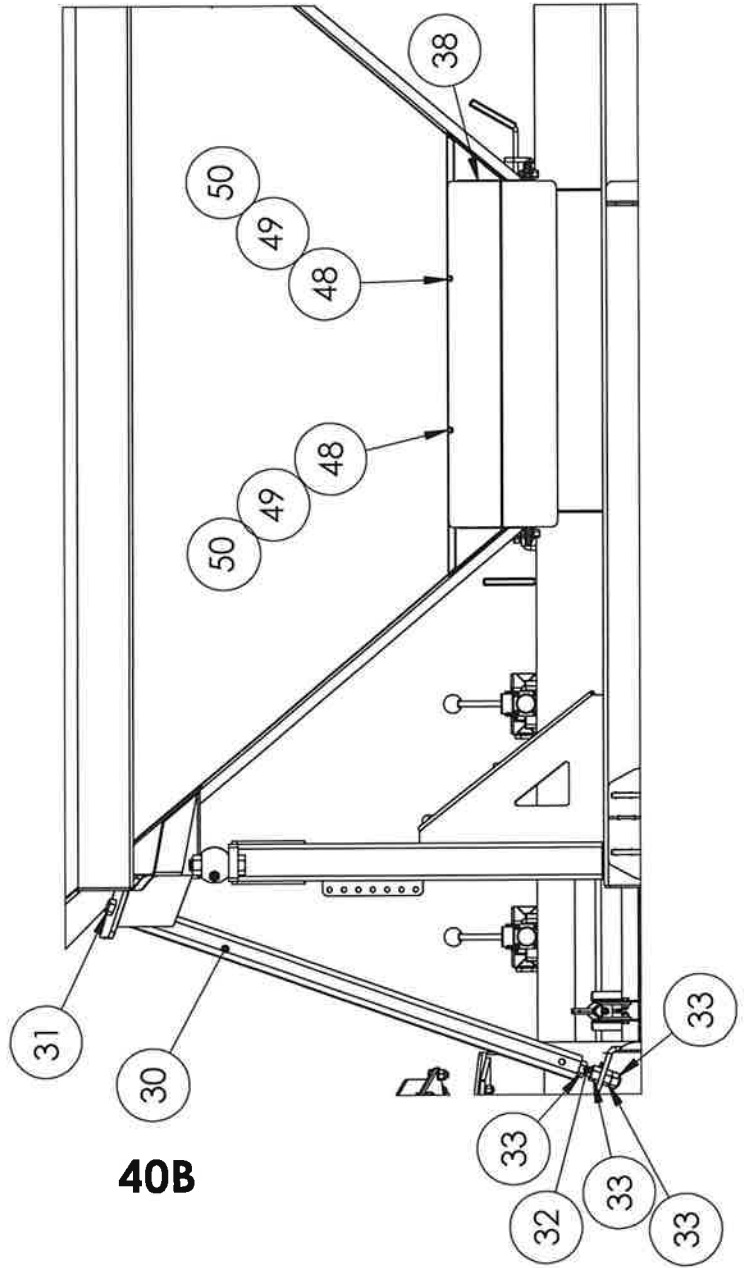
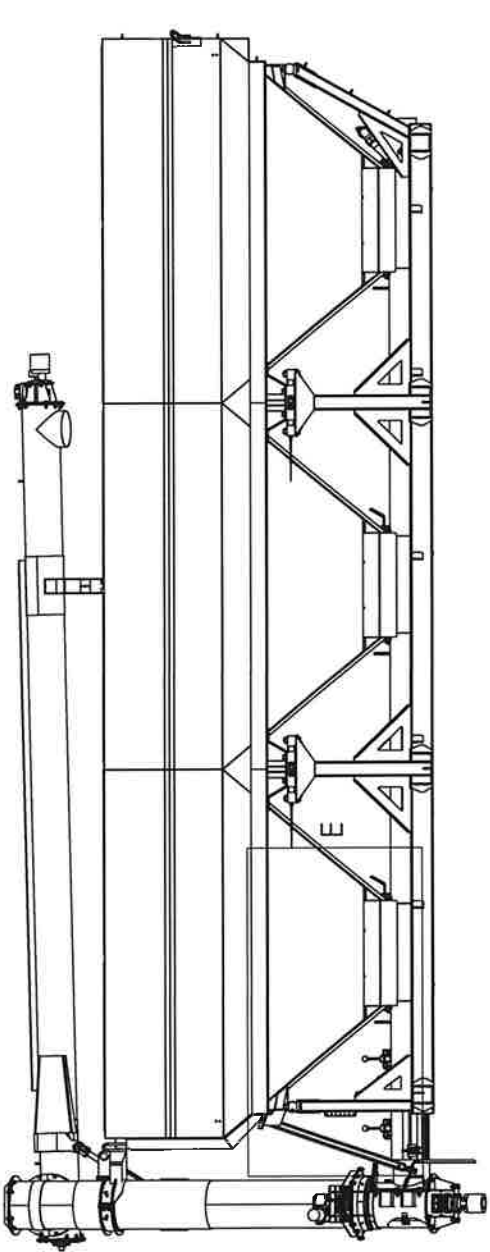

ITEM NO.	PART NUMBER	DESCRIPTION	Defa ult/QT Y.
30	47076295	WLDT, AUGER SUPPORT	2
31	18098500M	BOLT HX 3/4 X 1 3/4 G8 NC ZC (MAGNI)	2
32	18098462M	BOLT HX 3/4 X 6 NF B7 FULL (MAGNI)	2
33	18418400M	NUT HX 3/4 NF ZP G5 (MAGNI 565)	8
38	47076665	SHIELD	3
48	18025718	BOLT CAP SS 1/4 X 3/4	6
49	18569200	NUT 1/4 NYLOCK SS	6
50	18881001	WASHER FLAT 1/4 SS	6

DETAIL
SCALE 1:15

**MT900 TRUCK MOUNT
(CONVERSION KIT) PART ILLUSTRATION
2021 & NEWER
P/N: 71338**

(PRE 2021 USED SOLID FRAME P/N:47076703)

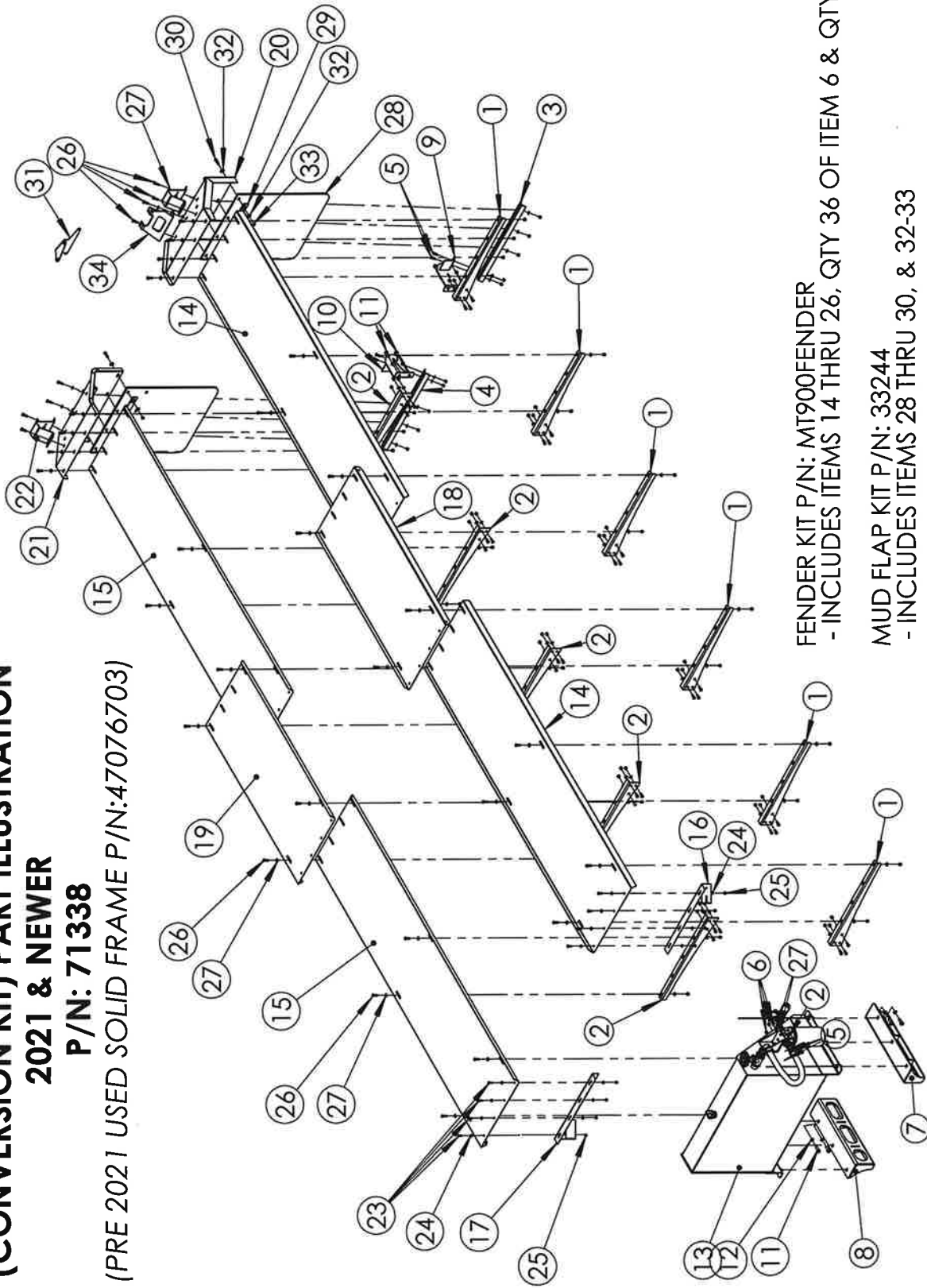

FENDER KIT P/N: MT900FENDER
- INCLUDES ITEMS 14 THRU 26, QTY 36 OF ITEM 6 & QTY 72 OF ITEM 27

MUD FLAP KIT P/N: 33244
- INCLUDES ITEMS 28 THRU 30, & 32-33

MT900 TRUCK MOUNT (CONVERSION KIT) PART LISTING 2021 & NEWER P/N: 71338

IN USE CONFIGURATION
(SHOWN WITH FRAME)

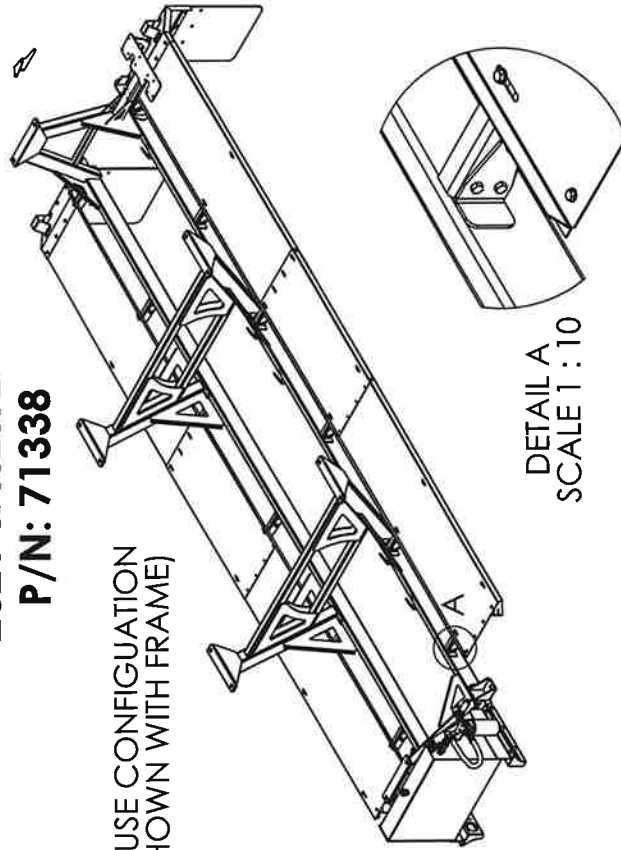

DETAIL A
SCALE 1 : 10

ITEM NO.	PART NUMBER	DESCRIPTION	QTY.
1	71213	FENDER MOUNT	6
2	71214	FENDER MOUNT	6
3	71216	REAR LEG	1
4	71217	REAR LEG	1
5	18026822	BOLT, HEX HD 3/8 X 1 NC SS	40
6	18566400	NUT SS NYLOCK 3/8	76
7	71439	OIL TANK MOUNT #1	1
8	71423	OIL TANK MOUNT #2	1
9	71429	REAR FENDER MOUNT #1	1
10	71430	REAR FENDER MOUNT #2	1
11	18057426	BOLT, HX CAP 1/2-13 X 1 1/2 LG	8
12	18891400	WASHER, 1/2 LOCK ZC	8
13	47976641	TRUCK MOUNTED OIL TANK W/ FITTINGS	1
14	28815	FENDER, LH	2
15	28816	FENDER RH	2
16	28163	LIGHT BRKT FRONT LH	1
17	28164	LIGHT BRKT FRONT, RH	1
18	47076642	LEFT SHORT FENDER	1
19	47076643	LEFT SHORT FENDER	1
20	47076632	QUARTER PANEL LH	1
21	47076631	QUARTER PANEL RH	1
22	76721	LIGHT BRKT REAR	2
23	18026422	BOLT CAP SS 5/16 X 1	8
24	18991100	WASHER, FLAT 5/16 SS	16
25	18457500	NUT 5/16-18 NYLOCK	8
26	18026824	BOLT HX SS 3/8 X 1 1/4	36

ITEM NO.	PART NUMBER	DESCRIPTION	QTY.
27	18991200	WASHER FLAT 3/8 SS	112
28	76714	MUD FLAP	2
29	47006302	MOUNTING STRAP	2
30	18056826	BOLT HX NC ZC 3/8 X 1 1/2	8
31	76720	REAR LIGHT BRACKET	1
32	18811200	WASHER FLAT USS ZC 3/8	16
33	18459200	NUT 3/8 NYLOCK	8
34	71794	FENDER SUPPORT BRACKET WELDT	1

MT900 SCALE PACKAGE

PART #:48009000

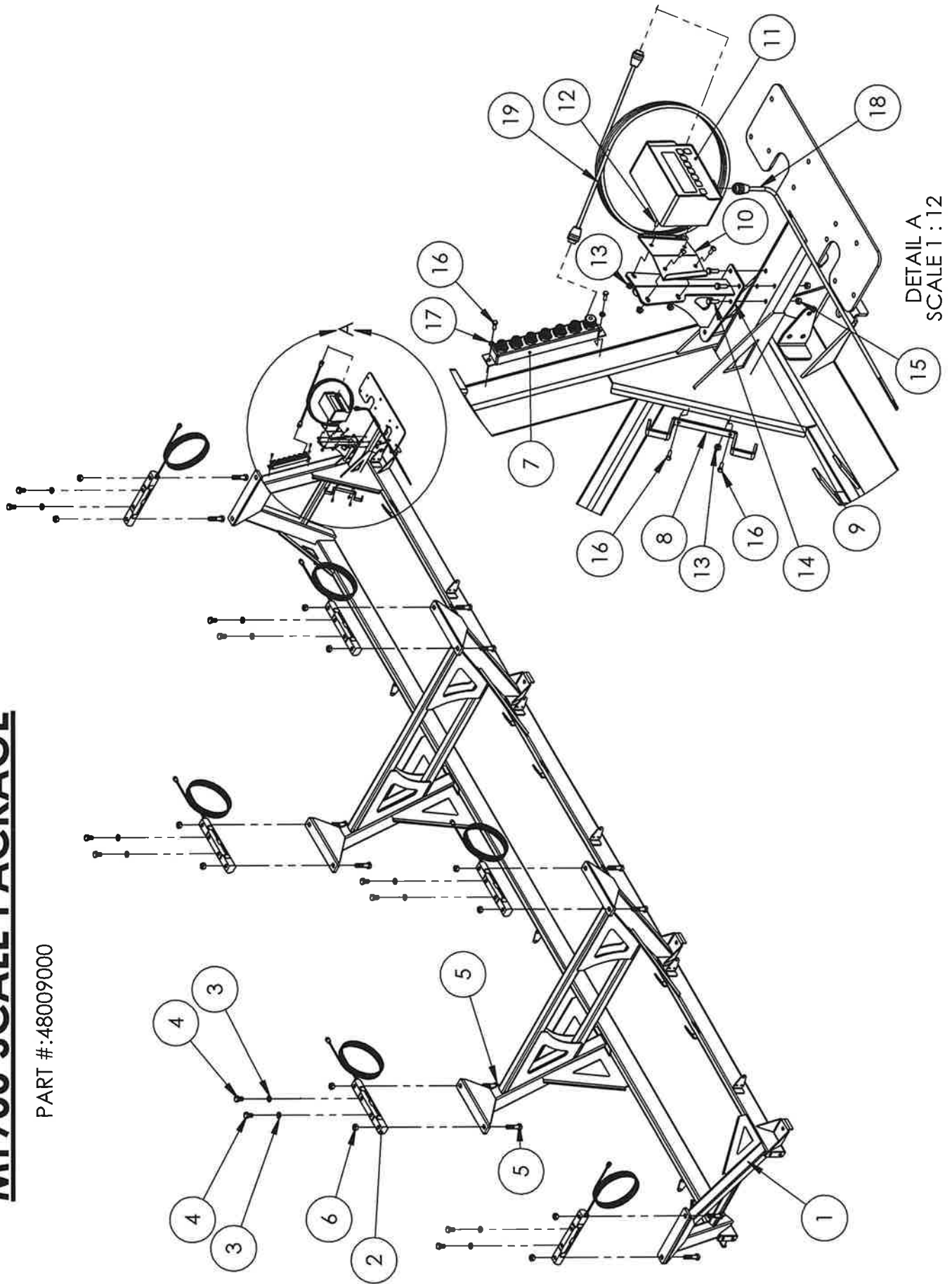

DETAIL A
SCALE 1 : 12

MT900 SCALE PACKAGE

PART #:48009000

ITEM NO.	PART NUMBER	DESCRIPTION	QTY.
1	47076100	FRAME WELDMENT	1
2	AWT27-500205	WEIGH BAR, DOUBLE END FLAT W/ 30 FT CABLE 5 PIN AWT CONN.	6
3	18892100M	WASHER LOCK M24 ZC (MAGNI 565)	12
4	18059303M	BOLT HX CAP 24(3.0) X 70 (MAGNI 565)	12
5	18058501M	BOLT HX CAP G5NCZC 7/8 X 4 (MAGNI)	12
6	18458000M	NUT CTR LOCK 7/8 NC ZC (MAGNI 565)	12
7	50040-0015	6 BAR J-BOX W/5 PIN AWT CONNECTORS	1
8	47009766	BRACKET, LOAD CELL CABLES	1
9	47076730	SCALE STAND	1
10	76597	SCALE HEAD PLATE	1
11	640MS5P-640M	INDICATOR 5 PIN AWT CONNECTOR	1
12	18706423	SCREW, SLOTTED TRUSS HEAD 1/4 X 3/4 SS	4
13	18971400	NUT SER FLG SS 1/4	6
14	18026422	BOLT CAP SS 5/16 X 1	4
15	18457500	NUT 5/16-18 NYLOCK	4
16	18025718	BOLT CAP SS 1/4 X 3/4	4
17	18991000	WASHER LOCK 1/4 SS	2
18	19266-0058	18FT POWER CORD AWT W/ TINNED LEADS	1
19	28755-0032	25FT INTERFACE CABLE WITH 5 PIN CONNECTORS EACH END	1

NOTES:

1. ITEMS 1,3,4,5, AND 6 ARE NOT INCLUDED IN THE PACKAGE
2. SCALE PACKAGE IS IDENTICAL FOR TRUCK AND TRAILER MOUNT, ONLY THE FRAME IS DIFFERENT
3. ALSO REQUIRED (BUT NOT SHOWN), ARE QTY. 50 OF P/N #21245 - CABLE TIE MOUNTING BASE (BLACK)

ELECTRICAL POWER SUPPLY:

- FOR TRUCK MOUNTED UNITS HOOK TO TRUCK BATTERY
- FOR TRAILER MOUNTED TENDER W/ KUBOTA ENGINE PACKAGE, HOOK TO KUBOTA'S BATTERY
- **(OPTIONAL)** FOR FELLING TRAILERS HOOK DIRECTLY TO STUDDED JUNCTION BOX **P/N: AC2831**, LOCATED IN FRONT OF THE REAR AXLE

(FOR SCALE PACKAGE WHITE WIRES ARE POWER/ BLACK WIRES ARE GROUND)

CONFIGURE CALIBRATION NUMBER FOR MODEL 640 INDICATOR

(Information supplied by Avery Weigh-Tronix)

Procedure to configure calibration number in a 640 Series Indicator:

1. Press and hold the **HOLD/MENU** button for 3 beeps and release
2. *SET.PAS* will appear on the display
 - a. Use the **RM** and **M+** buttons to enter in the password 640 (To advance to next character press the **HOLD/MENU** button)
3. Once 640 is displayed on the display press the **PRINT SELECT** button
4. 640 will appear on the display with all annunciators one around the display
5. Press the **PRINT SELECT** button
6. *CONFIG* will appear on the display
7. Press the **PRINT SELECT** button
 - a. Use the **RM** and **M+** buttons to enter in the Config Code 98300 (To advance to next character press the **HOLD/MENU** button)
8. Once 98300 is displayed on the display press the **PRINT SELECT** button
9. *CONFIG* will appear on the display
10. Press the **HOLD/MENU** button once
11. *CUSTOM* will appear on the display
12. Press the **PRINT SELECT** button
13. Use the **RM** and **M+** buttons to enter one of the following codes (To advance to next character press the **HOLD/MENU** button)
 - a. 4 Bar System using part number AWT27-500229 (Spreaders and 6500 Applicators)
 - i. Custom Code number is 32000
 - b. 4 Bar System using part number AWT27-500205 (MT600 Tender)
 - i. Custom Code number is 36904
 - c. 6 Bar System using part number AWT27-500205 (MT900 Tender)
 - i. Custom Code number is 55356
14. Once the correct code number is displayed press the **PRINT SELECT** button once
15. *CUSTOM* will appear on the screen
16. Press the **G/N** button until display says *BUSY*
17. Your configuration is complete

It seems like a lot of steps, but this process should take less than one minute.

(For further inquiries/details, please consult your Avery Weigh-Tronix manual.)

MT900 LOWER AUGER TUBE ILLUSTRATION

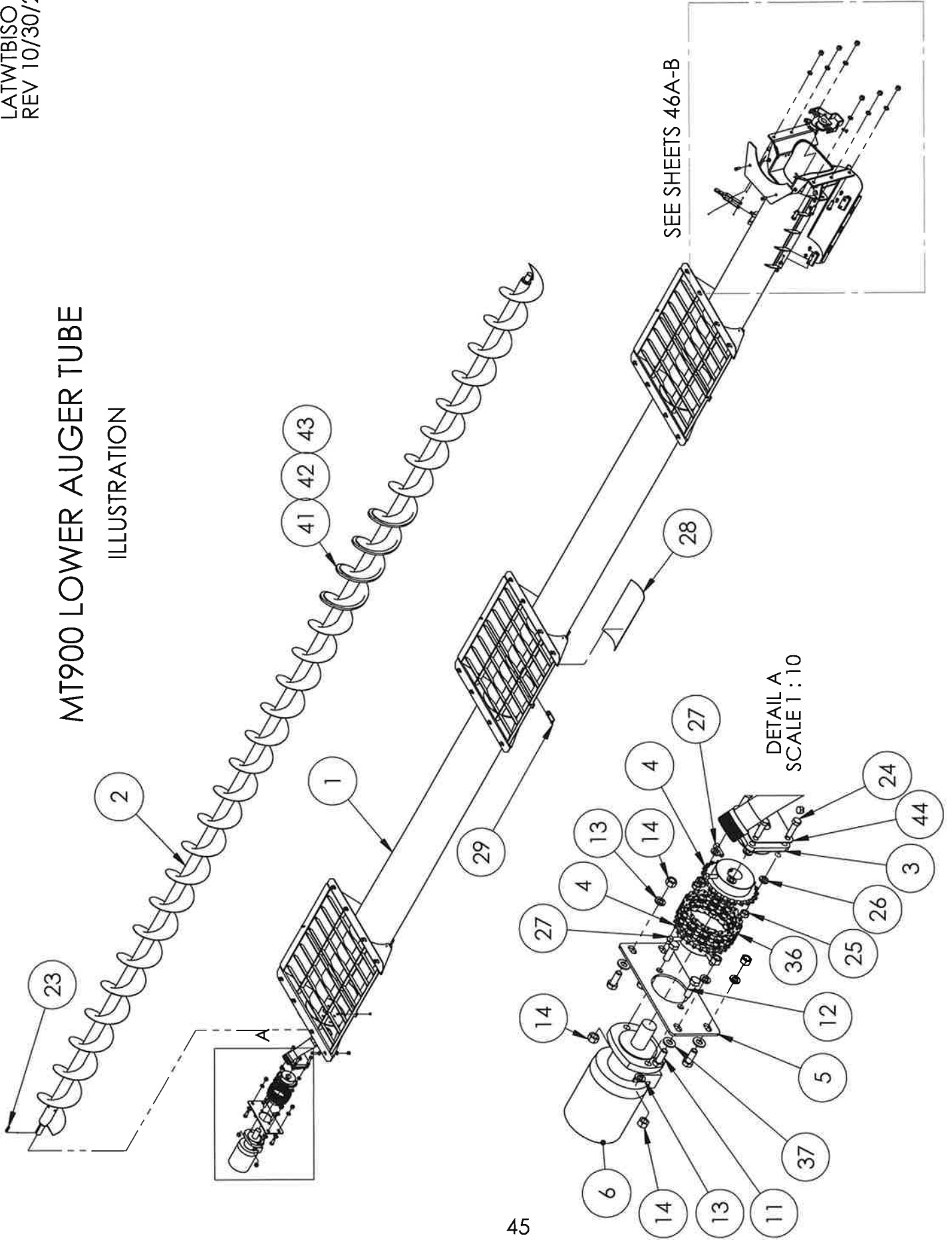

MT900 LOWER AUGER TUBE

LATWTBLST
REV 10/30/23

PART LIST

ITEM NO.	PART NUMBER	DESCRIPTION	QTY.
1	47076075	AUGER WELDMENT	1
2	47076074	AUGER FLIGHTING WELDMENT	1
3	10649	4-BOLT FLANGE BEARING, 1.25" SHAFT	1
4	48300151	24 TOOTH SPROCKET #50 CHAIN 1 1/4" BORE 5/16 KEY	2
5	76444	PLATE MOTOR	1
6	1040020	MOTOR HYDRAULIC (LOWER AUGER)	1
7	47076402	SUPPORT HANGER BEARING	1
8	76401	STRAP RETAINER	1
9	RHB203631	WOOD BEARING	1
10	18566400	NUT SS NYLOCK 3/8	36
11	18475240	BOLT HX CAP 1/2-13 X 1 1/4 LG SS	4
12	18022026	BOLT SS HX 1/2 X 1 1/2	2
13	18991400	WASHER LOCK 1/2 SS	6
14	18997400	NUT 1/2 SS	6
15	76400	PLATE COVER	1
16	18055501	BOLT CARRIAGE SS 3/8-16 X 1 1/4" LG	4
17	18026824	BOLT HX SS 3/8 X 1 1/4	26
18	18997930	BOLT HX SS 5/8 X 2	6
19	18971600	WASHER LOCK 5/8 SS	6
20	18477500	NUT 5/8 SS	6
21	18025720	BOLT CAP SS 1/4 X 1	6
22	18569200	NUT 1/4 NYLOCK SS	6
23	37265	KEY	1
24	18997650	BOLT HX SS 7/16 X 1 1/2	4
25	18997100	NUT HX SS 7/16 NC	4
26	18991300	WASHER LOCK 7/16 SS	4
27	18767449	SCREW SET 5/16 X 1 SQHD NCSC	4
28	47076663	SLIDING DOOR	3
29	18000099	5/16 X 1 3/4 DBL WIRE RND	3
30	47076359	WLDT, CLEAN OUT DOOR	1
31	47076343	WLDT, HINGE	2
32	76551	HOLD DOWN ROD	2
33	18026418	BOLT CAP SS 5/16 X 3/4	4
34	18476351	NUT HX SS 5/16 SELF LOCK	8
35	18996818	BOLT HX SS 3/8 X 3/4 NC	4
36	29941	CHAIN COUPLER	1
37	18824800	WASHER, FLAT 1/2 SS	8
38	18991200	WASHER FLAT 3/8 SS	50
39	18026822	BOLT, HEX HD 3/8 X 1 NC SS	2
40	47076736	DUMP DOOR LATCH	2
41	76771	UHMW EDGING	1
42	18704218	SCREW MACH RD PH SS 8-32 X 3/4	9
43	18474201	NUT HX NYLOCK #8/32 SS	9
44	71790	BEARING GUARD, 1.25" SHAFT	1

WHEN ORDERING A REPLACEMENT BEARING (ITEM#3), ALSO ORDER GREASE FITTING ADAPTER P/N: 1128526

MT900 LOWER AUGER REAR DETAIL (DRIVER SIDE)

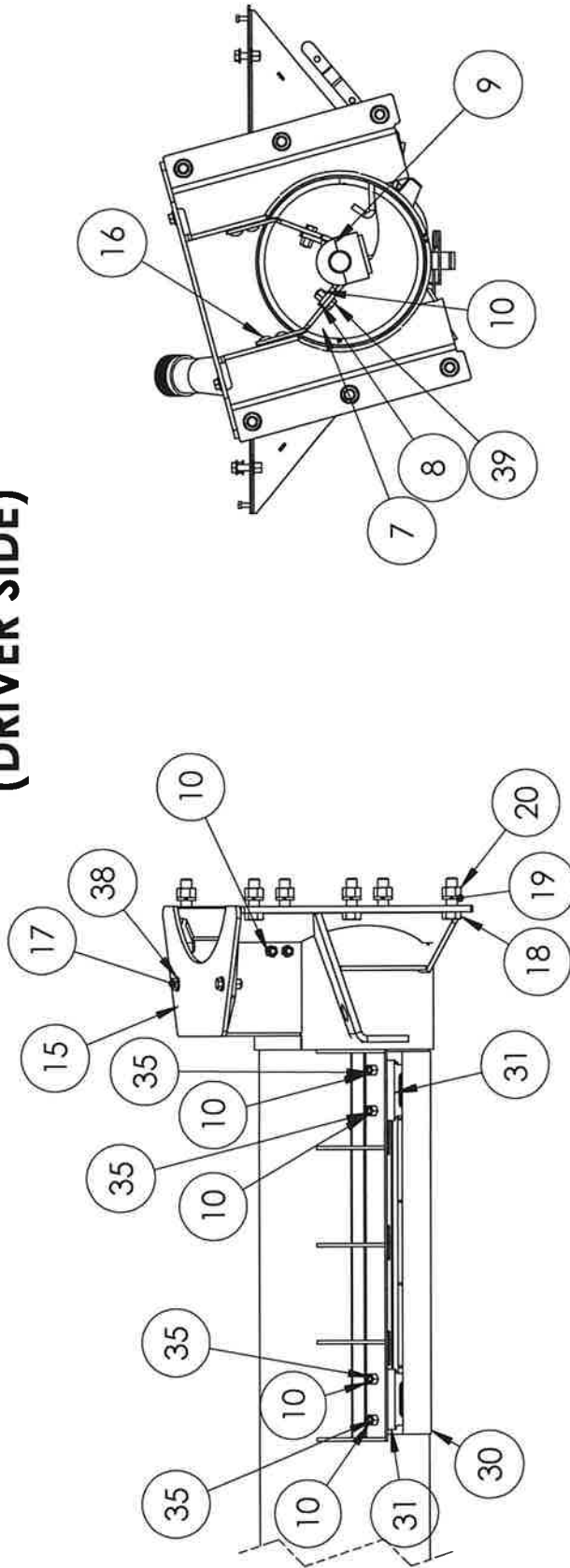

ITEM NO.	PART NUMBER	DESCRIPTION	QTY.
7	47076402	SUPPORT HANGER BEARING	1
8	76401	STRAP RETAINER	1
9	RHB203631	WOOD BEARING	1
10	18566400	NUT SS NYLOCK 3/8	36
15	76400	PLATE COVER	1
16	18055501	BOLT CARRIAGE SS 3/8-16 X 1 1/4" LG	4
17	18026824	BOLT HX SS 3/8 X 1 1/4	26
18	18997930	BOLT HX SS 5/8 X 2	6
19	18971600	WASHER LOCK 5/8 SS	6
20	18477500	NUT 5/8 SS	6
30	47076359	WLDT, CLEAN OUT DOOR	1
31	47076343	WLDT, HINGE	2
35	18996818	BOLT HX SS 3/8 X 3/4 NC	4
38	18991200	WASHER FLAT 3/8 SS	50
39	18026822	BOLT, HEX HD 3/8 X 1 NC SS	2

MT900 LOWER AUGER REAR DETAIL (PASSENGER SIDE)

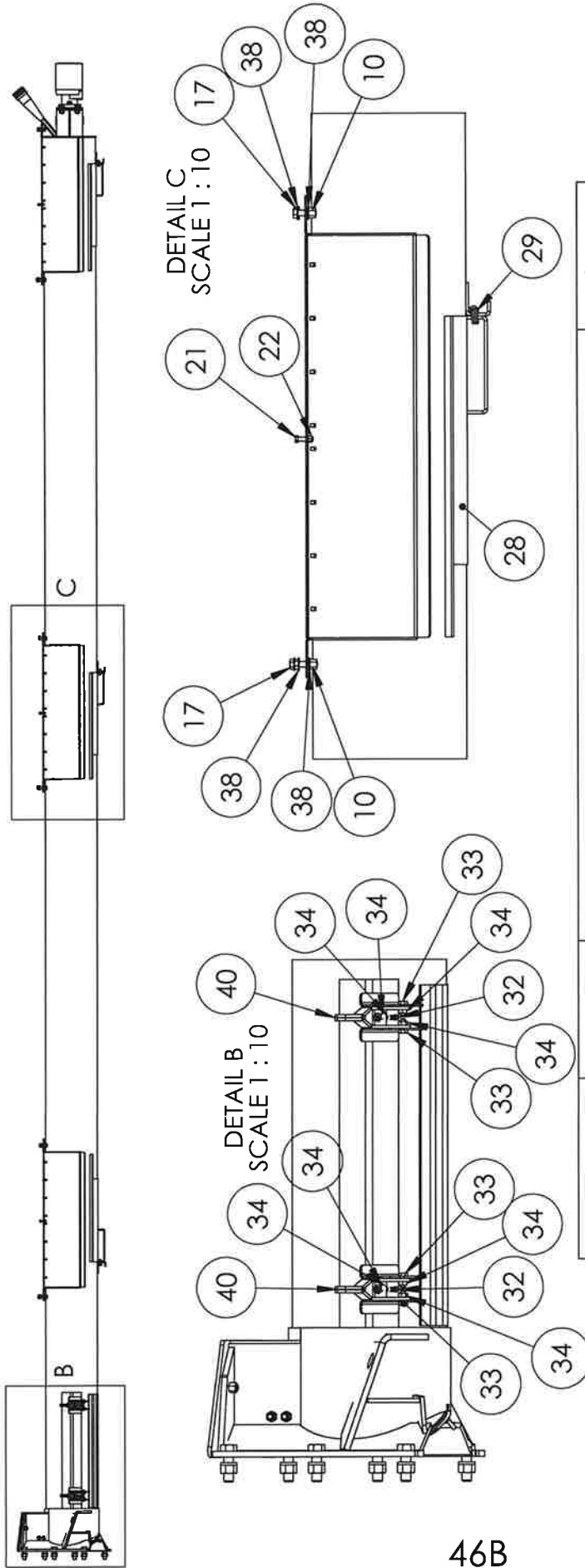

ITEM NO.	PART NO.	DESCRIPTION	QTY.
10	18566400	NUT SS NYLOCK 3/8	36
17	18026824	BOLT HX SS 3/8 X 1 1/4	26
21	18025720	BOLT CAP SS 1/4 X 1	6
22	18569200	NUT 1/4 NYLOCK SS	6
28	47076663	SLIDING DOOR	3
29	18000099	5/16 X 1 3/4 DBL WIRE RND	3
32	76551	HOLD DOWN ROD	2
33	18026418	BOLT CAP SS 5/16 X 3/4	4
34	18476351	NUT HX SS 5/16 SELF LOCK	8
38	18991200	WASHER FLAT 3/8 SS	50
40	47076736	DUMP DOOR LATCH	2

MT600TA TENDER BODY AND FRAME ILLUSTRATION

ALSO INCLUDED BUT NOT SHOWN
PTO CONTROL STAND P/N: 47076712

DETAIL A
SCALE 1 : 10

DETAIL B
SCALE 1 : 2

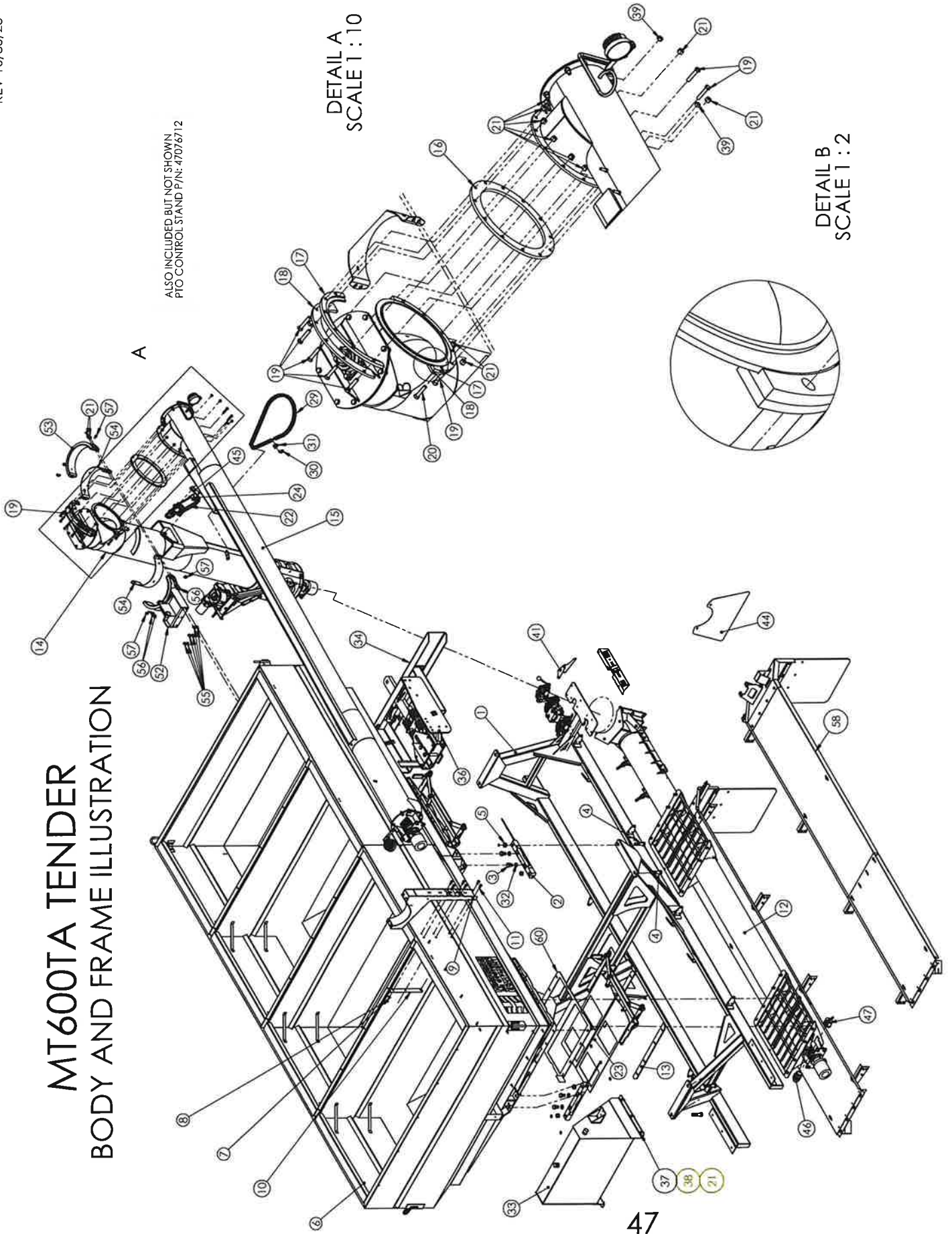

MT600TA BODY AND FRAME PARTS LIST

ITEM	PART NUMBER	DESCRIPTION	QTY.
1	47076560	MT600 FRAME WELDMENT	1
2	SEE NOTE 1	SCALE PACKAGE	4
3	18059303M	BOLT HX CAP 24(3.0) X 70 (MAGNI 565)	8
4	18058501M	BOLT HX CAP G5NCZC 7/8 X 4 (MAGNI)	8
5	18458000M	NUT CTR LOCK 7/8 NC ZC (MAGNI 565)	8
6	47076559	16 TON TENDER BOX	1
7	18991400	WASHER LOCK 1/2 SS	7
8	18997400	NUT 1/2 SS	7
9	47076360	AUGER CRADLE WLDMT	1
10	76373	MOUNTING ANGLE #1	2
11	18475240	BOLT HX CAP 1/2-13 X 1 1/4 LG SS	7
12	SEE PAGES 51-52	LOWER AUGER	1
13	76440	HOPPER SPACER	4
14	SEE PAGES 55-56	VERTICAL AUGER w/ TRANSITION BOOT	1
15	SEE PAGES 57-58	UNLOAD AUGER ASSY	1
16	76322	UNLOAD BEARING	1
17	76338	UNLOAD BEARING, NYLON	2
18	76339	HOUSING, FLANGE	2
19	18027436	BOLT SS CAP 1/2 X 2 1/2	10
20	18477432	BOLT SS CAP 1/2 X 2 1/4	2
21	18567400	NUT SS NYLOCK 1/2	26
22	47005491	3 X 14 CYLINDER	1
23	SEE PAGES 59-60	SLIDING DOOR	2
24	1012830	COUNTER BALANCE LOCK	1
25	47076295	WLDT, AUGER SUPPORT	2
26	18098500M	BOLT HX 3/4 X 1 3/4 G8 NC ZC (MAGNI)	2
27	18098462M	BOLT HX 3/4 X 6 NF B7 FULL (MAGNI)	2
28	18418400M	NUT HX 3/4 NF ZP G5 (MAGNI 565)	8
29	30180	#80 ROLLER CHAIN 62" LENGTH	5.5
30	30080	HALF LINK	1
31	30280	#80 CHAIN CONNECTOR LINK	1
32	18892100M	WASHER LOCK M24 ZC (MAGNI 565)	8
33	47076641	MT900/MT600 OIL TANK 57 GAL	1
34	40057001 (OPTIONAL)	AG7 HD BUMPER	1
35	47076665	SHIELD	2
36	76647 (OPTIONAL)	DROP PLATE	2
37	18022026	BOLT SS HX 1/2 X 1 1/2	6
38	18824800	WASHER FLAT 1/2 SS	12
39	18577400	NUT 1/2 NC SS JAM	2
40	1132237	SINGLE SPOOL VALVE	1
41	76720	REAR LIGHT BRACKET	1
42	76718	NAME PLATE	1
43	1131625	DUAL SPOOL VALVE	1
44	76684	BIB	1
45	76667	PRESSURE RELIEF MOUNT	1
46	200208	2" COUPLER 90 DEG ELBOW	1
47	200172	2" FEMALE COUPLER CAP	1
48	18025718	BOLT CAP SS 1/4 X 3/4	4
49	18569200	NUT 1/4 NYLOCK SS	4
50	18881001	WASHER FLAT 1/4 SS	4
51	m1600decals		1
52	47076324	WLDT, AUGER SUPPORT	1
53	76326	WELDT, VERT AUG. SUPPORT, OUTER	1
54	76478	GLIDE PLATE	2
55	18027416	BOLT CAP SS 1/2 X 1	6
56	18470175	BOLT SS CAP 1/2 X 1 3/4	4
57	200781	1/8 STREET ELBOW SS	4
58	71665	MT600 FENDER KIT COMPLETE	1
59	1191269	SINGLE SPOOL VALVE, CLOSED	1
60	71939	HOPPER GATE SHIM	2

NOTE 1: IF SCALE PACKAGE IS REQUIRED USE P/N:48006000 QTY 1 (INCLUDES CELLS, CONTROLS, AND WIRING)
(SEE PGS. 49-50)
IF SCALE PACKAGE IS NOT REQUIRED USE P/N: 76483 QTY 4

OIL TANK ONLY IS P/N:**47076641** / OIL TANK WITH FITTING IS P/N: 47976641 (SEE PG. 77-78), AND USES ITEMS 37-38 & QTY 6 OF ITEM 21 (18567400)

47076957 - REAR HOPPER AUGER CRADLE SUB ASSEMBLY INCLUDES ITEMS 52 THRU 57 & QTY 10 OF ITEM 21(18567400)

MT600 DRIVER SIDE DETAIL

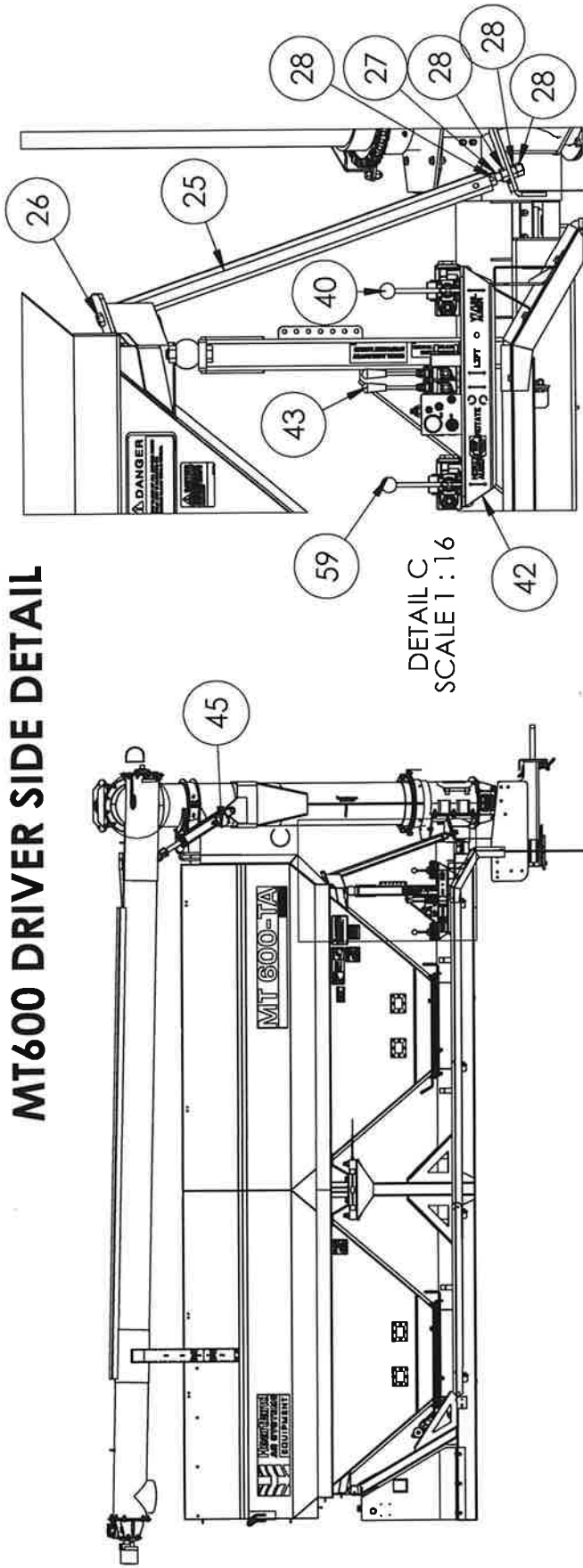

DETAIL D
SCALE 1:12

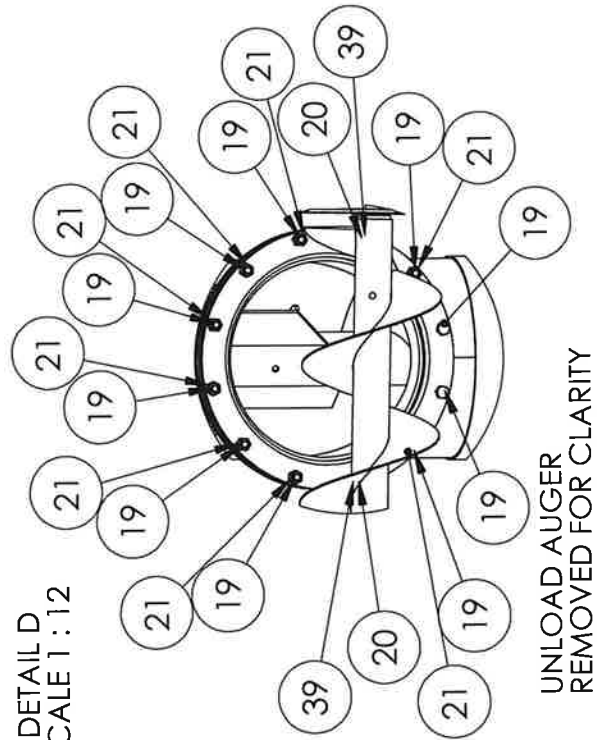

ITEM NO.	PART NO.	DESCRIPTION	QTY.
19	18027436	BOLT SS CAP 1/2 X 2 1/2	10
20	18477432	BOLT SS CAP 1/2 X 2 1/4	2
21	18567400	NUT SS NYLOCK 1/2	26
25	47076295	WLDT, AUGER SUPPORT	2
26	18098500M	BOLT HX 3/4 X 1 3/4 G8 NC ZC (MAGNI)	2
27	18098462M	BOLT HX 3/4 X 6 NF B7 FULL (MAGNI)	2
28	18418400M	NUT HX 3/4 NF ZP G5 (MAGNI 565)	8
39	18577400	NUT 1/2 NC SS JAM	2
40	1132237	SINGLE SPOOL VALVE	1
42	76718	NAME PLATE	1
43	1131625	DUAL SPOOL VALVE	1
45	76667	PRESSURE RELIEF MOUNT	1
59	1191269	SINGLE SPOOL VALVE, CLOSED	1

MT600 PASSENGER SIDE DETAIL

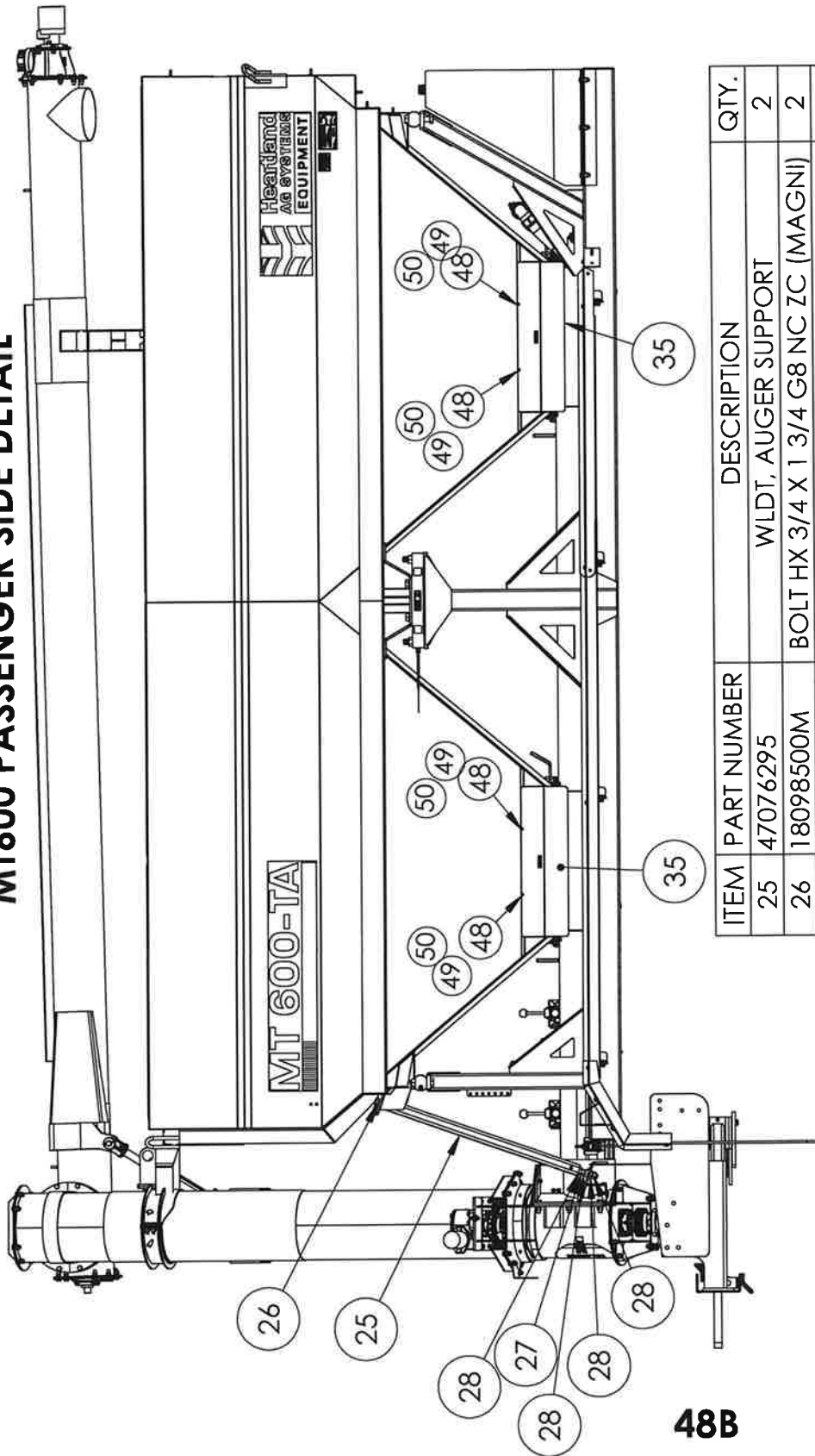

ITEM	PART NUMBER	DESCRIPTION	QTY.
25	47076295	WLDT, AUGER SUPPORT	2
26	18098500M	BOLT HX 3/4 X 1 3/4 G8 NC ZC (MAGNI)	2
27	18098462M	BOLT HX 3/4 X 6 NF B7 FULL (MAGNI)	2
28	18418400M	NUT HX 3/4 NF ZP G5 (MAGNI 565)	8
35	47076665	SHIELD	2
48	18025718	BOLT CAP SS 1/4 X 3/4	4
49	18569200	NUT 1/4 NYLOCK SS	4
50	18881001	WASHER FLAT 1/4 SS	4
58	71665	MT600 FENDER KIT COMPLETE	1

48B

MT600 FENDER KIT

P/N: 71665

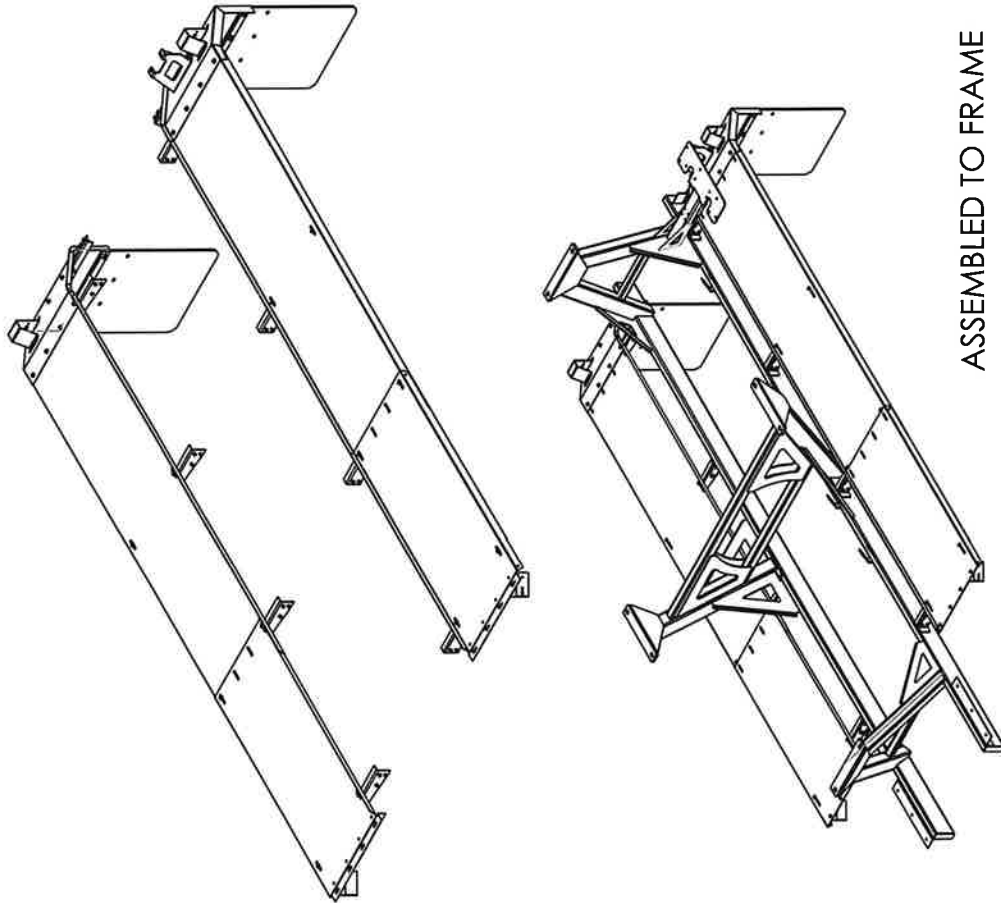

ASSEMBLED TO FRAME

ITEM NO.	PART NUMBER	DESCRIPTION	QTY.
1	71213	FENDER MOUNT	4
2	18026822	BOLT, HEX HD 3/8 X 1 NC SS	28
3	18566400	NUT SS NYLOCK 3/8	64
4	18991200	WASHER FLAT 3/8 SS	100
5	71216	REAR LEG	1
6	71214	FENDER MOUNT	4
7	71217	REAR LEG	1
8	47076632	QUARTER PANEL LH	1
9	28815	FENDER, LH	1
10	47076642	LEFT SHORT FENDER	1
11	76721	LIGHT BRKT REAR	2
12	28163	LIGHT BRKT FRONT LH	1
13	76714	MUD FLAP	2
14	47006302	MOUNTING STRAP	2
15	28816	FENDER RH	1
16	47076631	QUARTER PANEL RH	1
17	47076643	LEFT SHORT FENDER	1
18	28164	LIGHT BRKT FRONT, RH	1
19	18991100	WASHER, FLAT 5/16 SS	16
20	18457500	NUT 5/16-18 NYLOCK	8
21	18026422	BOLT CAP SS 5/16 X 1	8
22	18026824	BOLT HX SS 3/8 X 1 1/4	28
23	18056826	BOLT HX NC ZC 3/8 X 1 1/2	8
24	71794	FENDER SUPPORT BRACKET WELDT	1

MT600 FENDER KIT

P/N: 71665

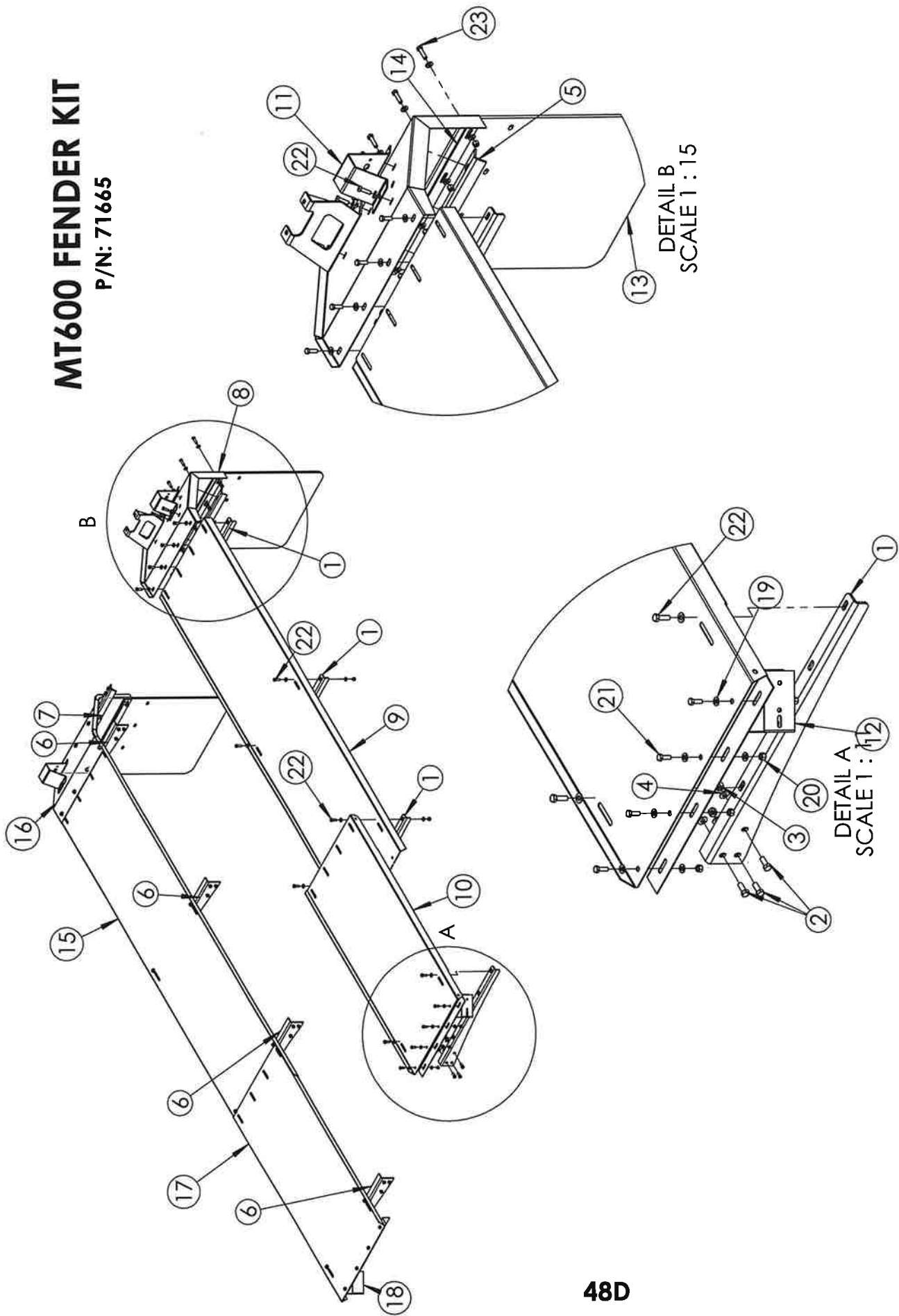

MT600 SCALE PACKAGE

PART #:48006000

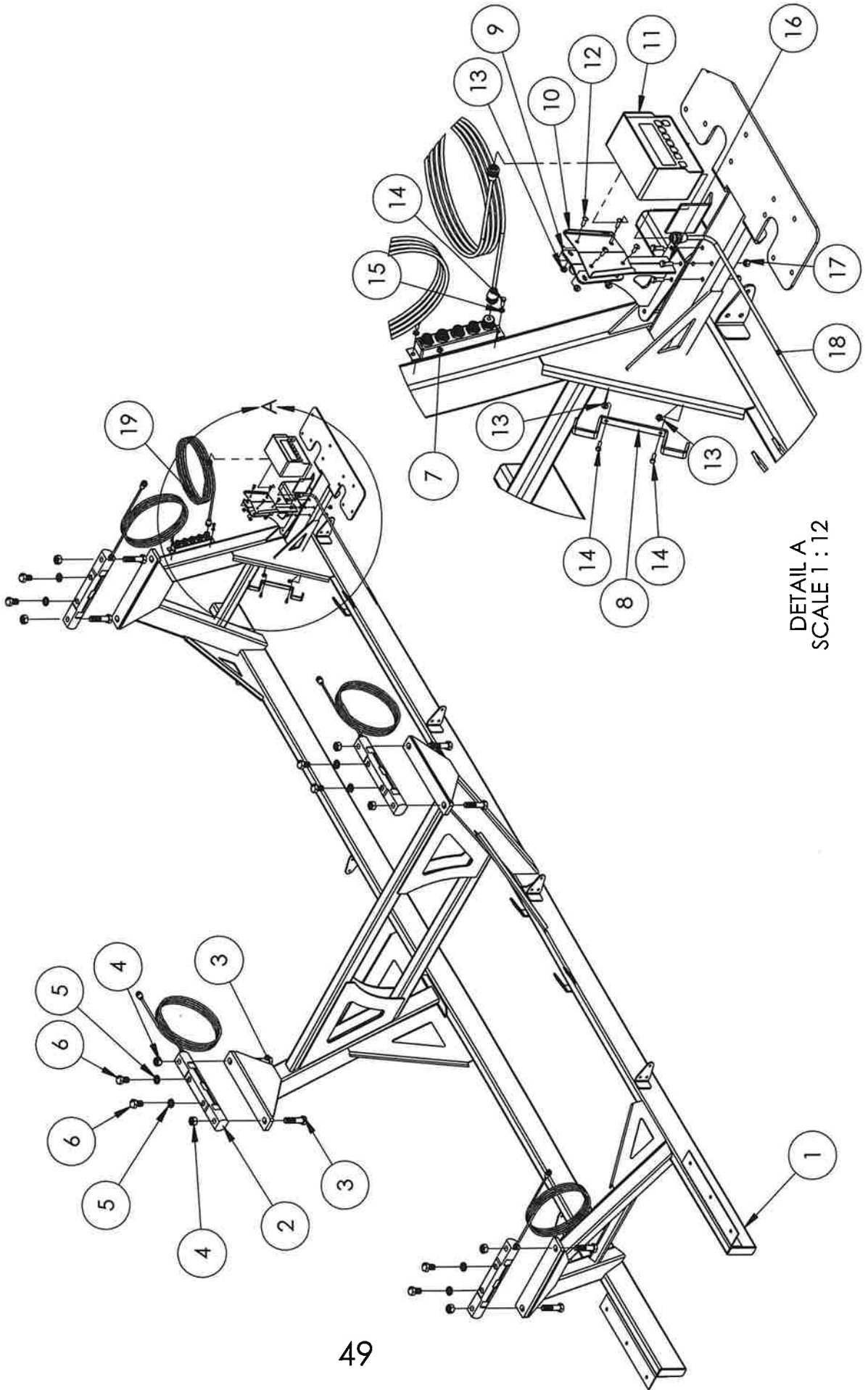

DETAIL A
SCALE 1 : 12

MT600 SCALE PACKAGE

PART #:48006000

ITEM NO.	PART NUMBER	DESCRIPTION	QTY.
1	47076560	MT600 FRAME WELDMENT	1
2	AWT27-500205	WEIGH BAR, DOUBLE END FLAT W/ 30 FT CABLE 5 PIN AWT CONN.	4
3	18058501M	BOLT HX CAP G5NCZC 7/8 X 4 (MAGNI)	8
4	18458000M	NUT CTR LOCK 7/8 NC ZC (MAGNI 565)	8
5	18892100M	WASHER LOCK M24 ZC (MAGNI 565)	8
6	18059303M	BOLT HX CAP 24(3.0) X 70 (MAGNI 565)	8
7	19219-0015	4 BAR J-BOX W/5 PIN AWT CONNECTORS	1
8	47009766	BRACKET, LOAD CELL CABLES	1
9	47076730	SCALE STAND	1
10	76597	SCALE HEAD PLATE	1
11	640MS5P-640M	INDICATOR 5 PIN AWT CONNECTOR	1
12	18706423	SCREW, SLOTTED TRUSS HEAD 1/4 X 3/4 SS	4
13	18971400	NUT SER FLG SS 1/4	6
14	18025718	BOLT CAP SS 1/4 X 3/4	4
15	18991000	WASHER LOCK 1/4 SS	2
16	18026422	BOLT CAP SS 5/16 X 1	4
17	18457500	NUT 5/16-18 NYLOCK	4
18	19266-0058	18FT POWER CORD AWT W/ TINNED LEADS	1
19	28755-0032	25FT INTERFACE CABLE WITH 5 PIN CONNECTORS EACH END	1

NOTE:

1. ITEMS 1,3,4,5, AND 6 ARE NOT INCLUDED IN THE PACKAGE
2. ALSO REQUIRED (BUT NOT SHOWN), ARE QTY. 35 OF P/N #21245 - CABLE TIE MOUNTING BASE (BLACK)

ELECTRICAL POWER SUPPLY:

- FOR TRUCK MOUNTED UNITS HOOK TO TRUCK BATTERY
- FOR TRAILER MOUNTED TENDER W/ KUBOTA ENGINE PACKAGE, HOOK TO KUBOTA'S BATTERY
- **(OPTIONAL)** FOR FELLING TRAILERS HOOK DIRECTLY TO STUDDED JUNCTION BOX **P/N: AC2831**, LOCATED IN FRONT OF THE REAR AXLE

(FOR SCALE PACKAGE WHITE WIRES ARE POWER/ BLACK WIRES ARE GROUND)

CONFIGURE CALIBRATION NUMBER FOR MODEL 640 INDICATOR

(Information supplied by Avery Weigh-Tronix)

Procedure to configure calibration number in a 640 Series Indicator:

1. Press and hold the **HOLD/MENU** button for 3 beeps and release
2. *SET.PAS* will appear on the display
 - a. Use the **RM** and **M+** buttons to enter in the password 640 (To advance to next character press the **HOLD/MENU** button)
3. Once 640 is displayed on the display press the **PRINT SELECT** button
4. 640 will appear on the display with all annunciators one around the display
5. Press the **PRINT SELECT** button
6. *CONFIG* will appear on the display
7. Press the **PRINT SELECT** button
 - a. Use the **RM** and **M+** buttons to enter in the Config Code 98300 (To advance to next character press the **HOLD/MENU** button)
8. Once 98300 is displayed on the display press the **PRINT SELECT** button
9. *CONFIG* will appear on the display
10. Press the **HOLD/MENU** button once
11. *CUSTOM* will appear on the display
12. Press the **PRINT SELECT** button
13. Use the **RM** and **M+** buttons to enter one of the following codes (To advance to next character press the **HOLD/MENU** button)
 - a. 4 Bar System using part number AWT27-500229 (Spreaders and 6500 Applicators)
 - i. Custom Code number is 32000
 - b. 4 Bar System using part number AWT27-500205 (MT600 Tender)
 - i. Custom Code number is 36904
 - c. 6 Bar System using part number AWT27-500205 (MT900 Tender)
 - i. Custom Code number is 55356
14. Once the correct code number is displayed press the **PRINT SELECT** button once
15. *CUSTOM* will appear on the screen
16. Press the **G/N** button until display says *BUSY*
17. Your configuration is complete

It seems like a lot of steps, but this process should take less than one minute.

(For further inquiries/details, please consult your Avery Weigh-Tronix manual.)

MT600 LOWER AUGER TUBE ILLUSTRATION

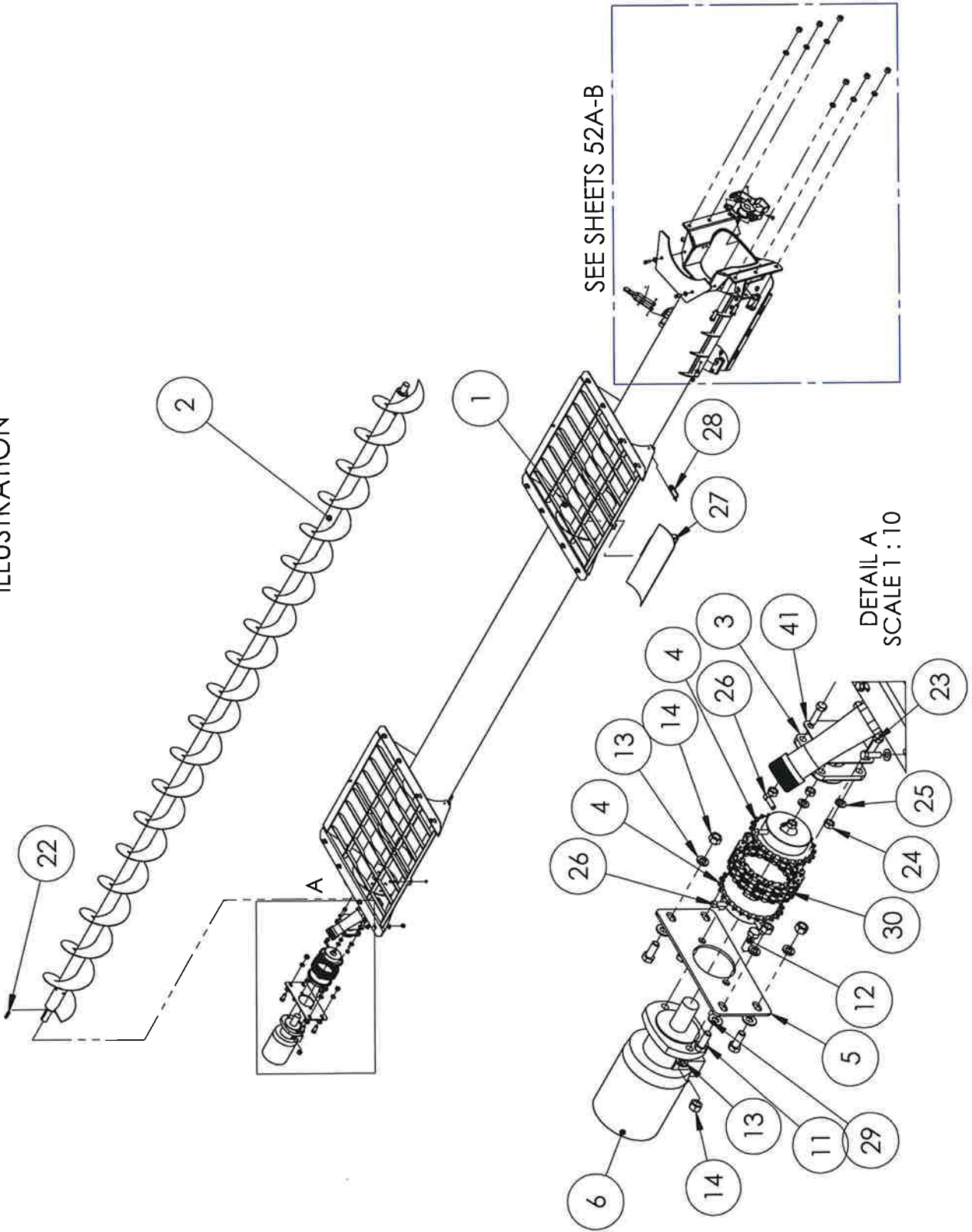

MT600 LOWER AUGER TUBE

PART LIST

LATWTBLST
REV 10/30/23

ITEM NO.	PART NUMBER	DESCRIPTION	QTY.
1	47076558	16 TON AUGER	1
2	47076557	AUGER FLIGHTING WELDMENT	1
3	10649	4-BOLT FLANGE BEARING, 1.25" SHAFT	1
4	48300151	24 TOOTH SPROCKET #50 CHAIN 1 1/4" BORE 5/16 KEY	2
5	76444	PLATE MOTOR	1
6	1040020	MOTOR HYDRAULIC (LOWER AUGER)	1
7	47076402	SUPPORT HANGER BEARING	1
8	76401	STRAP RETAINER	1
9	RHB203631	WOOD BEARING	1
10	18566400	NUT SS NYLOCK 3/8	28
11	18475240	BOLT HX CAP 1/2-13 X 1 1/4 LG SS	4
12	18022026	BOLT SS HX 1/2 X 1 1/2	2
13	18991400	WASHER LOCK 1/2 SS	6
14	18997400	NUT 1/2 SS	6
15	76400	PLATE COVER	1
16	18026824	BOLT HX SS 3/8 X 1 1/4	18
17	18997930	BOLT HX SS 5/8 X 2	6
18	18971600	WASHER LOCK 5/8 SS	6
19	18477500	NUT 5/8 SS	6
20	18025720	BOLT CAP SS 1/4 X 1	4
21	18569200	NUT 1/4 NYLOCK SS	4
22	37265	KEY	1
23	18997650	BOLT HX SS 7/16 X 1 1/2	4
24	18997100	NUT HX SS 7/16 NC	4
25	18991300	WASHER LOCK 7/16 SS	4
26	18767449	SCREW SET 5/16 X 1 SQHD NCSC	4
27	47076663	SLIDING DOOR	2
28	18000099	5/16 X 1 3/4 DBL WIRE RND	2
29	18824800	WASHER, FLAT 1/2 SS	8
30	29941	CHAIN COUPLER	1
31	18991200	WASHER FLAT 3/8 SS	34
32	18026822	BOLT, HEX HD 3/8 X 1 NC SS	2
33	47076359	WLDT, CLEAN OUT DOOR	1
34	47076343	WLDT, HINGE	2
35	76551	HOLD DOWN ROD	2
36	18026418	BOLT CAP SS 5/16 X 3/4	4
37	18476351	NUT HX SS 5/16 SELF LOCK	8
38	18996818	BOLT HX SS 3/8 X 3/4 NC	4
39	47076736	DUMP DOOR LATCH	2
40	18055501	BOLT CARRIAGE SS 3/8-16 X 1 1/4" LG	4
41	71790	BEARING GUARD, 1.25" SHAFT	1

WHEN ORDERING A REPLACEMENT BEARING (ITEM#3), ALSO ORDER GREASE FITTING ADAPTER P/N: 1128526

MT600 LOWER AUGER REAR DETAIL (DRIVER SIDE)

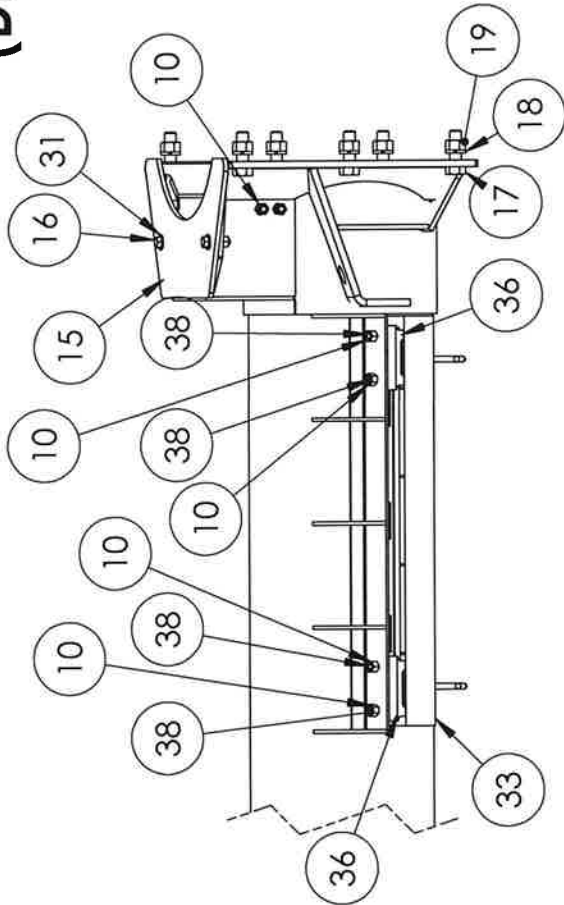
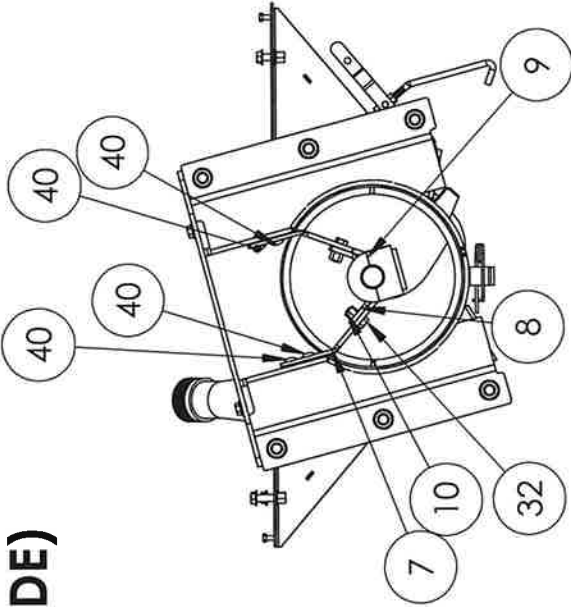

ITEM NO.	PART NUMBER	DESCRIPTION	QTY.
7	47076402	SUPPORT HANGER BEARING	1
8	76401	STRAP RETAINER	1
9	RHB203631	WOOD BEARING	1
10	18566400	NUT SS NYLOCK 3/8	28
15	76400	PLATE COVER	1
16	18026824	BOLT HX SS 3/8 X 1 1/4	18
17	18997930	BOLT HX SS 5/8 X 2	6
18	18971600	WASHER LOCK 5/8 SS	6
19	18477500	NUT 5/8 SS	6
31	18991200	WASHER FLAT 3/8 SS	34
32	18026822	BOLT, HEX HD 3/8 X 1 NC SS	2
33	47076359	WLDT, CLEAN OUT DOOR	1
36	47076343	WLDT, HINGE	2
38	18996818	BOLT HX SS 3/8 X 3/4 NC	4
40	18055501	BOLT CARRIAGE SS 3/8-16 X 1 1/4" LG	4

MT600 LOWER AUGER REAR DETAIL (PASSENGER SIDE)

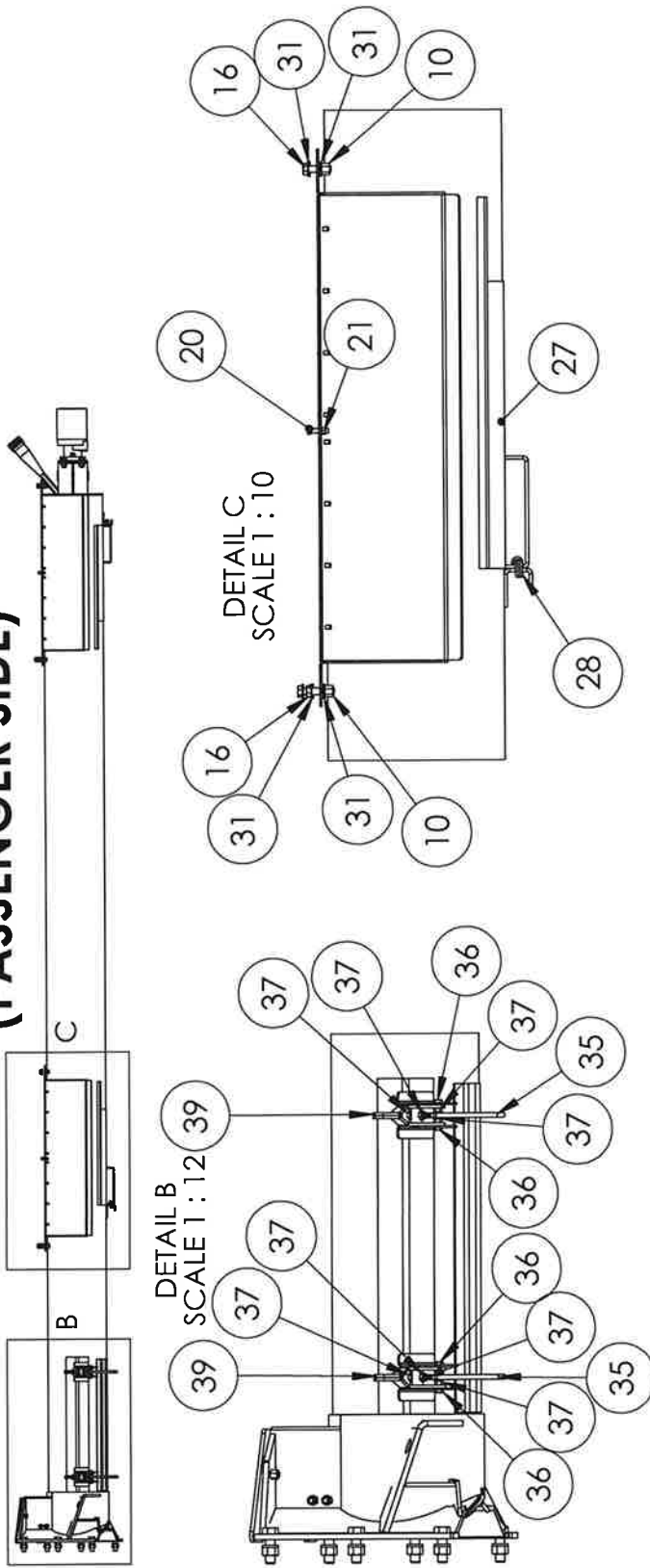

ITEM NO.	PART NUMBER	DESCRIPTION	QTY.
10	18566400	NUT SS NYLOCK 3/8	28
16	18026824	BOLT HX SS 3/8 X 1 1/4	18
20	18025720	BOLT CAP SS 1/4 X 1	4
21	18569200	NUT 1/4 NYLOCK SS	4
27	47076663	SLIDING DOOR	2
28	18000099	5/16 X 1 3/4 DBL WIRE RND	2
31	18991200	WASHER FLAT 3/8 SS	34
35	76551	HOLD DOWN ROD	2
36	18026418	BOLT CAP SS 5/16 X 3/4	4
37	18476351	NUT HX SS 5/16 SELF LOCK	8
39	47076736	DUMP DOOR LATCH	2

TRANSITION BOOT ILLUSTRATION

TBISO
03/19/24

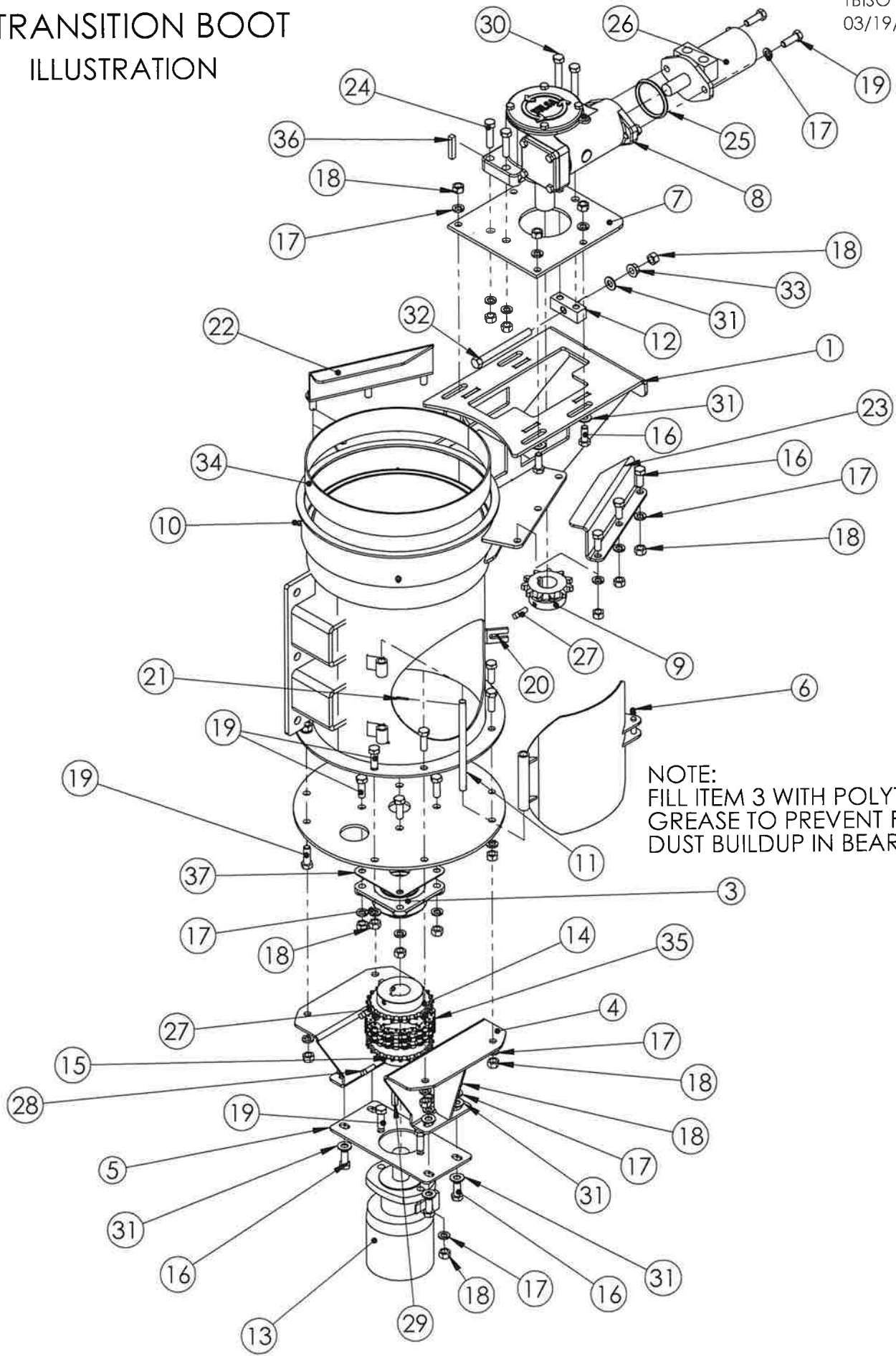

NOTE:
FILL ITEM 3 WITH POLYTECHNIC
GREASE TO PREVENT FERTILIZER
DUST BUILDUP IN BEARING

TRANSITION BOOT PART LIST

TBPL
03/19/24

ITEM NO.	PART NUMBER	DESCRIPTION	QTY.
1	47076420	WLDT, VERT. BOOT	1
2	76258	PLATE AUGER	1
3	52065	BEARING	1
4	47076455	MOTOR MOUNT WLDMT	2
5	76444	PLATE MOTOR	1
6	47076271	WLDT, COVER	1
7	76427	MOTOR MOUNT PLATE	1
8	1087194	GEARBOX TO STAND PLATE	1
9	76306	SPROCKET	1
10	18911805	FITTING, GREASE ZERK 1/4-28 STRAIGHT SS	4
11	76476	HINGE PIN	1
12	76574	ADJUSTMENT BLOCK	1
13	1116558	MOTOR HYDRAULIC (VERTICAL AUGER)	1
14	48300161	SPROCKET #50 24 TOOTH (1.50 BORE W/ 3/8 KEY)	1
15	48300151	24 TOOTH SPROCKET #50 CHAIN 1 1/4" BORE 5/16 KEY	1
16	18475240	BOLT HX CAP 1/2-13 X 1 1/4 LG SS	14
17	18991400	WASHER LOCK 1/2 SS	32
18	18997400	NUT 1/2 SS	31
19	18022026	BOLT SS HX 1/2 X 1 1/2	16
20	18987900	NUT SER FLG SS 3/8	1
21	18660622	PIN COTTER SS 1/8 X 1	2
22	76485	CHAIN GUARD #2	1
23	76484	CHAIN GUARD #1	1
24	18027417	BOLT HX SS NC 1/2 X 2	2
25	1023992	O-RING	1
26	1028801	MOTOR HYDRAULIC (GEAR BOX)	1
27	18766822	SCREW SET 3/8 X 1 SQHD NCSC	4
28	18767449	SCREW SET 5/16 X 1 SQHD NCSC	2
29	37265	KEY	1
30	18027436	BOLT SS CAP 1/2 X 2 1/2	2
31	18824800	WASHER, FLAT 1/2 SS	13
32	01055	TAKE UP BOLT	1
33	18977400	FLANGE NUT, 1/2 NC SS	1
34	76543	PLASTIC LINER	1
35	29941	CHAIN COUPLER	1
36	20982	3/8 SQ KEY X 1 1/2 LG	1
37	71789	BEARING GUARD, 1.5" SHAFT	1

WHEN ORDERING A REPLACEMENT BEARING (ITEM #3),
ALSO ORDER GREASE FITTING ADAPTER P/N: 1128526

VERTICAL AUGER W/ TRANSITION BOOT ILLUSTRATION

VALST
REV 10/30/23

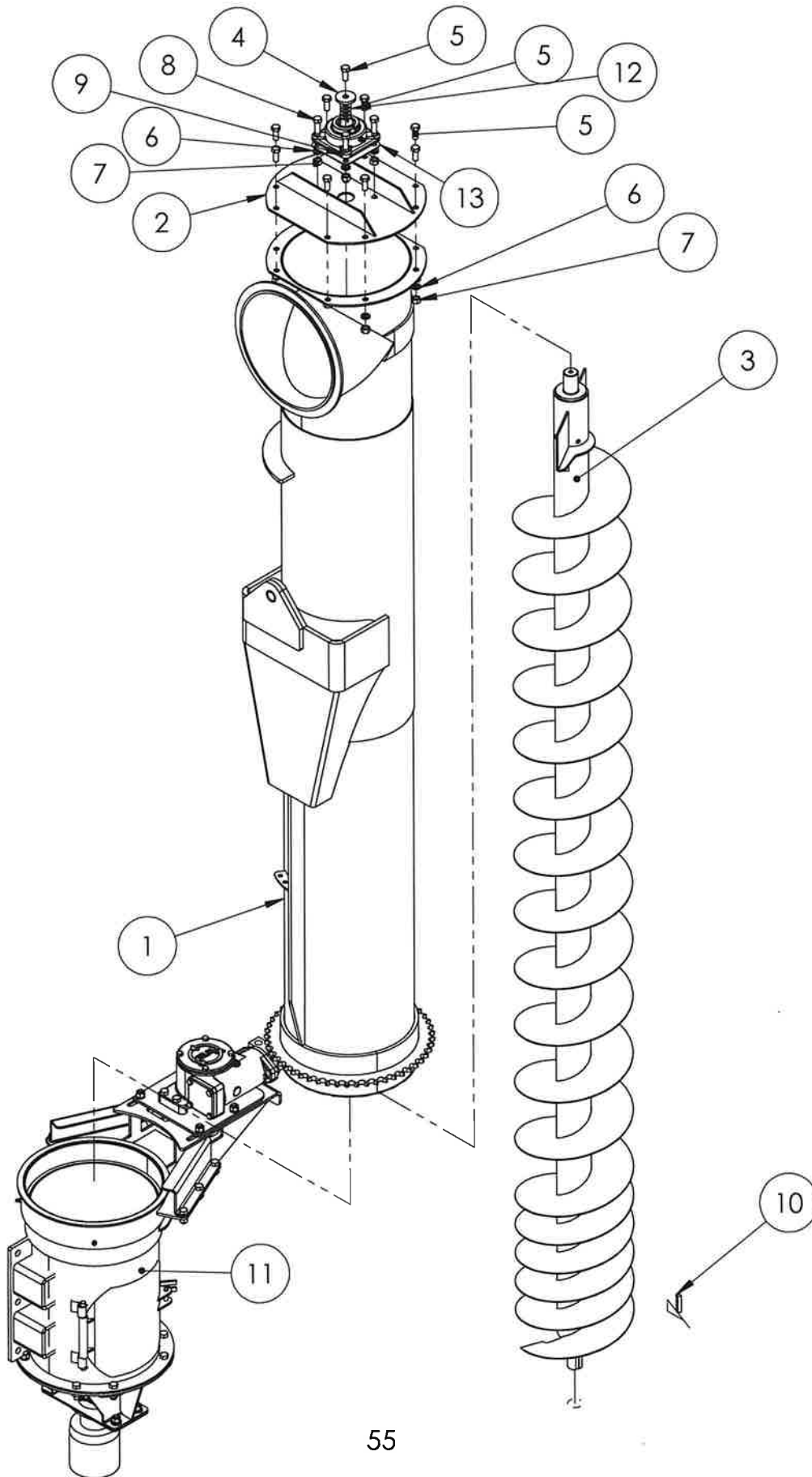

VERTICAL AUGER W/ TRANSITION BOOT PARTS LIST

ITEM NO.	PART NUMBER	DESCRIPTION	QTY.
1	47076209	WLDT, VERT AUGER	1
2	47076225	WLDT, END PLATE	1
3	47076410	AUGER FLIGHTING WELDMENT	1
4	76377	STOP WASHER	1
5	18475240	BOLT HX CAP 1/2-13 X 1 1/4 LG SS	9
6	18991400	WASHER LOCK 1/2 SS	12
7	18997400	NUT 1/2 SS	12
8	18022026	BOLT SS HX 1/2 X 1 1/2	4
9	52065	BEARING	1
10	20982	3/8 SQ KEY X 1 1/2 LG	1
11	SEE PAGES 53-54	TRANSITION BOOT	1
12	18824800	WASHER FLAT 1/2 SS	4
13	71789	BEARING GAURD, 1.5" SHAFT	1

NOTE:

1. ITEM 12 IS USED TO ENSURE PROPER SPACING OF THE AUGER, AND PREVENT IT FROM BEING CINCHED UP SO THAT THE AUGER SHAFT RUBS ON THE END PLATE. THIS ALSO ALLOWS FOR PROPER CLEANOUT OF THE TRANSITION BOOT.

2. WHEN ORDERING A REPLACEMENT BEARING (ITEM#9), ALSO ORDER GREASE FITTING ADAPTER P/N: 1128526

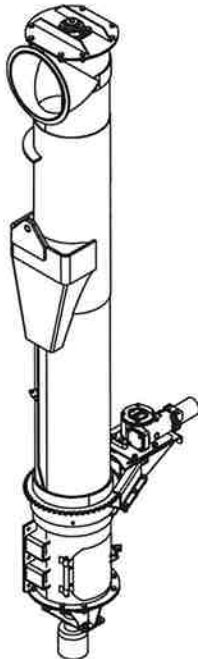

UAISO
10/30/23

UNLOAD AUGER ILLUSTRATION

(AUGER W/O POLY IS P/N: 47076241)

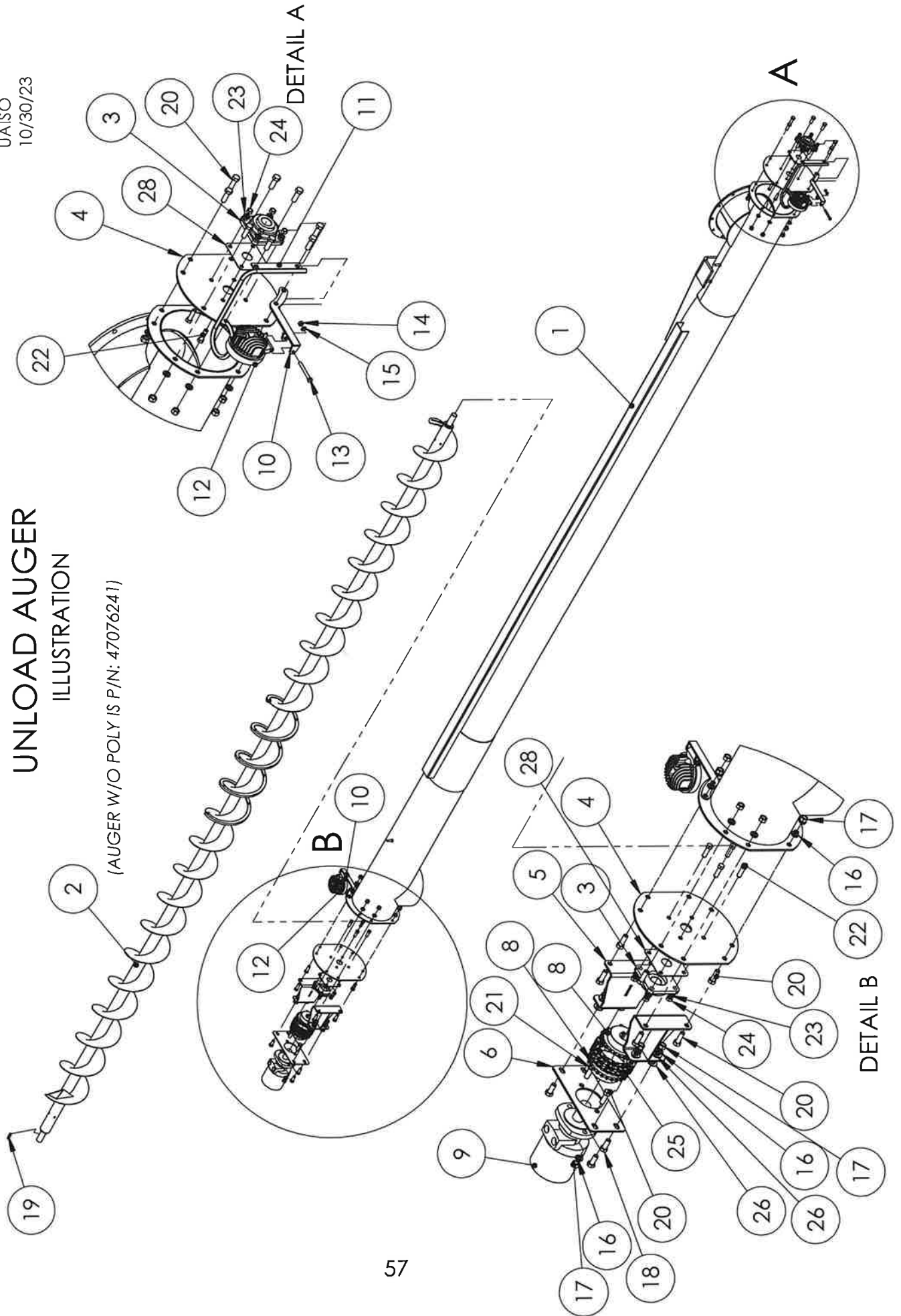

UNLOAD AUGER PARTS LIST

UALIST
REV 10/30/23

ITEM NO.	PART NUMBER	DESCRIPTION	QTY.
1	47076203	WLDT, UNL. AUG. TUBE	1
2	76770	UNLOAD AUGER W/ POLY EDGE	1
3	10649	4-BOLT FLANGE BEARING, 1.25" SHAFT	2
4	76340	PLATE UNL AUGER END	2
5	47076456	MOTOR MOUNT WLDMT	2
6	76444	PLATE MOTOR	1
7	210400084	BUSHING, PIN HOLE	1
8	48300151	24 TOOTH SPROCKET #50 CHAIN 1 1/4" BORE 5/16 KEY	2
9	1040045	MOTOR HYDRAULIC	1
10	47076486	LED MOUNTING BRACKET	2
11	47076512	PIG TAIL BRKT	1
12	QFA199	LED LIGHT	2
13	18996426	BOLT CAP SS 5/16 X 2 3/4	2
14	18476350	NUT HX 5/16 SS	2
15	18891110	WASHER, LOCK 5/16 ZC	2
16	18991400	WASHER LOCK 1/2 SS	22
17	18997400	NUT 1/2 SS	22
18	18475240	BOLT HX CAP 1/2-13 X 1 1/4 LG SS	4
19	37265	KEY	1
20	18022026	BOLT SS HX 1/2 X 1 1/2	18
21	18767449	SCREW SET 5/16 X 1 SQHD NCSC	4
22	18997650	BOLT HX SS 7/16 X 1 1/2	8
23	18991300	WASHER LOCK 7/16 SS	8
24	18997100	NUT HX SS 7/16 NC	8
25	29941	CHAIN COUPLER	1
26	18824800	WASHER, FLAT 1/2 SS	8
27	18026824	BOLT HX SS 3/8 X 1 1/4	1
28	71790	BEARING GUARD, 1.25" SHAFT	2

WHEN ORDERING A REPLACEMENT BEARING (ITEM#3),
ALSO ORDER GREASE FITTING ADAPTER P/N: 1128526

(ALSO AVAILABLE P/N: 310 -- 3' OF 10" FLEX HOSE W/ SS CLAMP)

LIGHTING KIT P/N: 47000199 INCLUDES ITEMS 10,12 AND 14 AND WIRING HARNESS
W/ SWITCH P/N: QWH759

SLIDING DOOR ASSEMBLY PARTS LIST

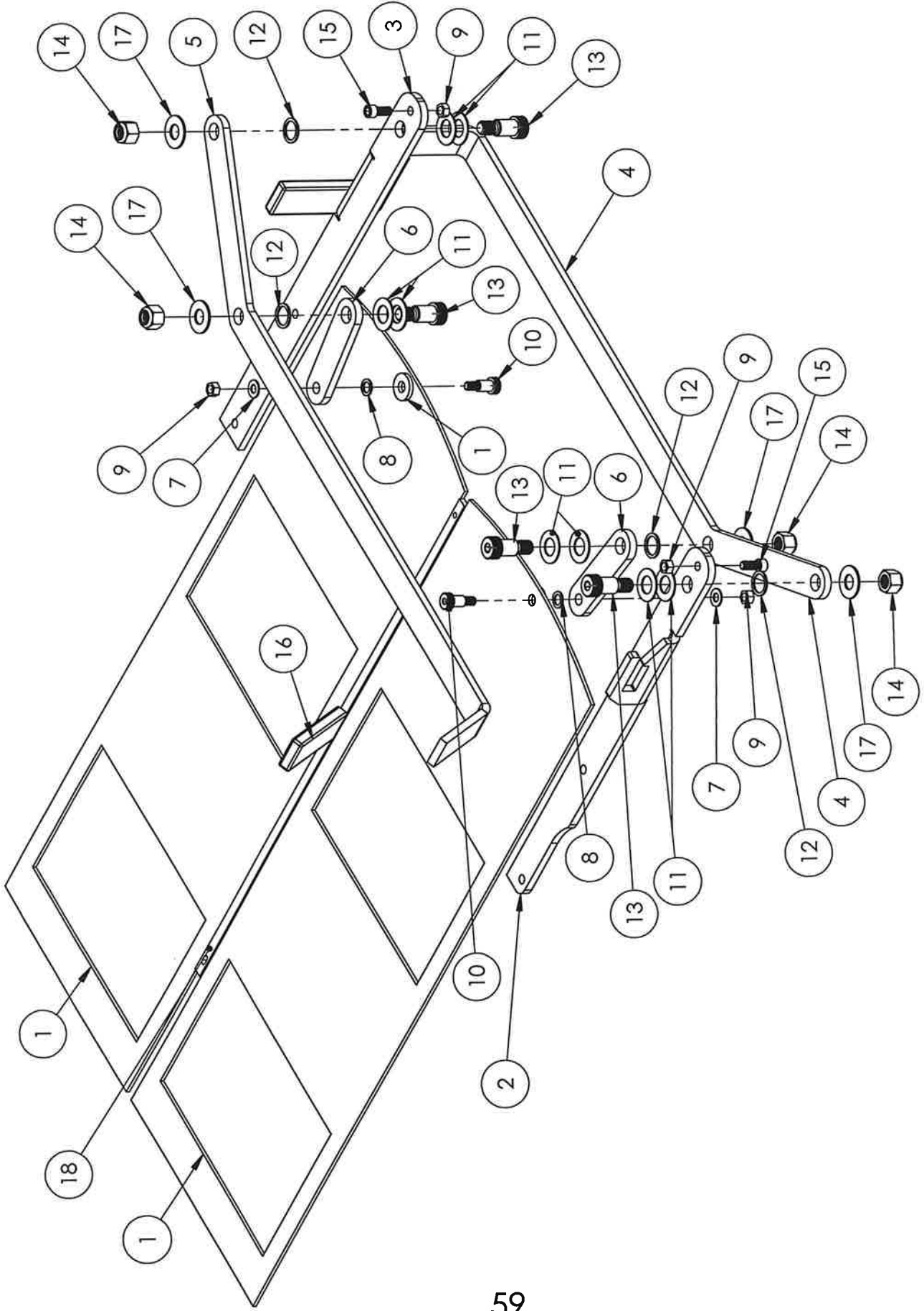

SLIDING DOOR ASSEMBLY PARTS LIST

ITEM NO.	PART NUMBER	DESCRIPTION	QTY.
1	47076536	DOOR WELDMENT	2
2	76762	LINKAGE SUPPORT LH	1
3	76763	LINKAGE SUPPORT RH	1
4	76760	HANDLE RH	1
5	76764	HANDLE LH	1
6	76761	LINKAGE	2
7	18991200	WASHER FLAT 3/8 SS	2
8	18984800	WASHER NYLON 1/2	2
9	18566400	NUT SS NYLOCK 3/8	4
10	18059302	SHOULDER BOLT 1/2 X 3/4 SS	2
11	18971800	WASHER FLAT 3/4 SS	8
12	18861800	WASHER NYLON 3/4	4
13	18051619	SHOULDER BOLT 3/4 X 1	4
14	18487600	NUT, LOCK 5/8-11 SS	4
15	18776822	SHCS 3/8-16 X 1 LG SS	2
16	54143A	HANDLE COVER	2
17	18981600	WASHER FLAT 5/8 SS	4
18	3670	DOOR GUIDE	1

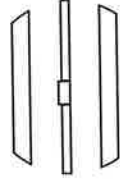
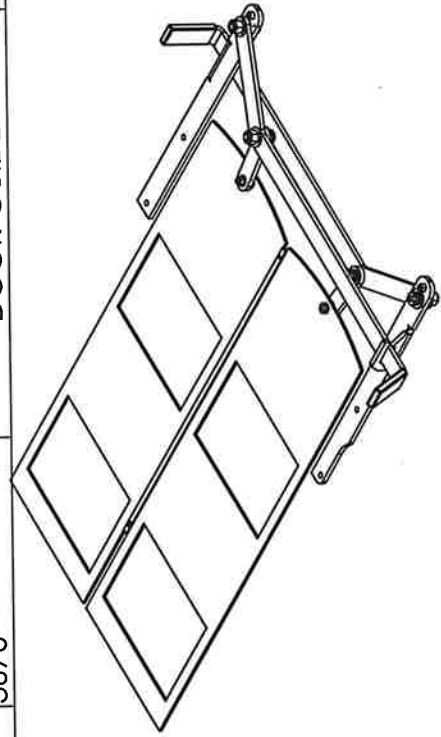
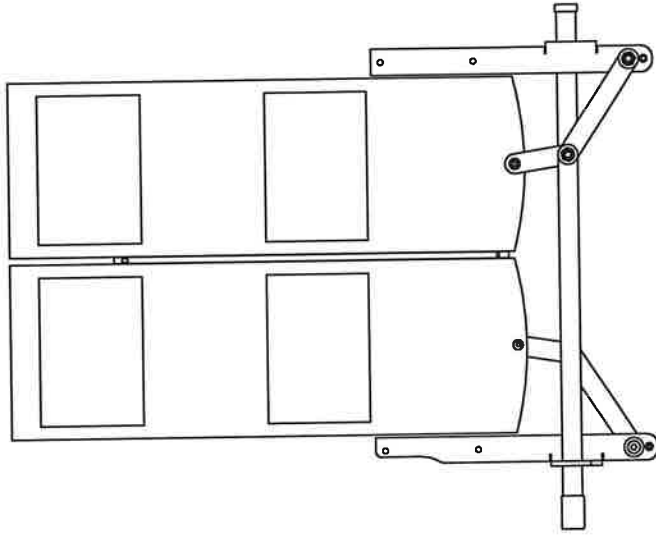

DETAIL A
SCALE 1:4

TRAILER MOUNT LADDER PART ILLUSTRATION

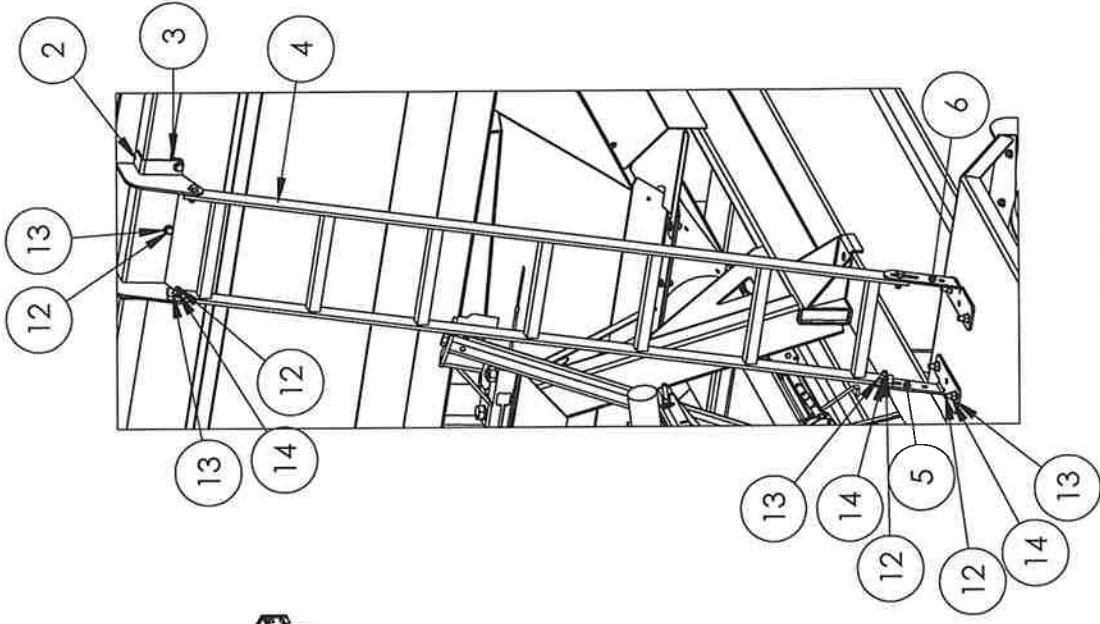

DETAIL B
SCALE 1 : 20
BOLTS FOR TRAILER MOUNT
ON THE REAR LADDER COME UP
FROM THE BASE

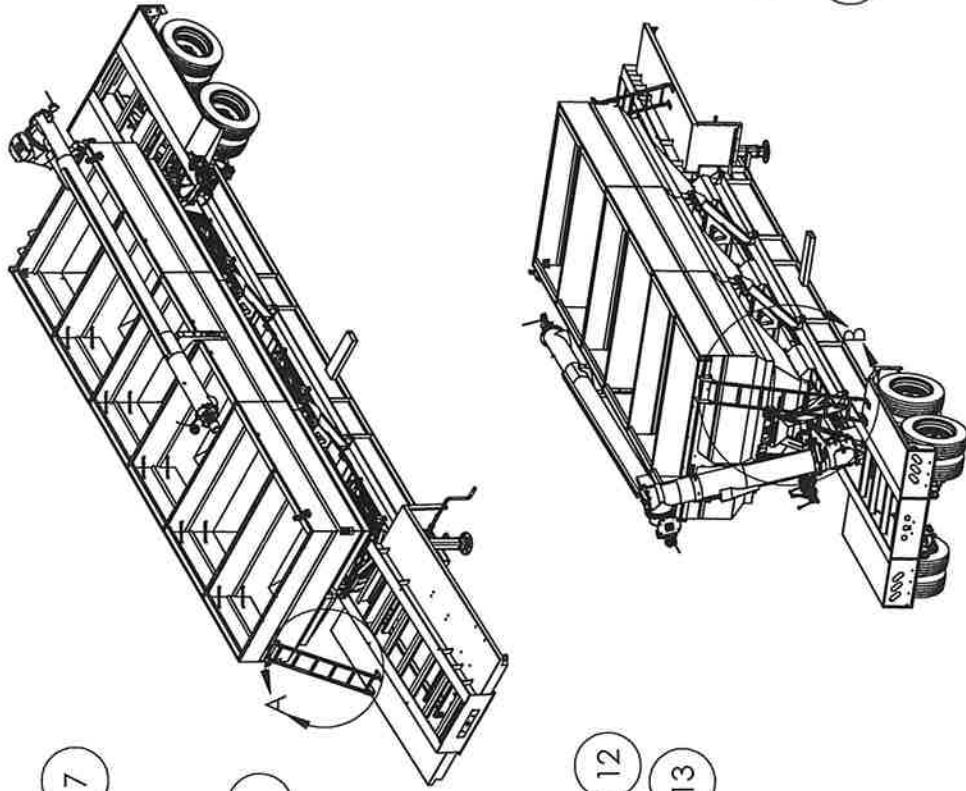

NOTE:
LADDER MUST FLOAT FREELY WHEN ASSEMBLED,
TO PREVENT DAMAGE FROM TRAILER MOVING

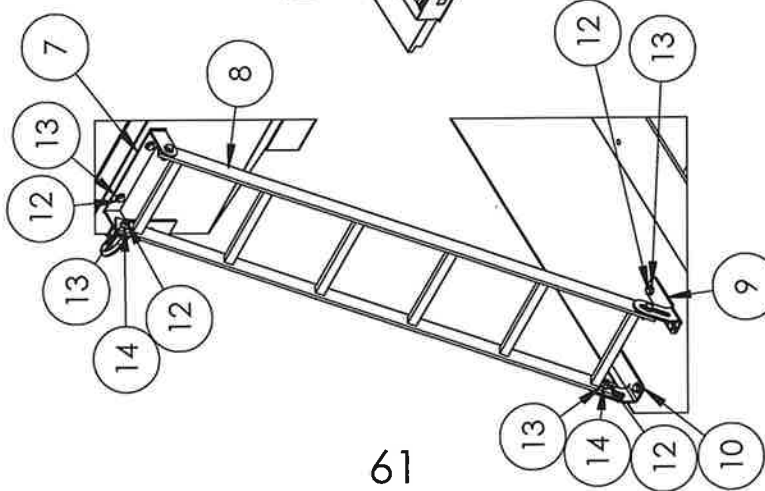

DETAIL A
SCALE 1 : 20

TRAILER MOUNT LADDER PART LISTING AND LOCATION

ITEM NO.	PART NUMBER	DESCRIPTION	QTY.
1	TENDER TRAILER	MT900TA MOUNTED ON TRAILER	1
2	47076505	LADDER BRACKET	1
3	76508	CLAMP PLATE	1
4	47076500	LADDER	1
5	76503	MOUNTING BRACKET #1	1
6	76504	MOUNTING BRACKET #2	1
7	47076513	FRONT LADDER MTG BRKT	1
8	47076514	FRONT LADDER	1
9	76519	MOUNTING BRACKET #1	1
10	76520	MOUNTING BRACKET #2	1
11	47076699	LOWER LADDER	1
12	18022026	BOLT SS HX 1/2 X 1 1/2	21
13	18824800	WASHER FLAT 1/2 SS	42
14	18567400	NUT SS NYLOCK 1/2	21
15	18056824	BOLT HX CAP G5 NC ZC 3/8 X 1 1/4	3
16	18991200	WASHER FLAT 3/8 SS	6
17	18459200	NUT 3/8 NYLOCK	3
18	4003260	TARP STOP (SUPPLIED W/ ROLL TARP)	2

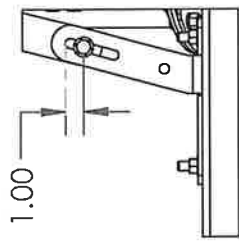

DETAIL E
SCALE 1 : 10
TYPICAL
FRONT & REAR
MOUNTS

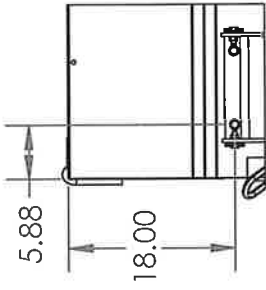

DETAIL C
SCALE 1 : 20

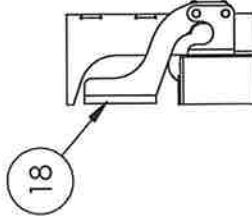

DETAIL D
SCALE 1 : 10

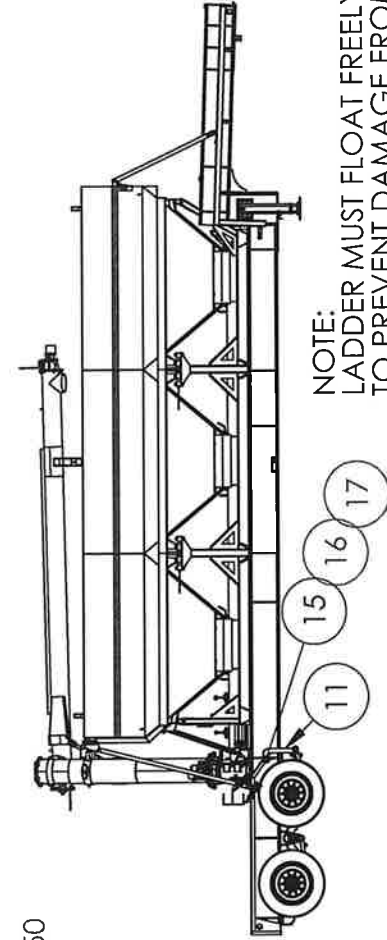
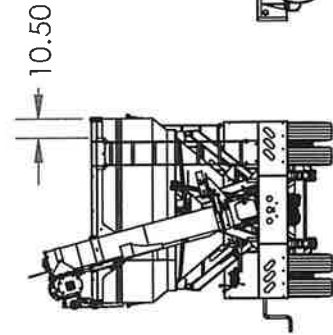

NOTE:
LADDER MUST FLOAT FREELY WHEN ASSEMBLED,
TO PREVENT DAMAGE FROM TRAILER MOVING

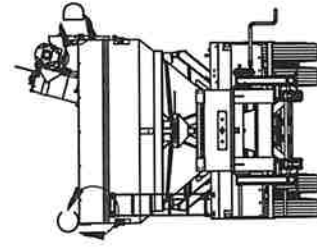

MT600900TMLI
1/25/18

MT600/MT900 TRUCK MOUNT LADDER PARTS ILLUSTRATION

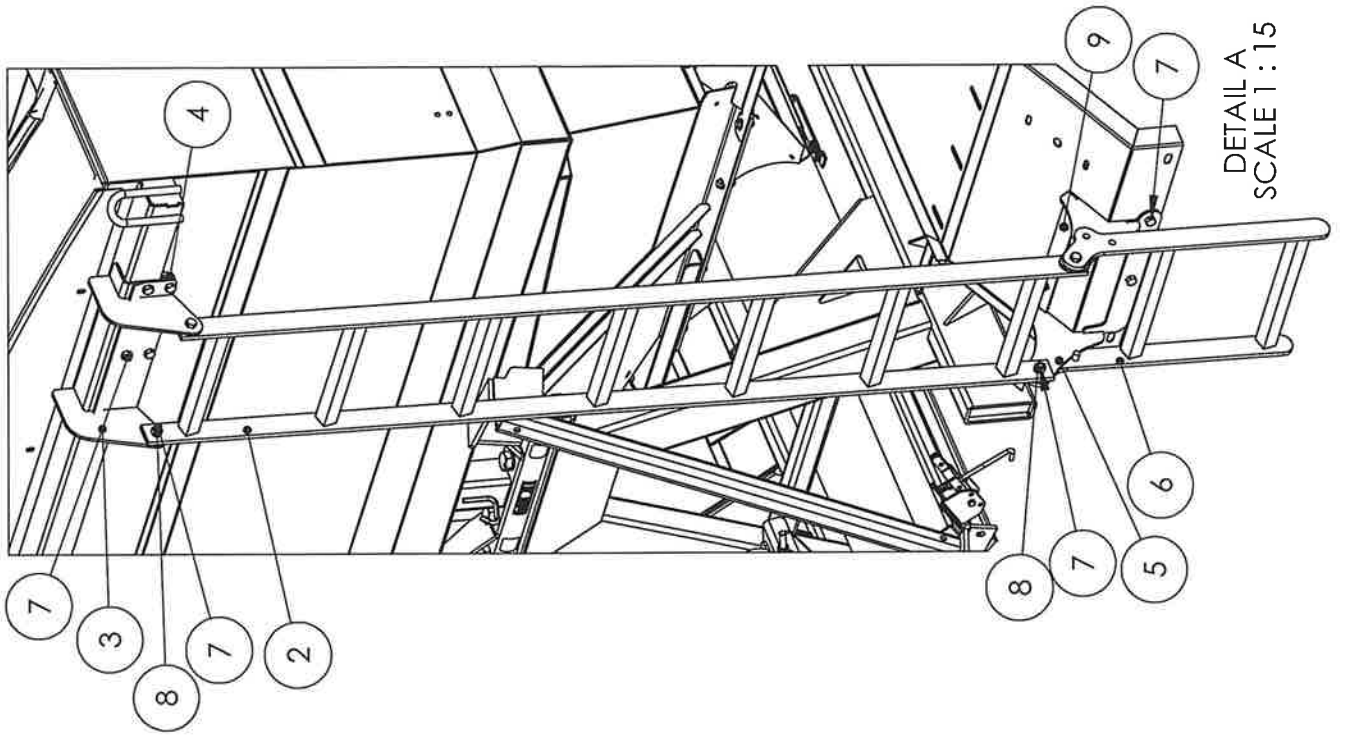

DETAIL A
SCALE 1:15

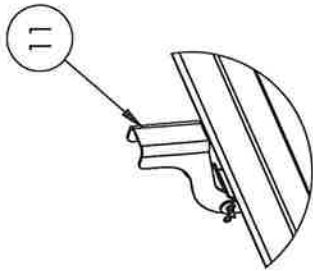

DETAIL B
SCALE 1:10

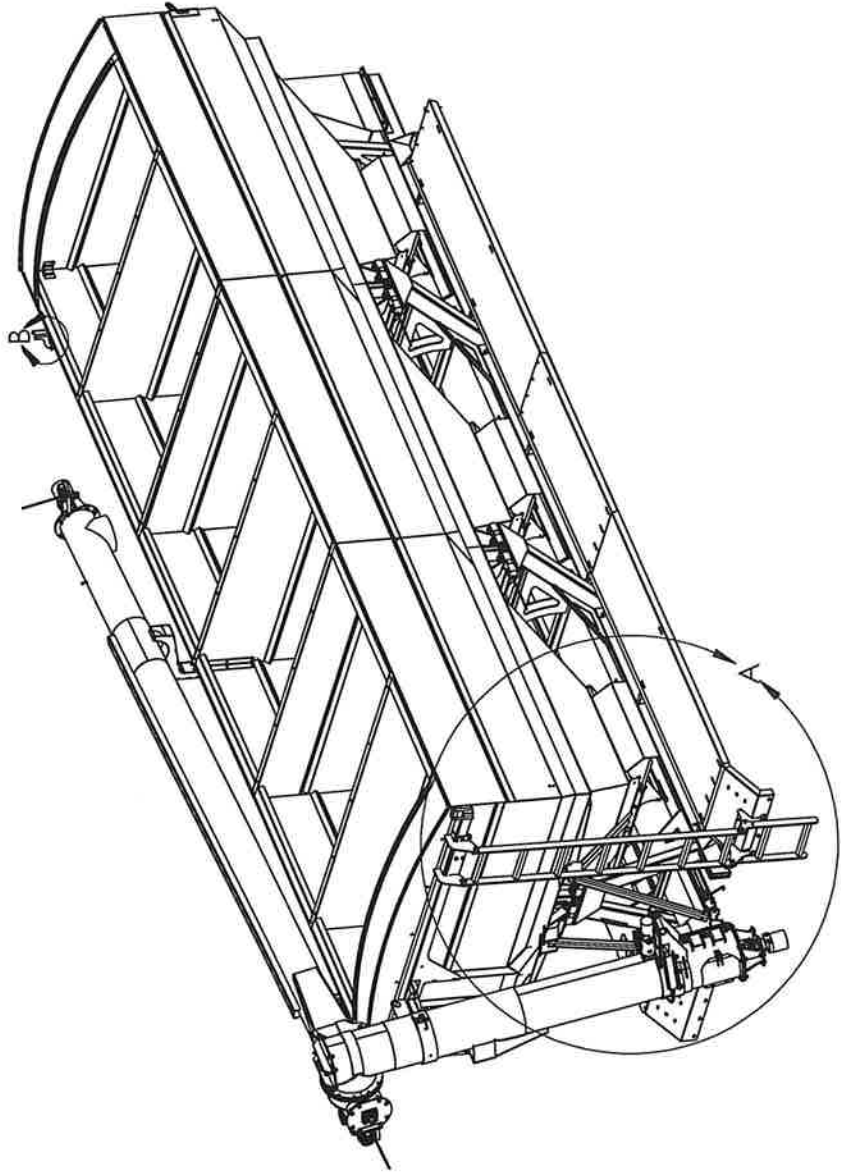

MT600/MT900 TRUCK MOUNT LADDER PARTS LIST

ITEM NO.	PART NUMBER	DESCRIPTION	QTY.
1	WITH FENDERS	MT600 OR MT900 TRUCK MOUNT WITH FENDER	1
2	47076500	LADDER	1
3	47076505	LADDER BRACKET	1
4	76508	CLAMP PLATE	1
5	47076624	LADDER MOUNT	1
6	47076651	LADDER EXT	1
7	18022026	BOLT, HEX HD 1/2-13 X 1 1/2 LG SS	12
8	18567400	NUT SS NYLOCK 1/2	12
9	18056824	BOLT HX CAP G5 NC ZC 3/8 X 1 1/4	2
10	18459200	NUT 3/8 NYLOCK	2
11	4003260	TARP STOP (SUPPLIED W/ ROLL TARP)	2

NOTE:
LADDER MUST FLOAT FREELY WHEN ASSEMBLED,
TO PREVENT DAMAGE FROM TRAILER MOVING

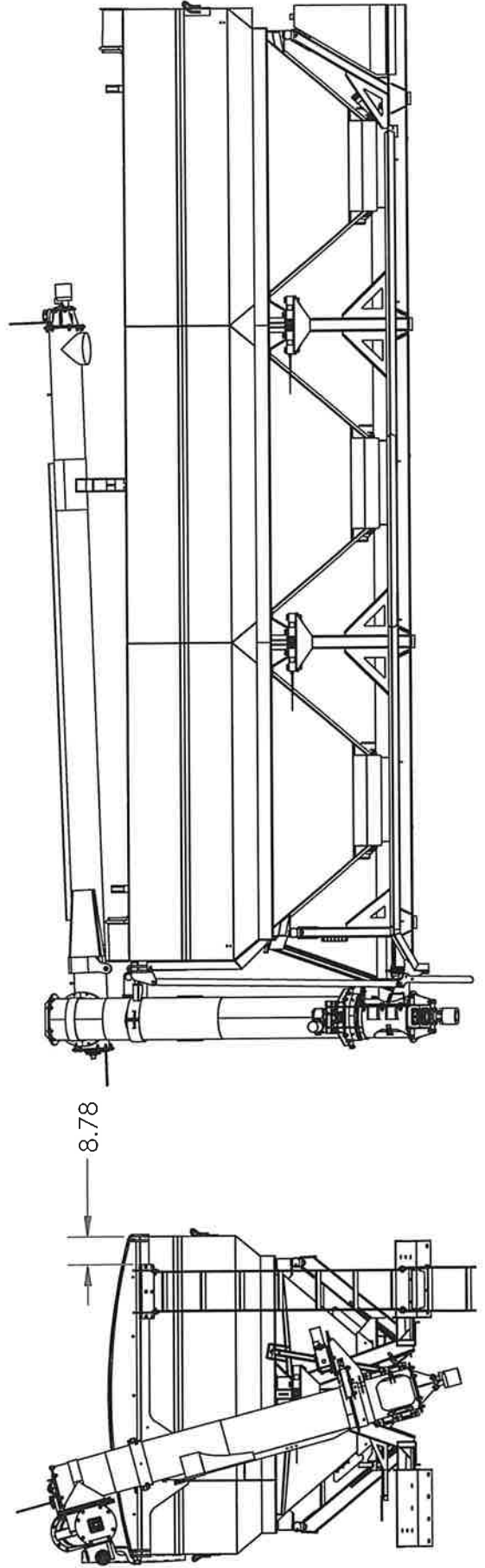

MT600TA MOUNTING OPTIONS

MT600TAMO
rev 3-10-21

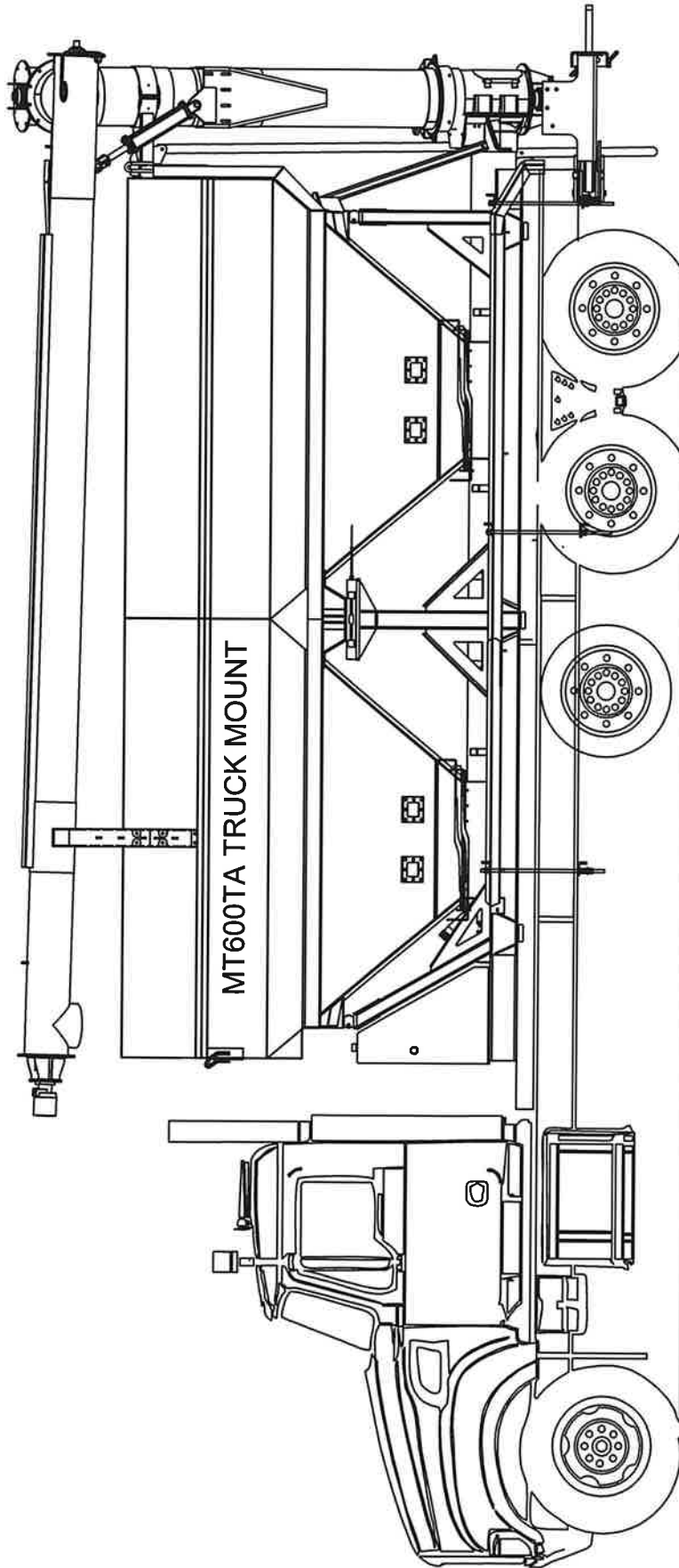

TRUCK MOUNT OPTION #1

PART #	DESCRIPTION	QTY
18384	ROD, MOUNTING 5/8	12
18386	SPRING, DIE	4
18417900	NUT, 5/8 NC ZC	40
18457900	LOCKNUT, 5/8 NC	8
18851600	WASHER, FLAT 5/8 SAE	4
75739	BRACKET, ANGLE	12

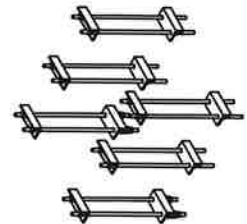

TRUCK MOUNT OPTION #2

PART #	DESCRIPTION	QTY
47076581	LATCH ARM (UPPER)	6
76577	LOCK PLATE	6
47076645	SHORT MTG ARM (LOWER)	6
18387	SPRING, DIE	2
18851800	WASHER, FLAT 3/4 SAE ZC	12
18098470	BOLT, HX 3/4 X 7 GR 8 NC ZC	2
18458452	NUT, LOCK 3/4 NC ZC	6
18097926	BOLT, HX 5/8 X 1 1/2 NC GR 8 NC ZC	6
18458451	NUT, LOCK 5/8 NC	12
18851600	WASHER, FLAT 5/8 SAE	24
18057930	BOLT, HX 5/8 X 2 GR 8 NC ZC	12
18098443	BOLT, HX 3/4 X 4 GR 8 NC ZC	4

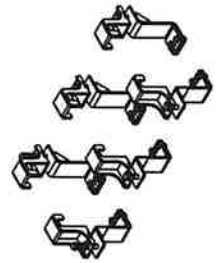

MT900TA MOUNTING OPTIONS

MT900TATMO
REV 3/10/21

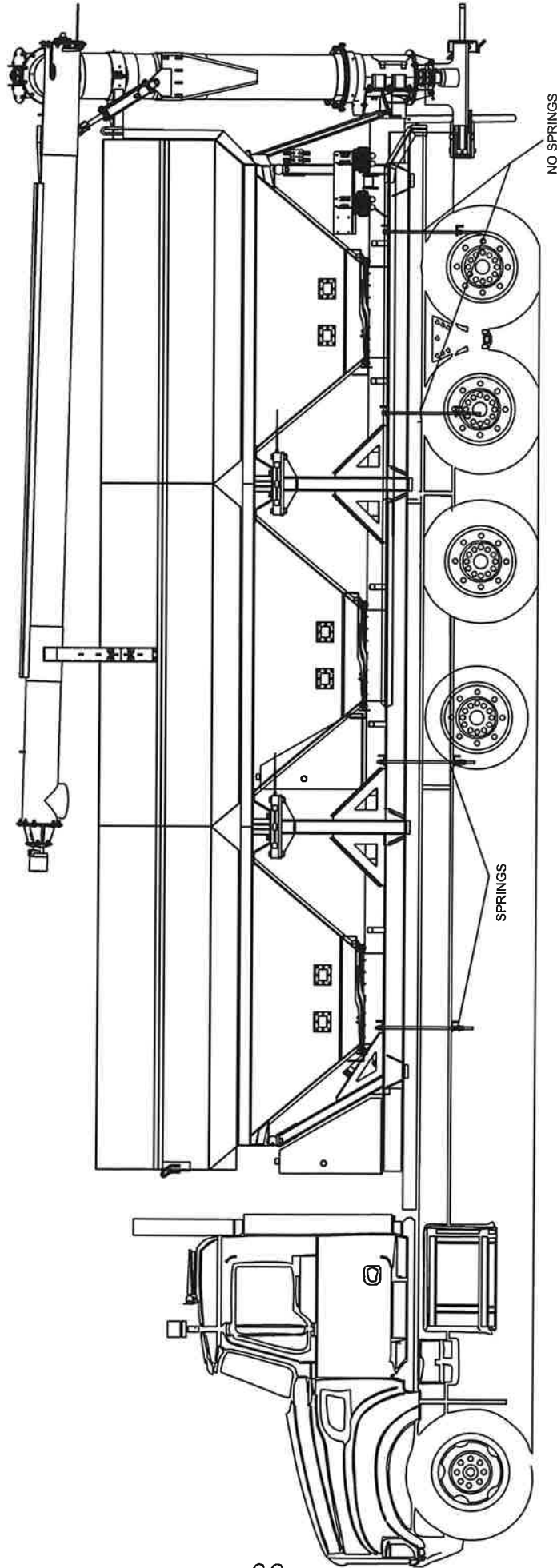

TRUCK MOUNT OPTION #1

PART #	DESCRIPTION	QTY
18386	ROD, MOUNTING 5/8	16
18387	SPRING, DIE	8
18417900	NUT, 5/8 NC ZC	48
18457900	LOCKNUT 5/8 NC	16
18851600	WASHER, FLAT 5/8 SAE	8
75739	BRACKET, ANGLE	16

TRUCK MOUNT OPTION #2

PART #	DESCRIPTION	QTY
47076581	LATCH ARM (UPPER)	8
76577	LOCK PLATE	8
47076582	LONG MTG ARM (LOWER)	8
18387	SPRING, DIE	4
18851800	WASHER, FLAT 3/4 SAE ZC	16
18098470	BOLT, HX 3/4 X 7 GR 8 NC ZC	4
18458452	NUT, LOCK 3/4 NC ZC	8
18097926	BOLT, HX 5/8 X 1 1/2 NC GR8 NC ZC	8
18458451	NUT, LOCK 5/8 NC	16
18851600	WASHER, FLAT 5/8 SAE	32
18057930	BOLT, HX 5/8 X 2 GR 8 NC ZC	16
18098443	BOLT, HX 3/4 X 4 GR 8 NC ZC	4

WELD ON TRUCK MOUNT BRACKETS

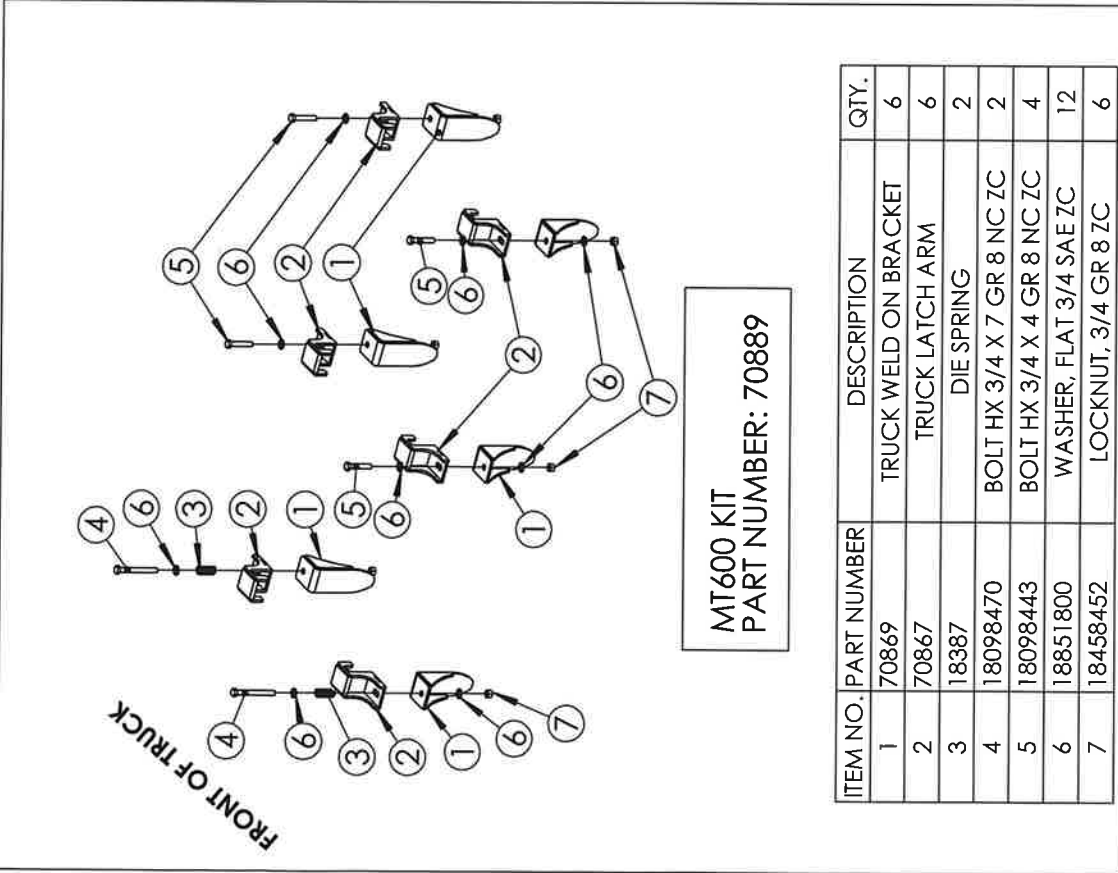

ITEM NO.	PART NUMBER	DESCRIPTION	QTY.
1	70869	TRUCK WELD ON BRACKET	6
2	70867	TRUCK LATCH ARM	6
3	18387	DIE SPRING	2
4	18098470	BOLT HX 3/4 X 7 GR 8 NC ZC	2
5	18098443	BOLT HX 3/4 X 4 GR 8 NC ZC	4
6	18851800	WASHER, FLAT 3/4 SAE ZC	12
7	18458452	LOCKNUT, 3/4 GR 8 ZC	6

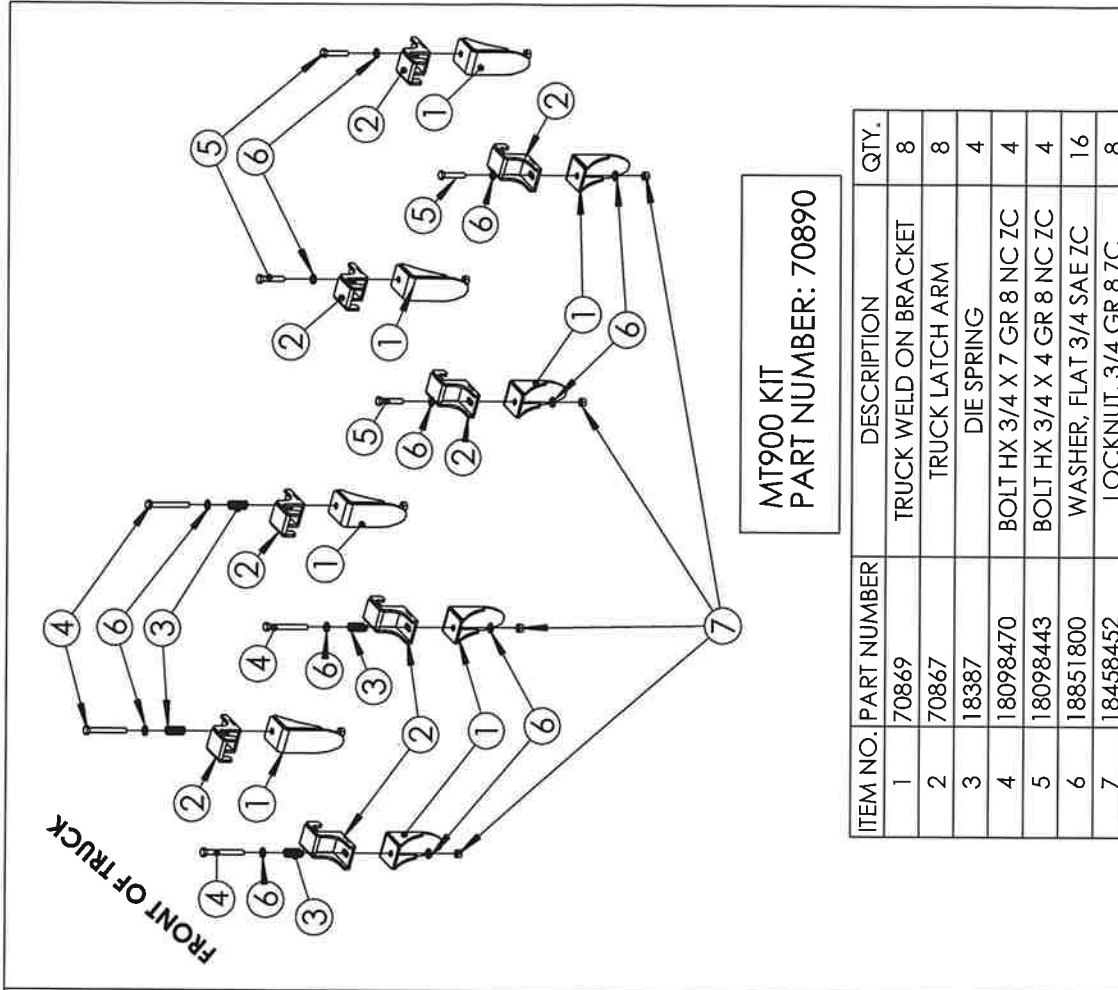

ITEM NO.	PART NUMBER	DESCRIPTION	QTY.
1	70869	TRUCK WELD ON BRACKET	8
2	70867	TRUCK LATCH ARM	8
3	18387	DIE SPRING	4
4	18098470	BOLT HX 3/4 X 7 GR 8 NC ZC	4
5	18098443	BOLT HX 3/4 X 4 GR 8 NC ZC	4
6	18851800	WASHER, FLAT 3/4 SAE ZC	16
7	18458452	LOCKNUT, 3/4 GR 8 ZC	8

WELD ITEM 1 UNTO TRUCK FRAME USING 1/4 FILLET WELD AROUND THE PERIMETER

MT900TA TRAILER MOUNTING HARDWARE

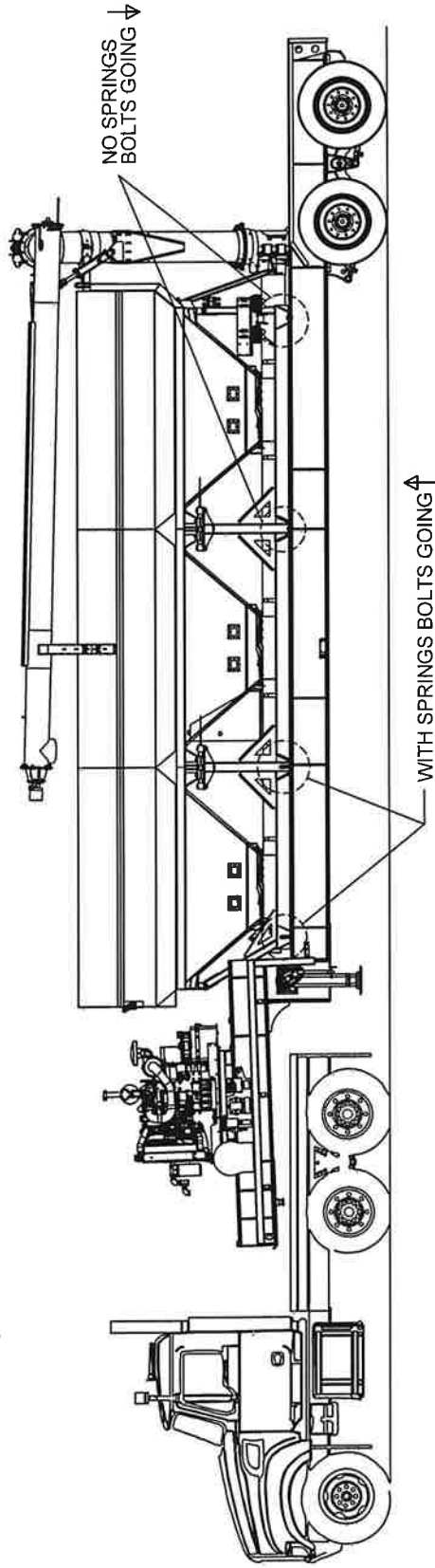

PART NUMBER	QTY	PART NUMBER
18058452M	4	BOLT, HX 3/4 X 5 NC (MAGNI)
18098500M	4	BOLT, HX 3/4 X 1 3/4 NC (MAGNI)
18458400M	8	NUT, CENTER LOCK 3/4 NC (MAGNI)
18387	4	DIE SPRING

MT900 TRAILER OPTIONS

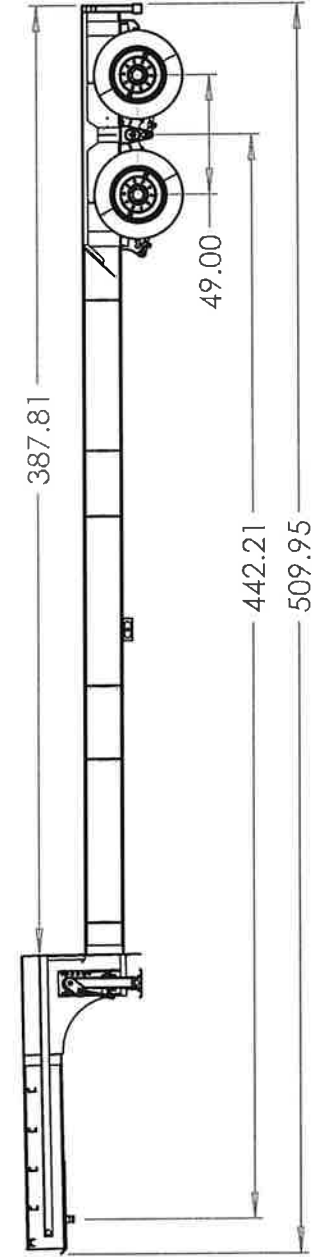

PART NUMBER: 3000344
 (MT24-42TA)
 42' TANDEM AXLE TRAILER

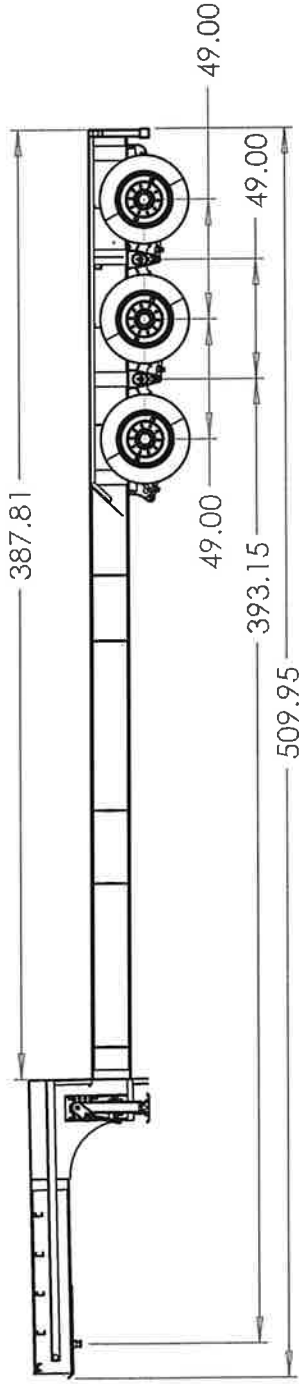

PART NUMBER: 3001459
 (MT24-42TA TRJ)
 42' TRIPLE AXLE TRAILER

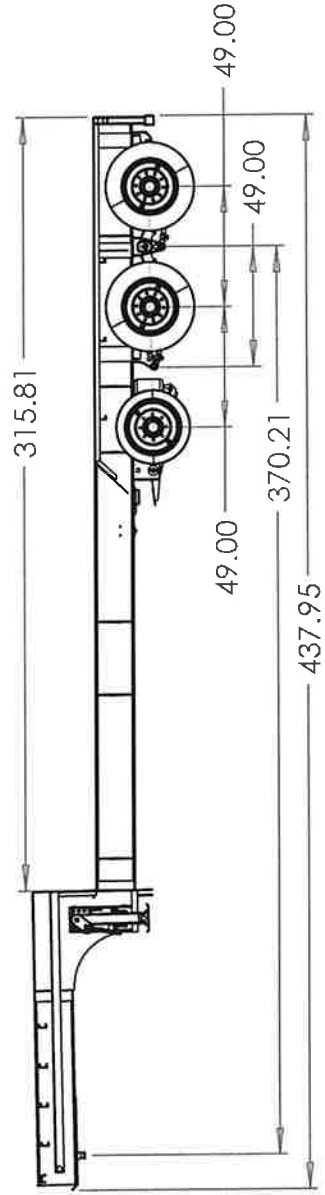

PART NUMBER: 3001431
 (MT24-36TA-LA)
 36' TRAILER, TRIPLE AXLE
 W/ FRONT LIFT AXLE

KESISO
RV 1/24/20

KUBOTA 83.1 HP ENGINE SKID

ILLUSTRATION
PART NUMBER # 48300383
2017-2020

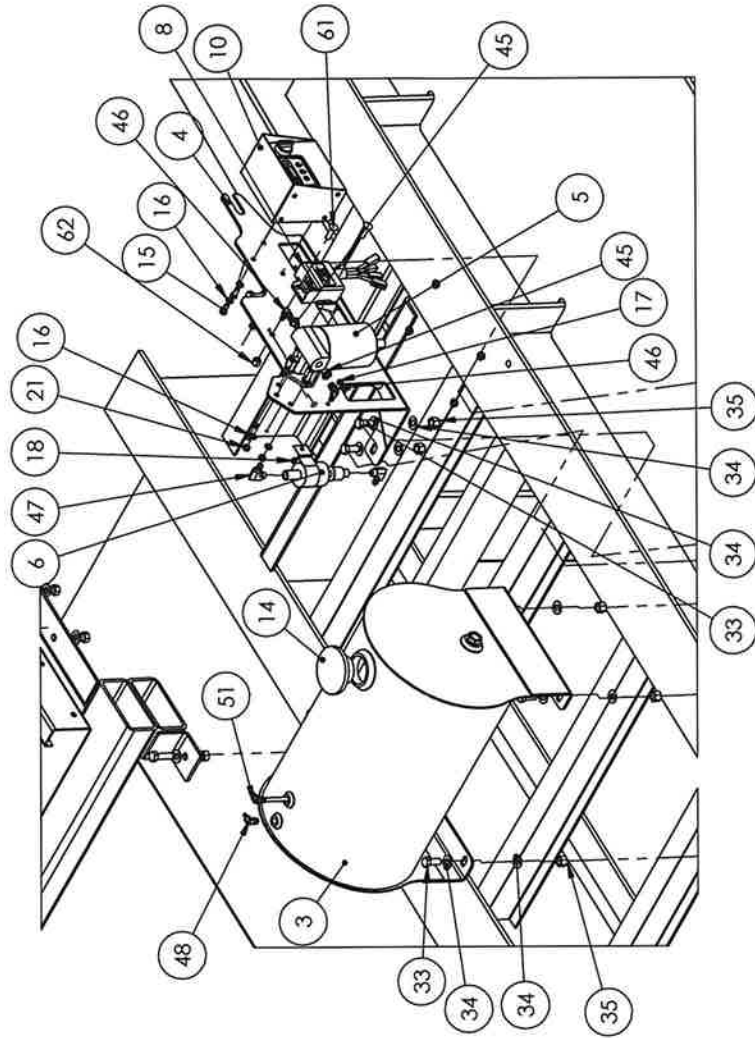
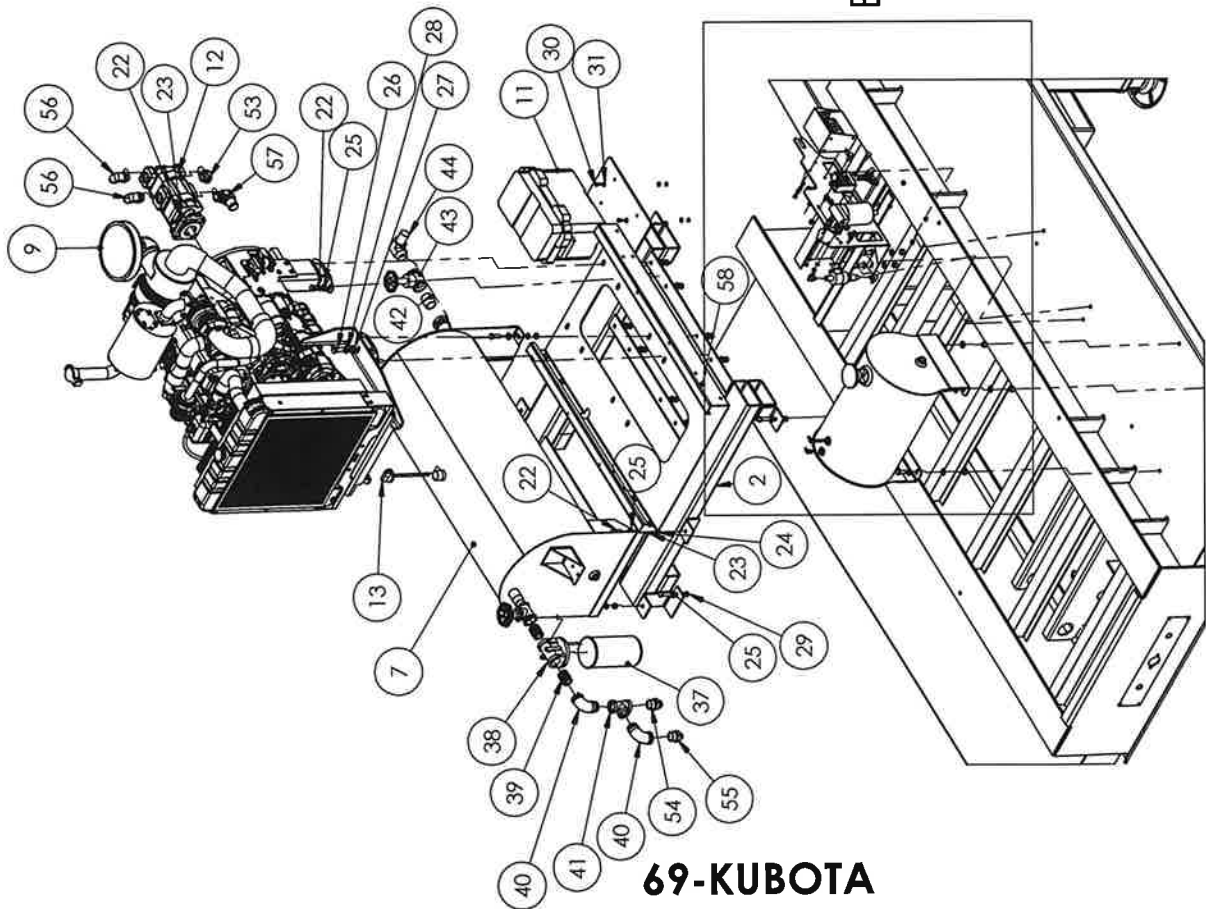

DETAIL B

KUBOTA 83.1 HP ENGINE SKID (P/N: 48300383) PART LISTING

KESLST
REV 2/5/20

ITEM NO.	PART NUMBER	DESCRIPTION	QTY.
2	76593	ENGINE SKID	1
3	48300314	FUEL TANK 14 GALLON	1
4	47076587	CONTROL PANEL W/LDMT	1
5	4309-3123	FUEL SEPARATOR (P/N: 4309)- FILTER (P/N: 3123)	1
6 *	FUEL PUMP (E8016SX)	12V FUEL PUMP	1
7	48300310	58 GALLON OIL TANK	1
8 **	AGRICOVER CONTROL	AGRICOVER CONTROL	1
9	AG-V3800	83 HP KUBOTA DIESEL ENGINE	1
10 *		DSE START BOX (INCLUDED W/ ENGINE)	1
11	01353	BATTERY BOX W/ LID	1
12	M1900TAPUMP	HYDRAULIC PUMP	1
13	48300330	DIP STICK	1
14	60001	FUEL TANK CAP	1
15	18056418	BOLT, HX CAP 5/16-18 X 3/4 LG	3
16	18891110	WASHER, LOCK 5/16 ZC	6
17	18092020	BOLT PAN HEAD 1/4-20 X 3/4 LG ZC	1
18	18495700	NUT HX SER FLG 1/4 NC ZC	1
19	18056424	BOLT, HX CAP 5/16-18 X 1 1/4 LG	3
20	18811100	WASHER, FLAT 5/16 ZC	3
21	18406400	NUT HX 5/16 ZC	3
22	18057426	BOLT, HX CAP 1/2-13 X 1 1/2 LG	16
23	18891400	WASHER, 1/2 LOCK ZC	8
24	18417400	NUT, HX 1/2 NC ZC	4
25	18811400	WASHER, FLAT 1/2 ZC	24
26	18055600	BOLT HX CAP M16 X 20 X 40 LG ZP (METRIC)	4
27	18811600	WASHER, FLAT 5/8 ZC	4
28	18891600	WASHER LOCK 5/8 ZC	4
29	18457650	NUT CTR LOCK 1/2 ZP ZC	12
30	18706421	BOLT, HX CAP 5/16-18 X 3/4 LG SS	4

ITEMS MARKED WITH * ARE INCLUDED WITH ITEM 8 AG-V3800 ENGINE

ITEMS MARKED WITH ** ARE INCLUDED WITH THE AGRICOVER SYSTEM

ITEM 58 INCLUDED WITH ENGINE ENCLOSURE (P/N: 47076689),
FOR ENGINE ENCLOSURE SEE PGS 75-6

ALSO INCLUDED, BUT NOT SHOWN ENGINE OIL DRAIN KIT P/N: 48300450

ITEM NO.	PART NUMBER	DESCRIPTION	QTY.
31	18991100	WASHER, FLAT 5/16 SS	8
32	18991110	WASHER, LOCK 5/16 SS	4
33	18475240	BOLT HX CAP 1/2-13 X 1 1/4 LG SS	8
34	18824800	WASHER FLAT 1/2 SS	16
35	18567400	NUT SS NYLOCK 1/2	8
36	18057428	BOLT HX CAP 1/2-13 X 1 3/4 ZC	4
37	SE25	OIL FILTER ELEMENT 10 MIL	1
38	20239	OIL FILTER HEAD 1 1/4 NPT	1
39	72330	CLOSE NIPPLE 1 1/4" NPT	2
40	72355	1 1/4 STREET ELBOW	2
41	72342	PIPE TEE 1 1/4 NPT	1
42	72390	CLOSE NIPPLE 1 1/2	1
43	51497	GATE VALVE 1 1/2 NPT	1
44	4501-24-24	1 1/2 HOSE ADAPTER	1
45	200810	REDUCER	2
46	4290-05-04	FITTING, 5/16 HOSE BARB TO 1/4 NPT X 90 DEG	2
47	4290-05-02	5/16 HOSE BARB TO 1/8-27 NPT PIPE ELBOW	2
48	4290-03-04	FITTING, 3/16 HOSE BARB TO 1/4 NPT X 90 DEG	1
49	02006	1 1/4" GATE VALVE	1
50	1091809	FLUID LEVEL SIGHT GLASS	1
51	47076765	SUCTION TUBE WELD.	1
52	18987700	NUT 5/16 SERR FLG	4
53	6408-20	#20 O-RING PLUG	1
54	2404-16-20	ADAPTER 1 1/4 NPT M X #16 JIC M	1
55	2404-12-20	ADAPTER 1 1/4 MNPT X #12 MJIC	1
56	6801-12-16	FITTING ELBOW #12 JIC O- RING	2
57	4601-24-20	HOSE BARB 90	1
58	76690W	BASE PANEL	1
59	72220	DRAIN PLUG 3/4 NPT	2
60	1044762	2" X 1 1/2" EXTERNALLY MOUNTED STRAINER W/ BYPASS	1
61	18055501	BOLT CARRIAGE SS 3/8-16 X 1 1/4" LG	2
62	18566400	NUT SS NYLOCK 3/8	2

ALSO INCLUDED (NOT SHOWN)

FBA12684100 - FUEL LINE CLIPS - QTY 8

FBA12683100 - HOSE LINE CLAMPS - QTY 2

12003501 - SUCTION HOSE - QTY 1
(1 1/2 X 22 3/8)

148505 - BATTERY CABLE 48" - 1

01351 - BATTERY CABLE 38" - 1

90312A291 - 8" LG WIRE LANYARD - 1

31-7237 - GROUP 27 BATTERY - 1

H176 - 5/16 GAS LINE (AS NOTED)

FUEL PUMP TO SEPARATOR - 1.75"

TANK TO PUMP - 1.75"

FILTER TO MOTOR - 3'

TANK TO MOTOR - 3'

FLUIDS NEEDED:

15W-40 OIL - 3.5 US GALLONS (P/N: 1540)

LONG LIFE COOLANT (ETHYLENE

GLYCOL) MIX 50/50 WITH SOFT

WATER - 3 GALLONS TOTAL (P/N: 1081)

HYDRAULIC OIL 56 GALLONS (P/N: 4050)

ALSO REQ'D:

- BASE HOSE KIT

P/N: 1124063 - QTY 1

- BASE FITTING KIT

P/N: 1120446-QTY 1

ADDITIONAL HOSES REQ'D:

1 - 612424 1 - 612142

1 - 612404 1 - 616394

1 - 612287

(SEE HYD. PLUMBING CHART PGS. 95-6)

KUBOTA 83.1 HP ENGINE SKID ENGINE SKID DETAIL

rv 1/24/20

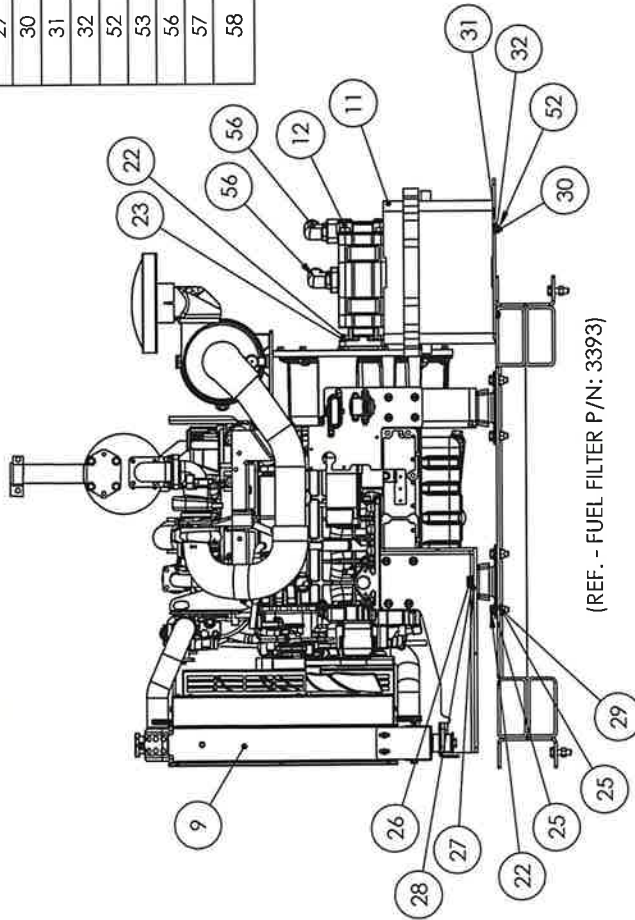
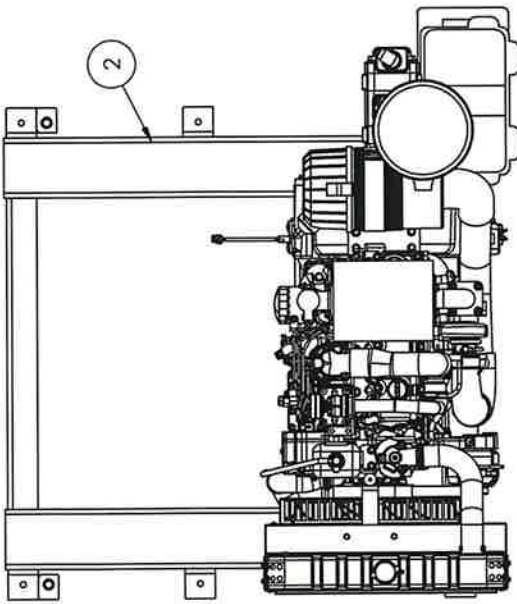

ITEM NO.	PART NUMBER	DESCRIPTION	QTY.
2	76593	ENGINE SKID	1
9	AG-V3800	83 HP KUBOTA DIESEL ENGINE	1
11	01353	BATTERY BOX W/ LID	1
12	MT900TAPUMP	HYDRAULIC PUMP	1
22	18057426	BOLT, HX CAP 1/2-13 X 1 1/2 LG	12
23	18891400	WASHER, 1/2 LOCK ZC	4
25	18811400	WASHER, FLAT 1/2 ZC	16
26	18055600	BOLT HX CAP M16 X 2.0 X 40 LG ZP (METRIC)	4
27	18811600	WASHER, FLAT 5/8 ZC	4
28	18891600	WASHER LOCK 5/8 ZC	4
29	18457650	NUT CTR LOCK 1/2 ZP ZC	8
30	18706421	BOLT, HX CAP 5/16-18 X 3/4 LG SS	4
31	18991100	WASHER, FLAT 5/16 SS	8
32	18991110	WASHER, LOCK 5/16 SS	4
52	18987700	NUT 5/16 SERR FLG	4
53	6408-20	# 20 O-RING PLUG	1
56	6801-12-16	FITTING ELBOW #12 JIC O-RING	2
57	4601-24-20	HOSEBARB 90	1
58	76690W	BASE PANEL	1

ALSO INCLUDED, BUT NOT SHOWN ENGINE OIL DRAIN KIT P/N: 48300450 (SEE PG. 74A)

ITEM 58 IS INCLUDED WITH THE ENCLOSURE KIT. IT IS NOT SHOWN FOR CLARITY. ITEM 58 GETS SET ON THE SKID FIRST, THEN THE ENGINE ON TOP OF IT.

PUMP W/ FITTINGS IS P/N:48300501 AND INCLUDES ITEMS 12, 53, AND 56-57

KUBOTA MANUALS AVAILABLE FROM NORTHERN POWER:

KUBOTA OWNERS MANUAL P/N: 1J411-89115

FEDERAL & CALIFORNIA EMISSION CONTROL SYSTEM BOOK P/N:1G511-89819

rev 1/24/20

KUBOTA 83.1 HP ENGINE SKID CONTROL PANEL DETAIL

ITEM NO.	PART NUMBER	DESCRIPTION	QTY.
4	47076587	CONTROL PANEL W/DMT	1
5	4309-3123	FUEL SEPARATOR (P/N: 4309)- FILTER (P/N:3123)	1
6	FUEL PUMP (E8016SX)	12V FUEL PUMP	1
8	AGRICOVER CONTROL	AGRICOVER CONTROL	1
10	--	DSE START BOX (INCLUDED W/ ENGINE)	1
15	18056418	BOLT, HX CAP 5/16-18 X 3/4 LG	3
16	18891110	WASHER, LOCK 5/16 ZC	6
17	18092020	BOLT PAN HEAD 1/4-20 X 3/4 LG ZC	1
18	18495700	NUT HX SER FLG 1/4 NC ZC	1
19	18056424	BOLT, HX CAP 5/16-18 X 1 1/4 LG	3
20	18811100	WASHER, FLAT 5/16 ZC	3
21	18406400	NUT HX 5/16 ZC	3
33	18475240	BOLT HX CAP 1/2-13 X 1 1/4 LG SS	4
34	18824800	WASHER FLAT 1/2 SS	8
35	18567400	NUT SS NYLOCK 1/2	4
45	200810	REDUCER	2
46	4290-05-04	FITTING, 5/16 HOSE BARB TO 1/4 NPT X 90 DEG	2
47	4290-05-02	5/16 HOSE BARB TO 1/8-27 NPT PIPE ELBOW	2
61	18055501	BOLT CARRIAGE SS 3/8-16 X 1 1/4	2
62	18566400	NUT SS NYLOCK 3/8	2

(ITEMS 33-35 ARE ALSO USED ON THE FUEL TANK DETAIL)

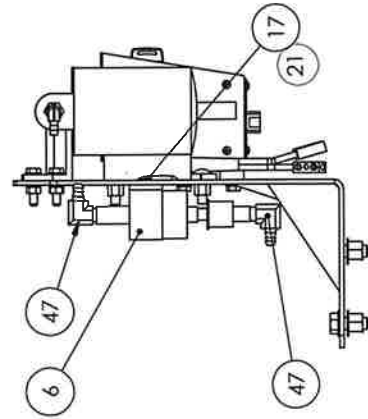
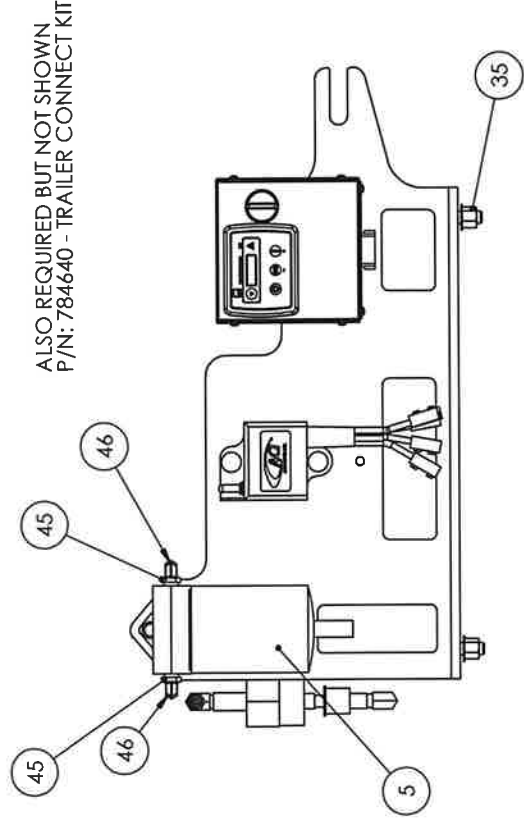
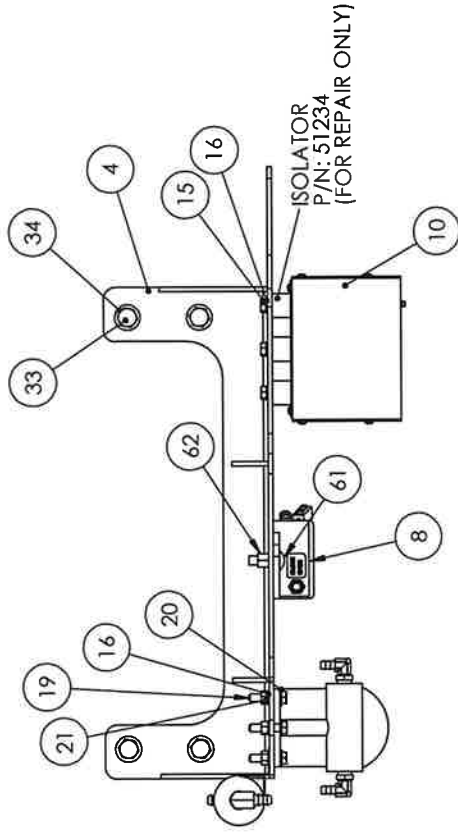

rev 1/24/20

KUBOTA 83.1 HP ENGINE SKID FUEL TANK DETAIL

NOTE:
MOUNT FUEL TANK FAR ENOUGH
AWAY FROM THE ENGINE, SO
THAT THE FUEL **DOES NOT** GET
PINCHED.

ITEM NO.	PART NUMBER	DESCRIPTION	QTY.
3	48300314	FUEL TANK 14 GALLON	1
14	60001	FUEL TANK CAP	1
33	18475240	BOLT HX CAP 1/2-13 X 1 1/4 LG SS	8
34	18824800	WASHER FLAT 1/2 SS	16
35	18567400	NUT SS NYLOCK 1/2	8
48	4290-03-04	FITTING, 3/16 HOSE BARB TO 1/4 NPT X 90 DEG	1
50	1091809	FLUID LEVEL SIGHT GLASS	1
51	47076765	SUCTION TUBE WELD.	1
59	72220	DRAIN PLUG 3/4 NPT	2

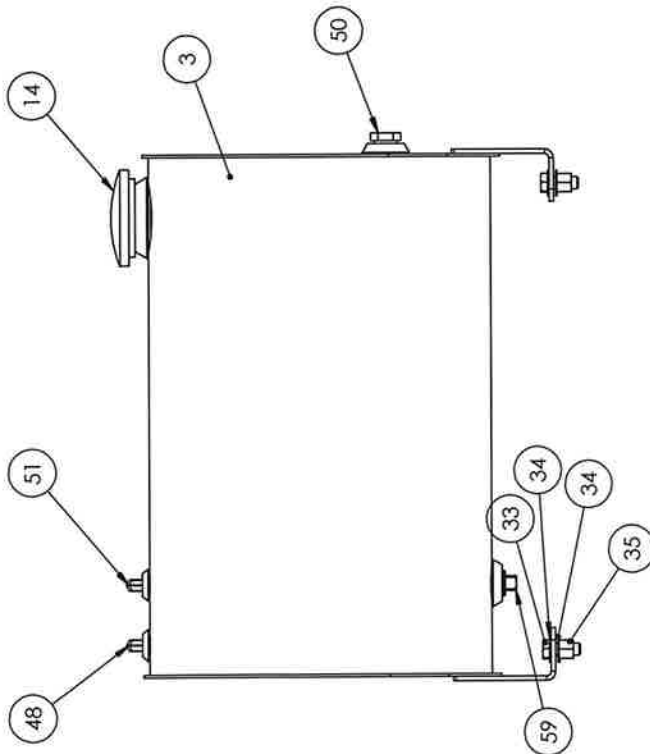

(ITEMS 33-35 ARE ALSO USED ON THE CONTROL PANEL DETAIL)
(ITEM 59 IS ALSO USED ON THE OIL TANK DETAIL)

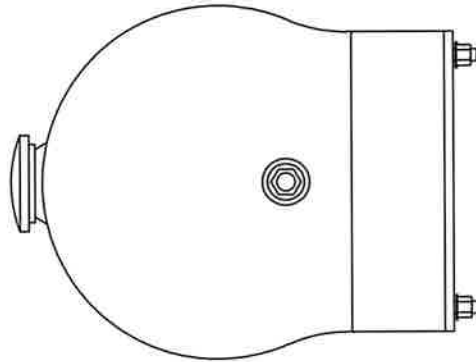

KUBOTA 83.1 HP ENGINE SKID OIL TANK DETAIL

ITEM NO.	PART NUMBER	DESCRIPTION	QTY.
7	48300310	58 GALLON OIL TANK	1
13	48300330	DIP STICK	1
22	18057426	BOLT, HX CAP 1/2-13 X 1 1/2 LG	4
23	18891400	WASHER, 1/2 LOCK ZC	4
24	18417400	NUT, HX 1/2 NC ZC	4
25	18811400	WASHER, FLAT 1/2 ZC	8
29	18457650	NUT CTR LOCK 1/2 ZP ZC	4
36	18057428	BOLT HX CAP 1/2-13 X 1 3/4 ZC	4
37	SE25	OIL FILTER ELEMENT 10 MIL	1
38	20239	OIL FILTER HEAD 1 1/4 NPT	1
39	72330	CLOSE NIPPLE 1 1/4" NPT	2
40	72355	1 1/4 STREET ELBOW	2
41	72342	PIPE TEE 1 1/4 NPT	1
42	72390	CLOSE NIPPLE 1 1/2	1
43	51497	GATE VALVE 1 1/2 NPT	1
44	4501-24-24	1 1/2 HOSE ADAPTER	1
49	02006	1 1/4" GATE VALVE	1
54	2404-16-20	ADAPTER 1 1/4 NPT M X #16 JIC M	1
55	2404-12-20	ADAPTER 1 1/4 MNPT X #12 MJIC	1
59	72220	DRAIN PLUG 3/4 NPT	1
60	1044762	2" X 1 1/2" EXTERNALLY MOUNTED STRAINER W/ BYPASS	1

(ITEM 59 IS USED ON THE FUEL TANK DETAIL ALSO)

OIL TANK W/ FITTINGS P/N: 47976593
INCLUDES ITEMS 7, 13, 37-44, 49, 54-5, AND 59-60

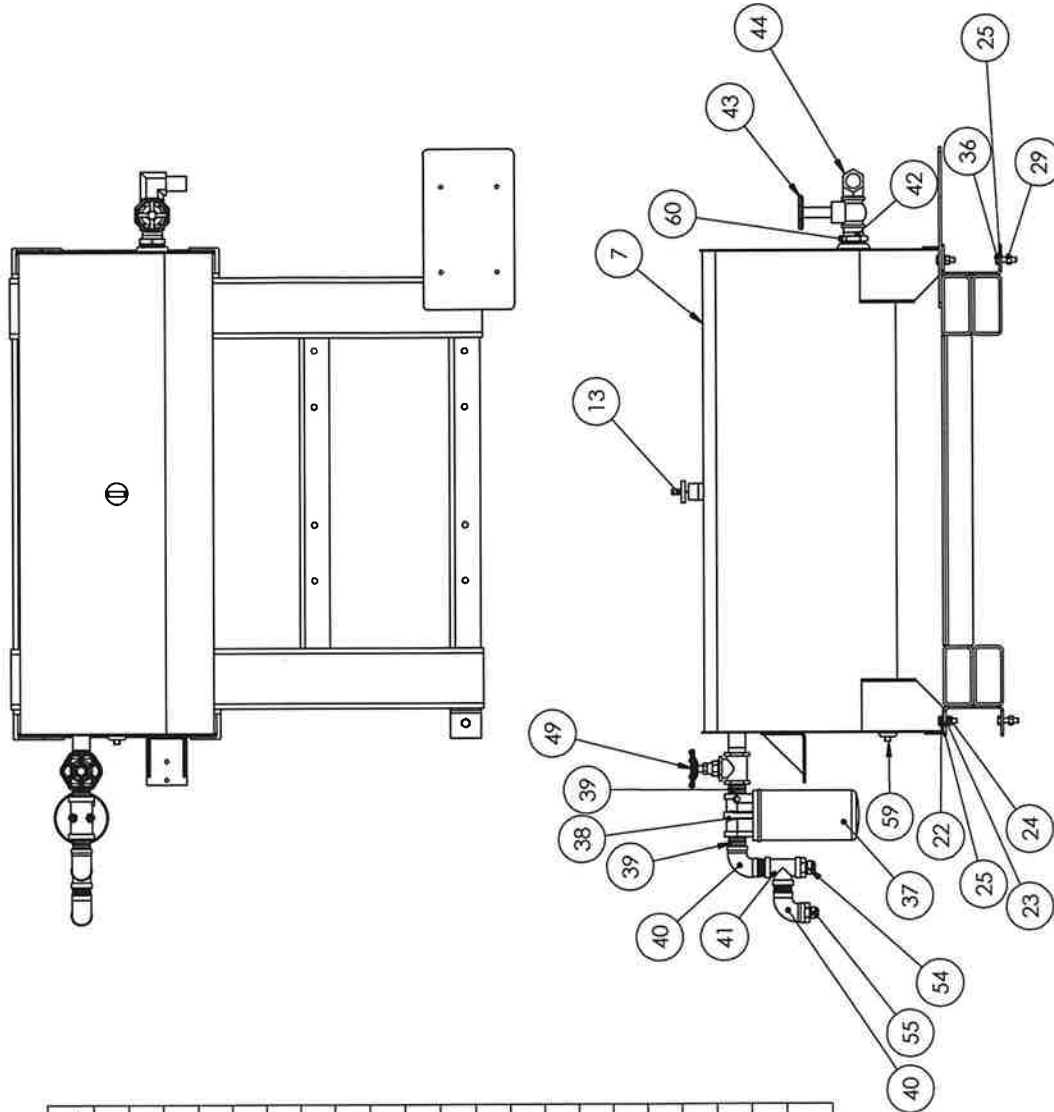



ENGINE (KUBOTA) OIL DRAIN KIT

PART NUMBER : #48300450

ITEM NO.	PART NUMBER	DESCRIPTION	QTY.
1	FG7BNS M22-1.5	ENGINE OIL DRAIN VALVE	1
2	1090671-1	5/8 FUEL LINE HOSE X 4 FT LG	1
3	1090671-2	HOSE CLAMP	2
4	4311-10-10	FITTING STEEL BARB X #10 FJICS	1
5	2408-10	PLUG #10 MJIC	1

ITEMS 2 - 5 ARE PURCHASED AS KIT # 1090671
 REMOVE ITEM 5 WHEN DRAINING, REPLACE WHEN FINISHED
 (ITEM #2 LENGTH NOT SHOWN TO SCALE)

74A-KUBOTA

THIS PAGE LEFT BLANK INTENTIONALLY

74B-KUBOTA

KUBOTA ENCLOSURE ILLUSTRATION

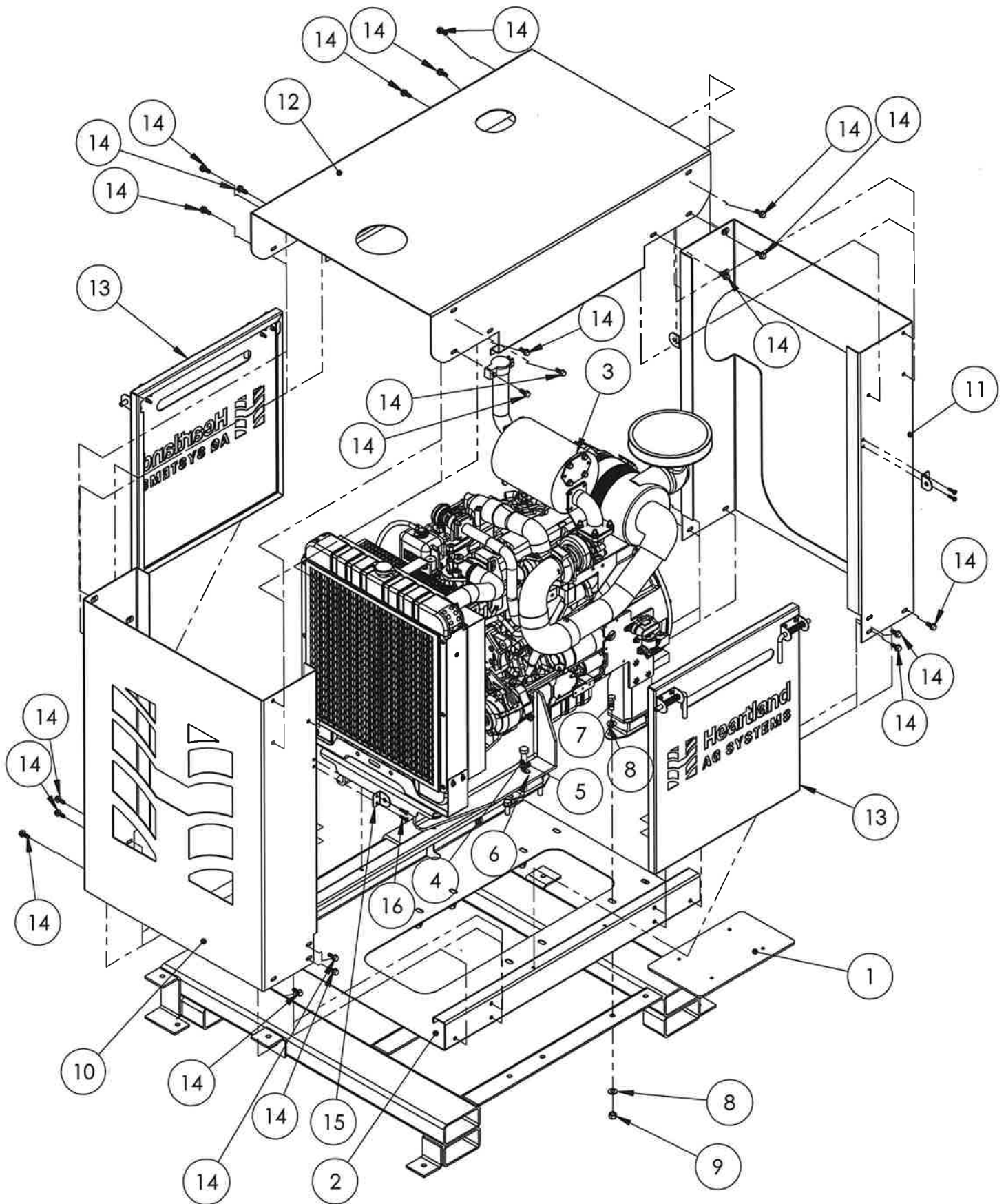

KUBOTA ENCLOSURE PART LIST

PART NUMBER: #47076689

ITEM NO.	PART NUMBER	DESCRIPTION	QTY.
1	76593	ENGINE SKID	1
2	76690W	BASE PANEL	1
3	AG-V3800	83 HP KUBOTA DIESEL ENGINE	1
4	18055600	BOLT HX CAP M16 X 2.0 X 40 LG ZP (METRIC)	4
5	18891600	WASHER LOCK 5/8 ZC	4
6	18811600	WASHER, FLAT 5/8 ZC	4
7	18057426	BOLT, HX CAP 1/2-13 X 1 1/2 LG	8
8	18811400	WASHER, FLAT 1/2 ZC	16
9	18457650	NUT CTR LOCK 1/2 ZP ZC	8
10	76691W	FRONT PANEL	1
11	76693W	REAR PANEL	1
12	76692	TOP PANEL	1
13	76670W	DOOR	2
14	7729-7731	3/8-16 x 3/4 LG FLANGE HEAD BOLT	24
15	3356A770-1	INCLUDED WITH 3356A770 LATCH	4
16	18055722	BOLT HX CAP 1/4-20 X 1"	8

NOTE:

ENCLOSURE KIT INCLUDES ITEMS 2, 10-14

ITEMS 1, 3-9 ARE SHOWN FOR REFERENCE ONLY

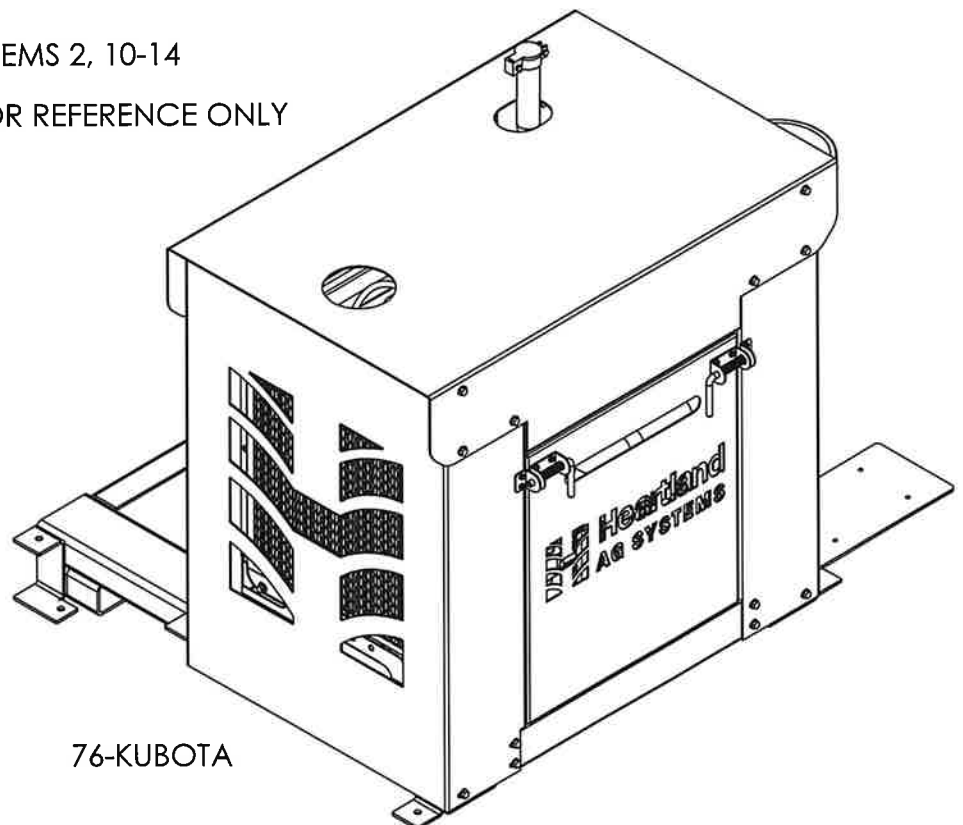

76-KUBOTA

CAT 88 HP ENGINE SKID

ILLUSTRATION
PART #: 48300384
2020-2021

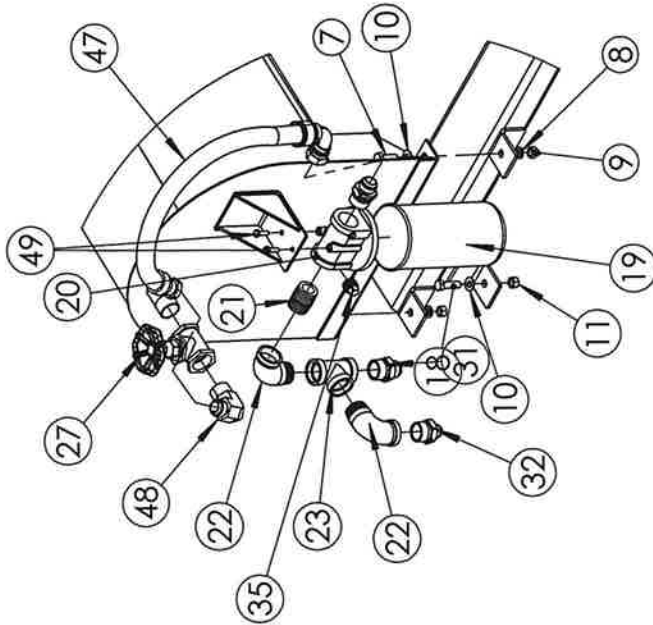
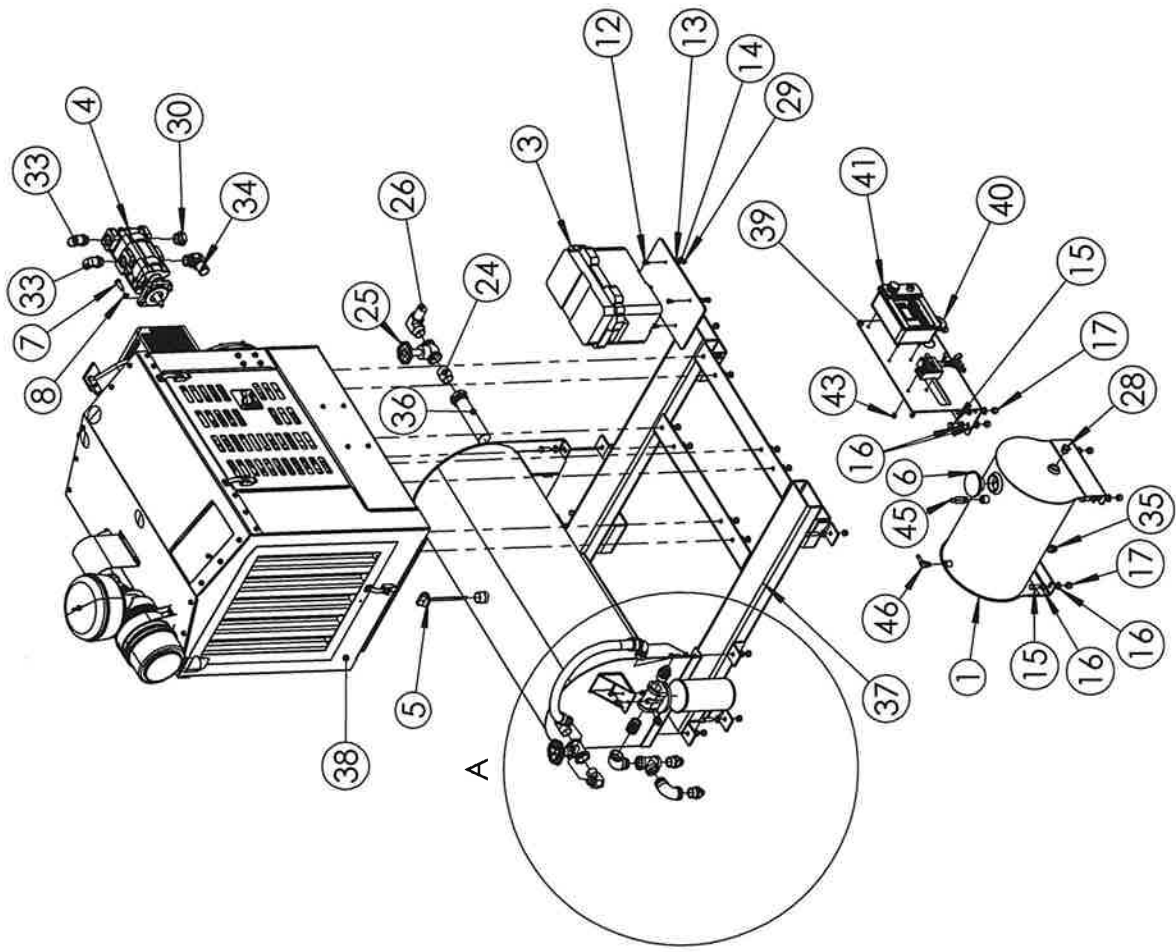

DETAIL A
SCALE 1:15

CAT 88 HP ENGINE SKID

BILL OF MATERIAL

PART #: 48300384

ITEM NO.	PART NUMBER	DESCRIPTION	QTY.
29	18987700	NUT 5/16 SERR FLG	4
30	6408-20	#20 O-RING PLUG	1
31	2404-16-20	ADAPTER 1 1/4 NPT M X #16 JIC M	2
32	2404-12-20	ADAPTER 1 1/4 MNPT X #12 MJIC	1
33	6801-12-16	FITTING ELBOW #12 JIC O-RING	2
34	4601-24-20	HOSEBARB 90	1
35	72220	DRAIN PLUG 3/4 NPT	2
36	1044762	2" X 1 1/2" EXTERNALLY MOUNTED STRAINER W/ BYPASS	1
37	70536	ENGINE SKID, PERKINS/CAT	1
38	393-3430	CAT 88 HP POWER UNIT	1
39	71017	CONTROL BOX WELDT	1
40	GROMMET	GROMMET	1
41	TEC-10 CONTROLLER	CAT CONTROL BOX (INCLUDED WITH POWER UNIT)	1
42	AGRICOVER CONTROL	AGRICOVER CONTROL	1
43	18566400	NUT SS NYLOCK 3/8	2
44	18176450	BOLT, CARRIAGE, 3/8-16 X 1	2
45	71088	ADAPTER ELBOW, 1/2 HOSE, 1/2 NPT MALE	1
46	71089	ADAPTER ELBOW, 3/8 HOSE, 3/8 NPT MALE	1
47	71103	19" HOSE WITH FITTINGS	1
48	2024-20-16	20 NPTM-16 JIC ELBOW	1
49	18026422	BOLT CAP SS 5/16 X 1	2

BOM CONTINUED ON NEXT PAGE

ITEM NO.	PART NUMBER	DESCRIPTION	QTY.
1	71082	FUEL TANK 14 GALLON, T4	1
2	48300310	58 GALLON OIL TANK	1
3	01353	BATTERY BOX W/ LID	1
4	1054947	HYDRAULIC PUMP	1
5	48300330	DIP STICK	1
6	60001	FUEL TANK CAP	1
7	18057426	BOLT, HX CAP 1/2-13 X 1 1/2 LG	16
8	18891400	WASHER, 1/2 LOCK ZC	8
9	18417400	NUT, HX 1/2 NC ZC	4
10	18811400	WASHER, FLAT 1/2 ZC	24
11	18457650	NUT CTR LOCK 1/2 ZP ZC	12
12	18706421	BOLT, HX CAP 5/16-18 X 3/4 LG SS	4
13	18991100	WASHER, FLAT 5/16 SS	8
14	18991110	WASHER, LOCK 5/16 SS	4
15	18475240	BOLT HX CAP 1/2-13 X 1 1/4 LG SS	8
16	18824800	WASHER FLAT 1/2 SS	16
17	18567400	NUT SS NYLOCK 1/2	8
18	18057428	BOLT HX CAP 1/2-13 X 1 3/4 ZC	4
19	SE25	OIL FILTER ELEMENT 10 MIL	1
20	20239	OIL FILTER HEAD 1 1/4 NPT	1
21	72330	CLOSE NIPPLE 1 1/4" NPT	1
22	72355	1 1/4 STREET ELBOW	2
23	72342	PIPE TEE 1 1/4 NPT	1
24	72390	CLOSE NIPPLE 1 1/2	1
25	51497	GATE VALVE 1 1/2 NPT	1
26	4501-24-24	1 1/2 HOSE ADAPTER	1
27	02006	1 1/4" GATE VALVE	1
28	1091809	FLUID LEVEL SIGHT GLASS	1

NOTE:
THE AGRICOVER CONTROL, TEC-10 CONTROLLER, AND GROMMET ARE INCLUDED WITH OTHER COMPONENTS AND SHOWN FOR ASSEMBLY PURPOSES ONLY.

CAT 88 HP ENGINE SKID

BILL OF MATERIAL

ITEMS INCLUDED BUT NOT SHOWN

PART NUMBER	DESCRIPTION	QTY
1090671	OIL DRAIN KIT	1
FBA12684100	FUEL LINE CLIPS	8
FBA12683100	HOSE LINE CLAMPS	2
12003501	SUCTION HOSE	1
148505	BATTERY CABLE 48" RED	1
01351	BATTERY CABLE 38" BLACK	1
31-7237	GROUP 27 BATTERY	1
4050	HYDRAULIC OIL	56
1124063	BASE HOSE KIT	1
1120446	BASE FITTING KIT	1
612424	HYD HOSE 3/4 X 424.00	1
612404	HYD HOSE 3/4 X 404.00	1
612287	HYD HOSE 3/4 X 287.00	1
612142	HYD HOSE 3/4 X 142.00	1
616402	HYD HOSE 1 X 402.00	1
H178	1/2 FUEL LINE	6'
H177	3/8 FUEL LINE	7'

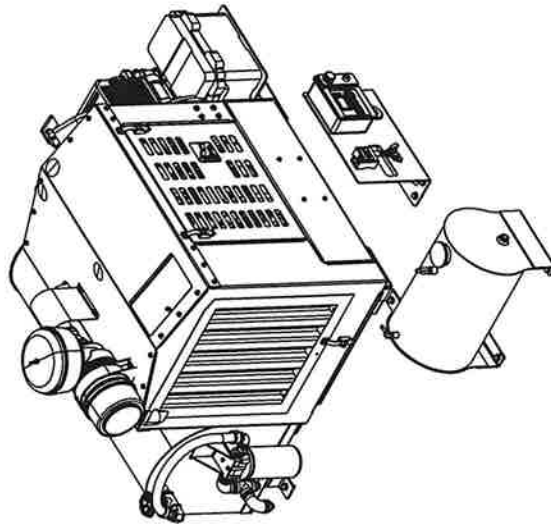

CAT 88 HP ENGINE SKID ENGINE SKID DETAIL

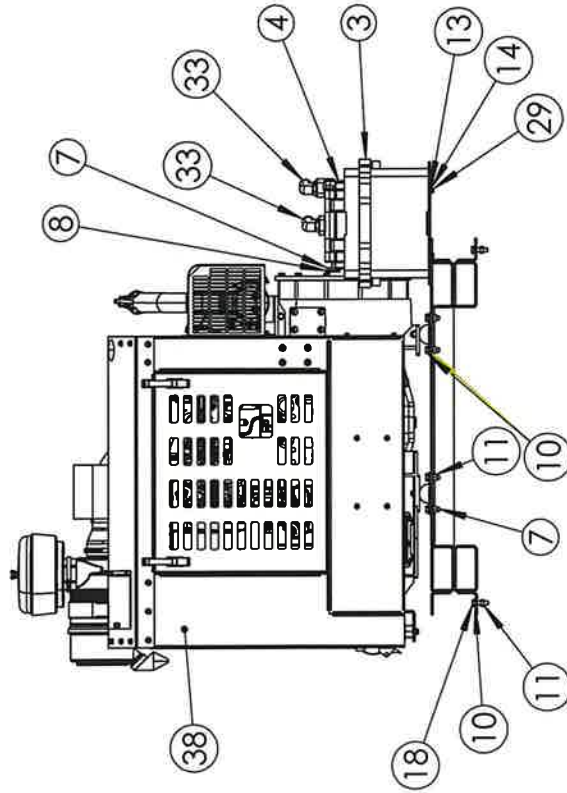
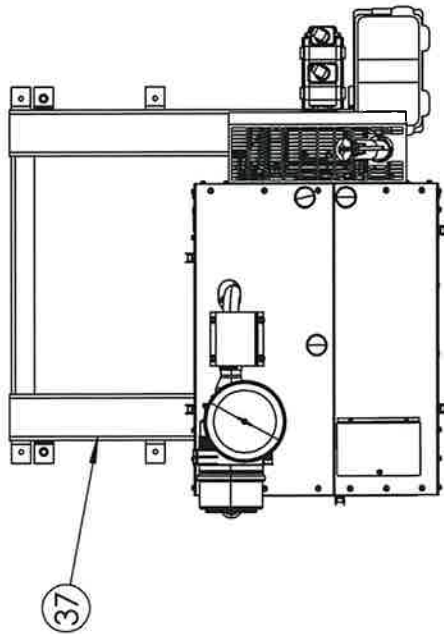

ITEM NO.	PART NUMBER	DESCRIPTION	QTY.
3	01353	BATTERY BOX W/ LID	1
4	1054947	HYDRAULIC PUMP	1
7	18057426	BOLT, HX CAP 1/2-13 X 1 1/2 LG	12
8	18891400	WASHER, 1/2 LOCK ZC	4
10	18811400	WASHER, FLAT 1/2 ZC	20
11	18457650	NUT CTR LOCK 1/2 ZP ZC	12
12	18706421	BOLT, HX CAP 5/16-18 X 3/4 LG SS	4
13	18991100	WASHER, FLAT 5/16 SS	8
14	18991110	WASHER, LOCK 5/16 SS	4
18	18057428	BOLT HX CAP 1/2-13 X 1 3/4 ZC	4
29	18987700	NUT 5/16 SERR FLG	4
30	6408-20	#20 O-RING PLUG	1
33	6801-12-16	FITTING ELBOW #12 JIC O-RING	2
34	4601-24-20	HOSEBARB 90	1
37	70536	ENGINE SKID, PERKINS/CAT	1
38	393-3430	CAT 88 HP POWER UNIT	1

CAT 88 HP ENGINE SKID CONTROL PANEL DETAIL

ITEM NO.	PART NUMBER	DESCRIPTION	QTY.
15	18475240	BOLT HX CAP 1/2-13 X 1 1/4 LG SS	4
16	18824800	WASHER FLAT 1/2 SS	8
17	18567400	NUT SS NYLOCK 1/2	4
39	71017	CONTROL BOX WELDT	1
40	GROMMET	GROMMET	1
41	TEC-10 CONTROLLER	CAT CONTROL BOX (INCLUDED WITH POWER UNIT)	1
42	AGRICOVER CONTROL	AGRICOVER CONTROL	1
43	18566400	NUT SS NYLOCK 3/8	2
44	18176450	BOLT, CARRIAGE, 3/8-16 X 1	2

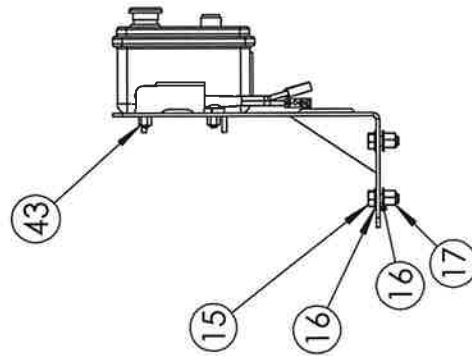
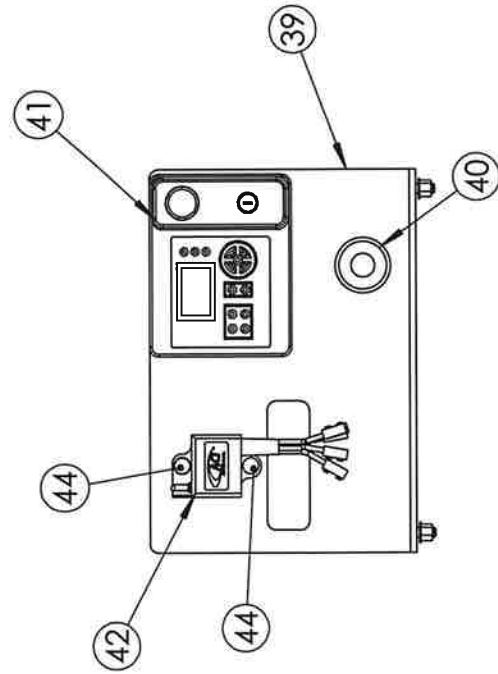
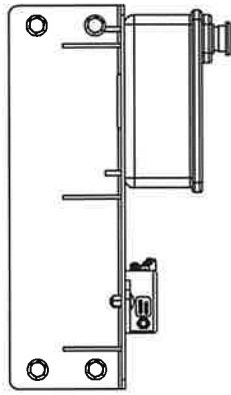

CAT 88 HP ENGINE SKID FUEL TANK DETAIL

ITEM NO.	PART NUMBER	DESCRIPTION	QTY.
1	71082	FUEL TANK 14 GALLON, T4	1
6	60001	FUEL TANK CAP	1
15	18475240	BOLT HX CAP 1/2-13 X 1 1/4 LG SS	4
16	18824800	WASHER FLAT 1/2 SS	8
17	18567400	NUT SS NYLOCK 1/2	4
28	1091809	FLUID LEVEL SIGHT GLASS	1
35	72220	DRAIN PLUG 3/4 NPT	1
45	71088	ADAPTER ELBOW, 1/2 HOSE, 1/2 NPT MALE	1
46	71089	ADAPTER ELBOW, 3/8 HOSE, 3/8 NPT MALE	1

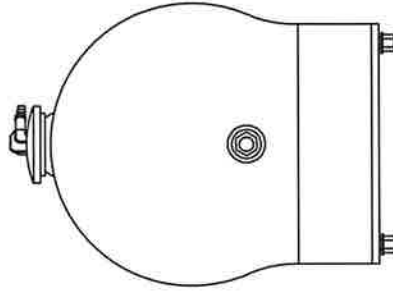
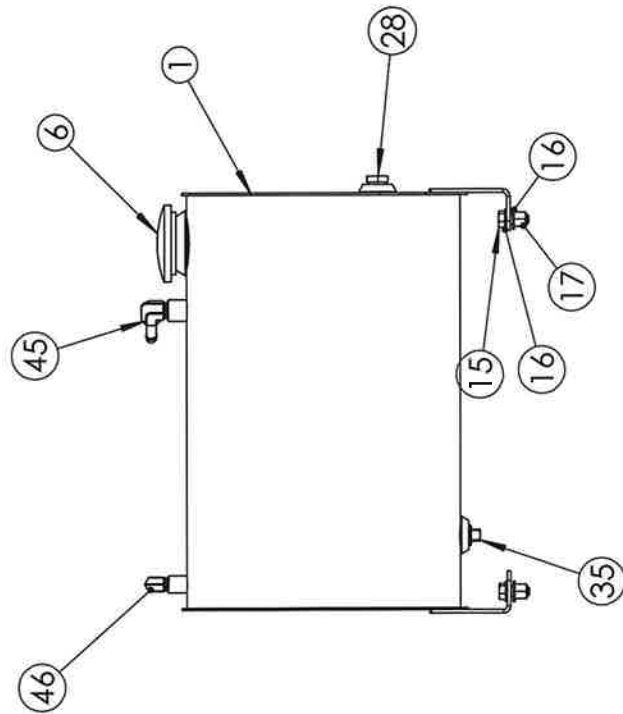

CAT 88 HP ENGINE SKID OIL TANK DETAIL

ITEM NO.	PART NUMBER	DESCRIPTION	QTY.
2	48300310	58 GALLON OIL TANK	1
5	48300330	DIP STICK	1
7	18057426	BOLT, HX CAP 1/2-13 X 1 1/2 LG	4
8	18891400	WASHER, 1/2 LOCK ZC	4
9	18417400	NUT, HX 1/2 NC ZC	4
10	18811400	WASHER, FLAT 1/2 ZC	4
19	SE25	OIL FILTER ELEMENT 10 MIL	1
20	20239	OIL FILTER HEAD 1 1/4 NPT	1
21	72330	CLOSE NIPPLE 1 1/4" NPT	1
22	72355	1 1/4 STREET ELBOW	2
23	72342	PIPE TEE 1 1/4 NPT	1
24	72390	CLOSE NIPPLE 1 1/2	1
25	51497	GATE VALVE 1 1/2 NPT	1
26	4501-24-24	1 1/2 HOSE ADAPTER	1
27	02006	1 1/4" GATE VALVE	1
31	2404-16-20	ADAPTER 1 1/4 NPT M X #16 JIC M	2
32	2404-12-20	ADAPTER 1 1/4 MNPT X #12 MJIC	1
35	72220	DRAIN PLUG 3/4 NPT	1
36	1044762	2" X 1 1/2" EXTERNALLY MOUNTED STRAINER W/ BYPASS	1
47	71103	19" HOSE WITH FITTINGS	1
48	2024-20-16	20 NPTM-16 JIC ELBOW	1
49	18026422	BOLT CAP SS 5/16 X 1	2

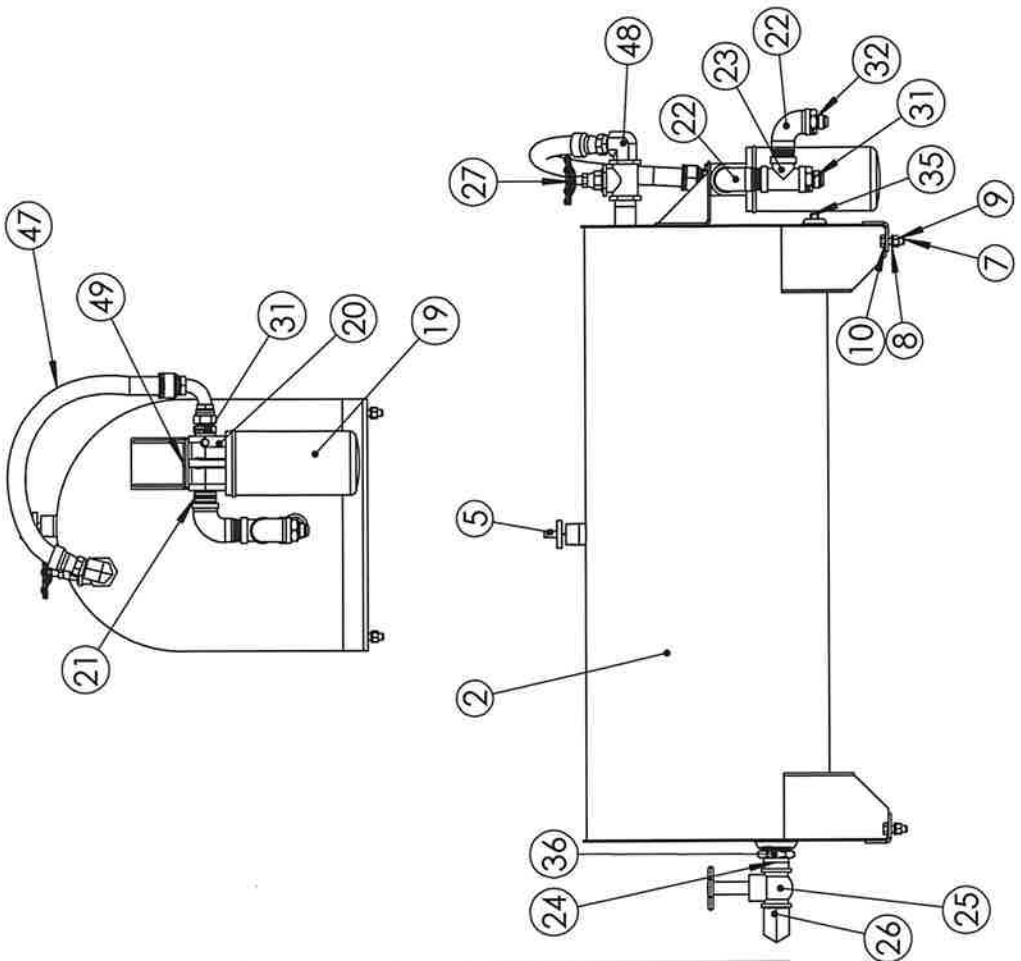

MUFFLER EXTENSION KIT
 FOR CAT 88 HP ENGINE (IF REQUIRED)
 P/N: 71118

ITEM NO.	PART NUMBER	DESCRIPTION	QTY.
1	735-1679	EXHAUST ELBOW 2 1/2 90 DEGREE	1
2	7335979	EXHAUST CLAMP	1
3	703-1504	EXHAUST WEATHER CAP	1

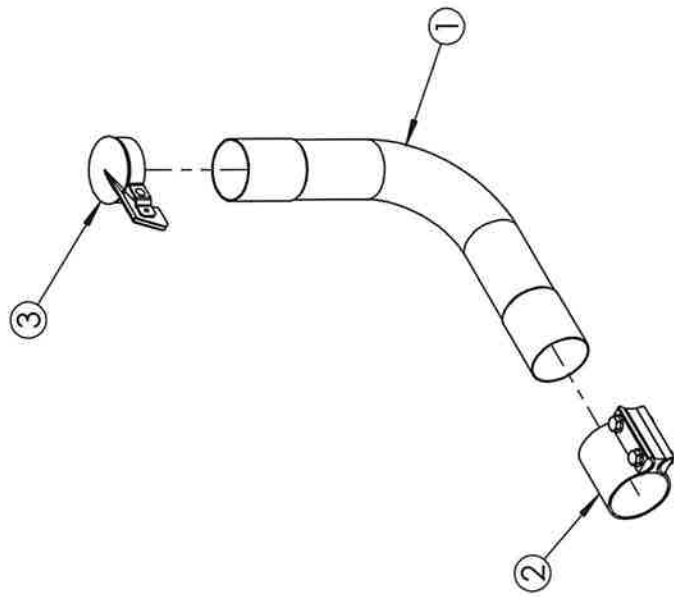

76-CAT

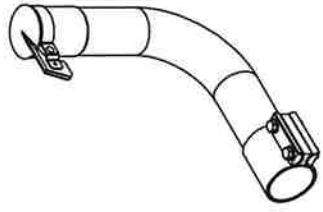

DEUTZ 74.2 HP ENGINE SKID

ILLUSTRATION

PART #: 48300385
2021 AND BEYOND

BILL OF MATERIAL - SHEETS 70&71 DEUTZ
ENGINE SKID DETAIL - SHEET 72 DEUTZ
CONTROL PANEL DETAIL - SHEET 73 DEUTZ
FUEL TANK DETAIL - SHEET 74 DEUTZ
OIL TANK DETAIL - SHEET 75 DEUTZ

69-DEUTZ

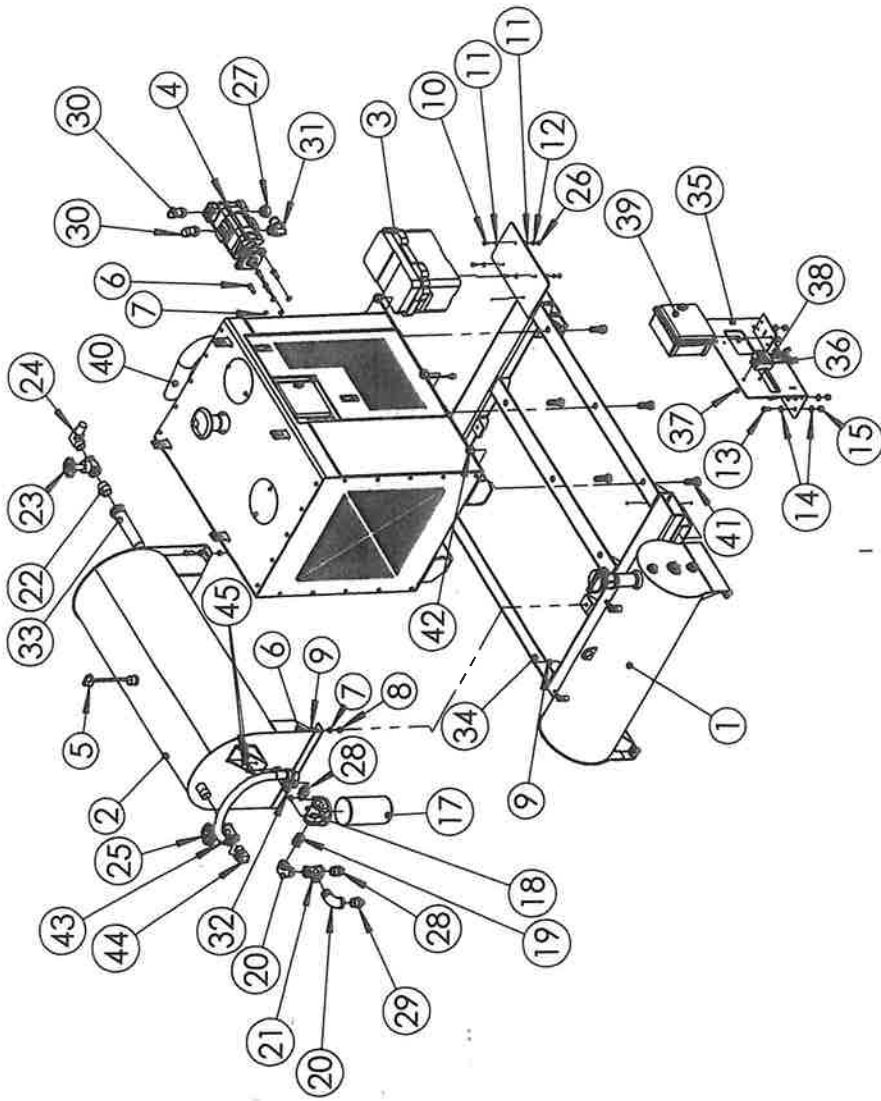

EXPLODED VIEW

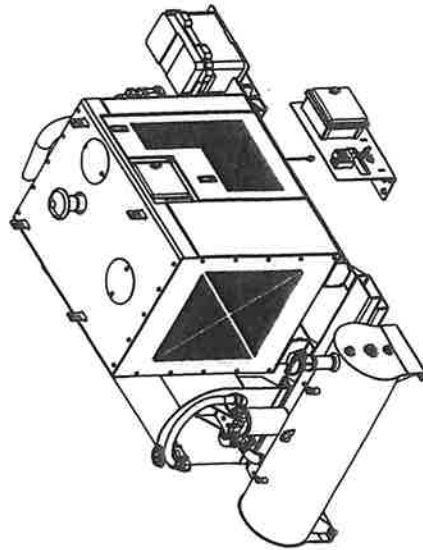

NORMAL VIEW

DEUTZ 74.2 HP ENGINE SKID

BILL OF MATERIAL - PART #: 48300385

BOM Table			
ITEM NO.	PART NUMBER	DESCRIPTION	QTY.
1	48300310	58 GALLON OIL TANK	1
2	71638	28 GALLON FUEL TANK, T4	1
3	01353	BATTERY BOX W/ LID	1
4	MT900TAPUMP	HYDRAULIC PUMP	1
5	48300330	DIP STICK	1
6	18057426	BOLT, HX CAP 1/2-13 X 1 1/2 LG	8
7	18891400	WASHER, 1/2 LOCK ZC	8
8	18417400	NUT, HX 1/2 NC ZC	4
9	18811400	WASHER, FLAT 1/2 ZC	8
10	18706421	BOLT, HX CAP 5/16-18 X 3/4 LG SS	3
11	18991100	WASHER, FLAT 5/16 SS	6
12	18991110	WASHER, LOCK 5/16 SS	3
13	18475240	BOLT HX CAP 1/2-13 X 1 1/4 LG SS	4
14	18824800	WASHER FLAT 1/2 SS	8
15	18567400	NUT SS NYLOCK 1/2	4
16	18457650	NUT CTR LOCK 1/2 ZP ZC	4
17	SE25	OIL FILTER ELEMENT 10 MIL	1
18	20239	OIL FILTER HEAD 1 1/4 NPT	1
19	72330	CLOSE NIPPLE 1 1/4" NPT	1
20	72355	1 1/4 STREET ELBOW	2
21	72342	PIPE TEE 1 1/4 NPT	1
22	72390	CLOSE NIPPLE 1 1/2	1
23	51497	GATE VALVE 1 1/2 NPT	1
24	4501-24-24	1 1/2 HOSE ADAPTER	1
25	02006	1 1/4" GATE VALVE	1
26	18987700	NUT 5/16 SERR FLG	3
27	6408-20	#20 O-RING PLUG	1

BOM Table			
ITEM NO.	PART NUMBER	DESCRIPTION	QTY.
28	2404-16-20	ADAPTER 1 1/4 NPT M X #16 JIC M	2
29	2404-12-20	ADAPTER 1 1/4 MNPT X #12 MJIC	1
30	6801-12-16	ELBOW 90 DEG #12 MJIC X #16 MORB	2
31	4601-24-20	BEADED HOSE TO ORING ELBOW 90	1
32	72220	DRAIN PLUG 3/4 NPT	1
33	1044762	2" X 1 1/2" EXTERNALLY MOUNTED STRAINER W/ BYPASS	1
34	71021	ENGINE SKID, DEUTZ T4	1
35	71024	CONTROL BOX WELDT	1
36	AGRICOVER CONTROL	AGRICOVER CONTROL (INCLUDED WITH TARP)	1
37	18566400	NUT SS NYLOCK 3/8	2
38	18176450	BOLT, CARRIAGE, 3/8-16 X 1	2
39	303264	CONTROL BOX	1
40	47995366	DEUTZ ENGINE	1
41	18058313	BOLT GR8 7/8-9 X 2 1/2 LG ZC YELLOW	6
42	18458454	NUT NYLOCK GR 8 7/8-9 ZC YELLOW	6
43	71103	19" HOSE WITH FITTINGS	1
44	2024-20-16	20 NPTM-16 JIC elbow	1
45	18026422	BOLT CAP SS 5/16 X 1	2
46	71627	DIE SPRING, 1 X 1.5, BLUE	2
47	18057438	BOLT, 1/2-13 X 3 GR5 ZP	2
48	18057428	BOLT HX CAP 1/2-13 X 1 3/4 ZC	2

NOTES:

1. THE AGRICOVER CONTROL IS INCLUDED WITH THE ROLL TARP KIT
2. THE 303264 CONTROL BOX IS INCLUDED WITH ENGINE

ITEMS ALSO INCLUDED BUT NOT SHOWN

PART NUMBER	DESCRIPTION	QTY
FBA12684100	FUEL LINE CLIPS	8
FBA12683100	HOSE LINE CLAMPS	2
12003501	SUCTION HOSE	1
71092	2 GA BATTERY CABLE 48" RED	1
71093	2 GA BATTERY CABLE 38" BLACK	1
31-7237	GROUP 27 BATTERY	1
4050	HYDRAULIC OIL	56
H178	1/2 FUEL LINE	6'
H177	3/8 FUEL LINE	7'
43082316	SUCTION HOSE CLAMPS	2

OIL DRAIN KIT AND 8' HARNESS EXTENSION ARE INCLUDED WITH POWER UNIT.

DEUTZ 74.2 HP ENGINE SKID ENGINE SKID DETAIL

ITEM NO.	PART NUMBER	DESCRIPTION	QTY.
3	01353	BATTERY BOX W/ LID	1
4	MT900TAPUMP	HYDRAULIC PUMP	1
6	18057426	BOLT, HX CAP 1/2-13 X 1 1/2 LG	4
7	18891400	WASHER, 1/2 LOCK ZC	4
9	18811400	WASHER, FLAT 1/2 ZC	4
10	18706421	BOLT, HX CAP 5/16-18 X 3/4 LG SS	3
11	18991100	WASHER, FLAT 5/16 SS	6
12	18991110	WASHER, LOCK 5/16 SS	3
16	18457650	NUT CTR LOCK 1/2 ZP ZC	4
26	18987700	NUT 5/16 SERR FLG	3
27	6408-20	#20 O-RING PLUG	1
30	6801-12-16	ELBOW 90 DEG #12 MJIC X #16 MORB	2
31	4601-24-20	BEADED HOSE TO ORING ELBOW 90	1
34	71021	ENGINE SKID, DEUTZ T4	1
40	47995366	DEUTZ ENGINE	1
41	18058313	BOLT GR8 7/8-9 X 2 1/2 LG ZC YELLOW	6
42	18458454	NUT NYLOCK GR 8 7/8-9 ZC YELLOW	6
46	71627	DIE SPRING, 1 X 1.5, BLUE	2
47	18057438	BOLT, 1/2-13 X 3 GR5 ZP	2
48	18057428	BOLT HX CAP 1/2-13 X 1 3/4 ZC	2

ASSEMBLY NOTE:
71627 DIE SPRINGS LOCATED ON FRONT MOUNTS
TIGHTEN TO COMPRESSED LENGTH OF 1.125"

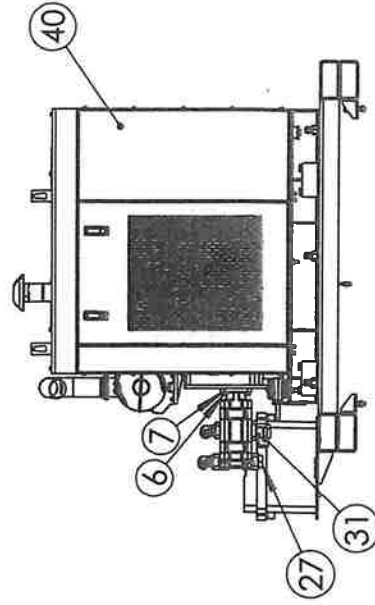
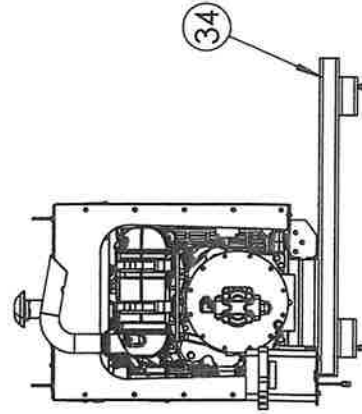
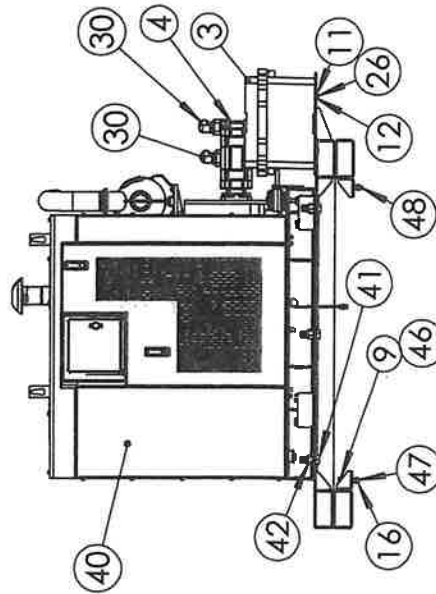

DEUTZ 74.2 HP ENGINE SKID CONTROL PANEL DETAIL

ITEM NO.	PART NUMBER	DESCRIPTION	QTY.
13	18475240	BOLT HX CAP 1/2-13 X 1 1/4 LG SS	4
14	18824800	WASHER FLAT 1/2 SS	8
15	18567400	NUT SS NYLOCK 1/2	4
35	71024	CONTROL BOX WELDT	1
36	AGRICOVER CONTROL	AGRICOVER CONTROL (INCLUDED WITH TARP)	1
37	18566400	NUT SS NYLOCK 3/8	2
38	18176450	BOLT, CARRIAGE, 3/8-16 X 1	2
39	303264	CONTROL BOX	1

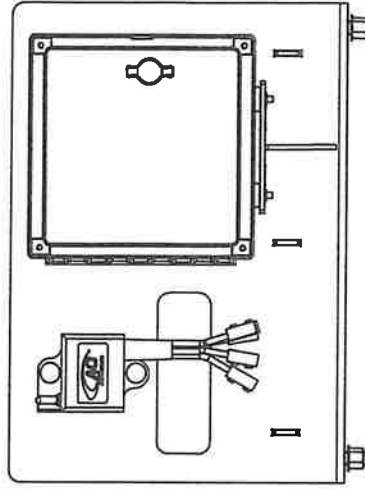
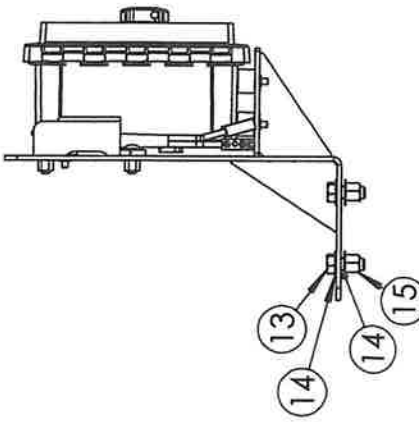
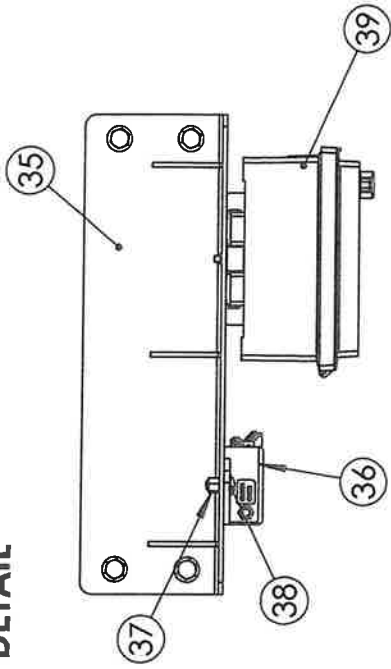

DEUTZ 74.2 HP ENGINE SKID

FUEL TANK DETAIL

14 GALLON
PART NUMBER: 71718
(PRIOR TO FALL 2023)

(MT900TA UP TO S/N 1119)
(VPA1000 UP TO S/N 1015)

ITEM NO.	PART NUMBER	DESCRIPTION	QTY.
1	71082	FUEL TANK 14 GALLON, T4	1
2	18475240	BOLT HX CAP 1/2-13 X 1 1/4 LG SS	4
3	18824800	WASHER FLAT 1/2 SS	8
4	18567400	NUT SS NYLOCK 1/2	4
5	1091809	FLUID LEVEL SIGHT GLASS	1
6	72220	DRAIN PLUG 3/4 NPT	1
7	71088	ADAPTER ELBOW, 1/2 HOSE, 1/2 NPT MALE	1
8	71089	ADAPTER ELBOW, 3/8 HOSE, 3/8 NPT MALE	1
9	71631	FILLER PIPE WITH BAFFLE	1
10	60002	CAP PREVENT CASTING AND FILL CAP	1
11	71761	WIRE LOCK CLEVIS PIN W/ LOOP 3/8 DIA 2 LG	1

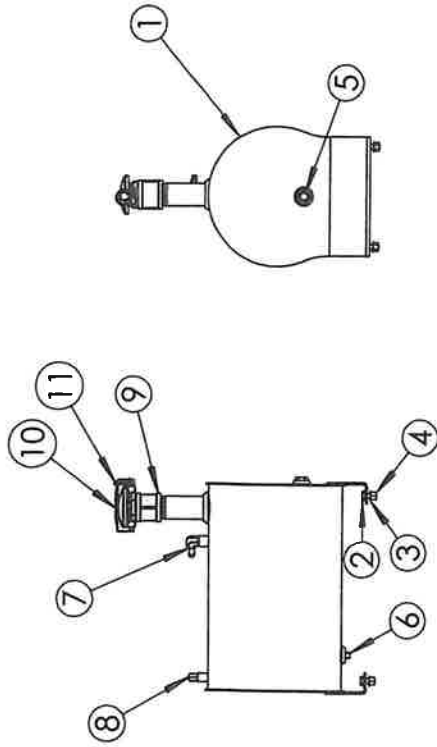

28 GALLON
PART NUMBER: 71638
(FALL 2023 AND BEYOND)

(MT900TA S/N 1120 AND BEYOND)
(VPA1000 S/N 1016 AND BEYOND)

ITEM NO.	PART NUMBER	DESCRIPTION	QTY.
1	71633	FUEL TANK 28 GALLON, T4	1
2	71631	FILLER PIPE WITH BAFFLE	1
3	1091809	FLUID LEVEL SIGHT GLASS	2
4	72220	DRAIN PLUG 3/4 NPT	1
5	71088	ADAPTER ELBOW, 1/2 HOSE, 1/2 NPT MALE	1
6	71089	ADAPTER ELBOW, 3/8 HOSE, 3/8 NPT MALE	1
7	71639	FUEL LEVEL GAUGE	1
8	18475240	BOLT HX CAP 1/2-13 X 1 1/4 LG SS	4
9	18567400	NUT SS NYLOCK 1/2	4
10	18824800	WASHER FLAT 1/2 SS	8
11	60002	CAP PREVENT CASTING AND FILL CAP	1
12	71761	WIRE LOCK CLEVIS PIN W/ LOOP 3/8 DIA 2 LG	1

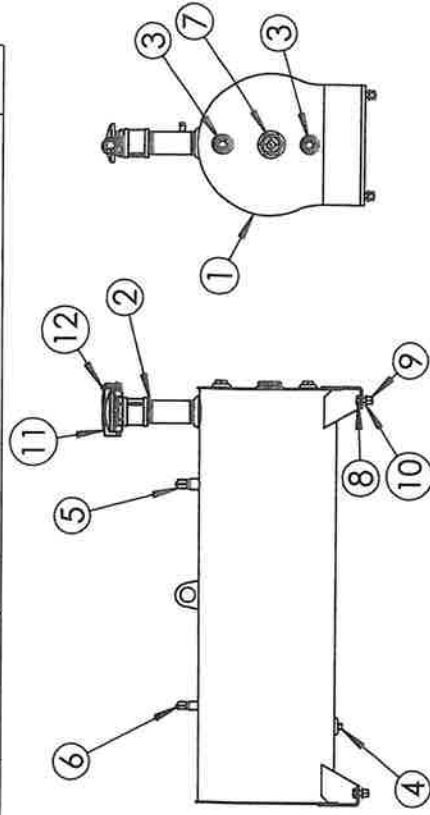

NOTE: APPLY THREAD SEALANT TO ALL THREADED FITTINGS

DEUTZ 74.2 HP ENGINE SKID OIL TANK DETAIL

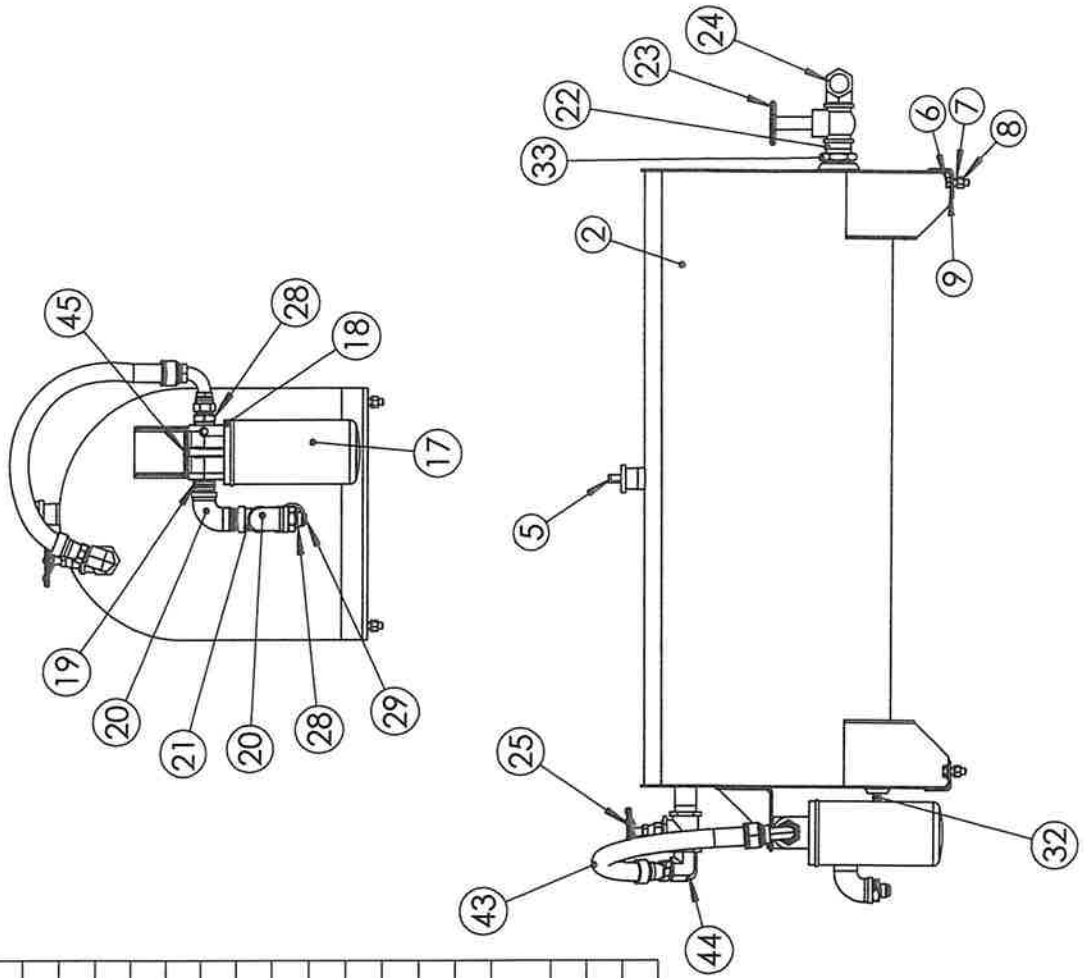

ITEM NO.	PART NUMBER	DESCRIPTION	QTY.
2	48300310	58 GALLON OIL TANK	1
5	48300330	DIP STICK	1
6	18057426	BOLT, HX CAP 1/2-13 X 1 1/2 LG	4
7	18891400	WASHER, 1/2 LOCK ZC	4
8	18417400	NUT, HX 1/2 NC ZC	4
9	18811400	WASHER, FLAT 1/2 ZC	4
17	SE25	OIL FILTER ELEMENT 10 MIL	1
18	20239	OIL FILTER HEAD 1 1/4 NPT	1
19	72330	CLOSE NIPPLE 1 1/4" NPT	1
20	72355	1 1/4 STREET ELBOW	2
21	72342	PIPE TEE 1 1/4 NPT	1
22	72390	CLOSE NIPPLE 1 1/2	1
23	51497	GATE VALVE 1 1/2 NPT	1
24	4501-24-24	1 1/2 HOSE ADAPTER	1
25	02006	1 1/4" GATE VALVE	1
28	2404-16-20	ADAPTER 1 1/4 NPT M X #16 JIC M	2
29	2404-12-20	ADAPTER 1 1/4 MNPT X #12 MJIC	1
32	72220	DRAIN PLUG 3/4 NPT	1
33	1044762	2" X 1 1/2" EXTERNALLY MOUNTED STRAINER W/ BYPASS	1
43	71103	19" HOSE WITH FITTINGS	1
44	2024-20-16	20 NPTM-16 JIC ELBOW	1
45	18026422	BOLT CAP SS 5/16 X 1	2

THIS PAGE LEFT
BLANK INTENTIONALLY

TRUCK MOUNTED TENDER OIL TANK LAYOUT

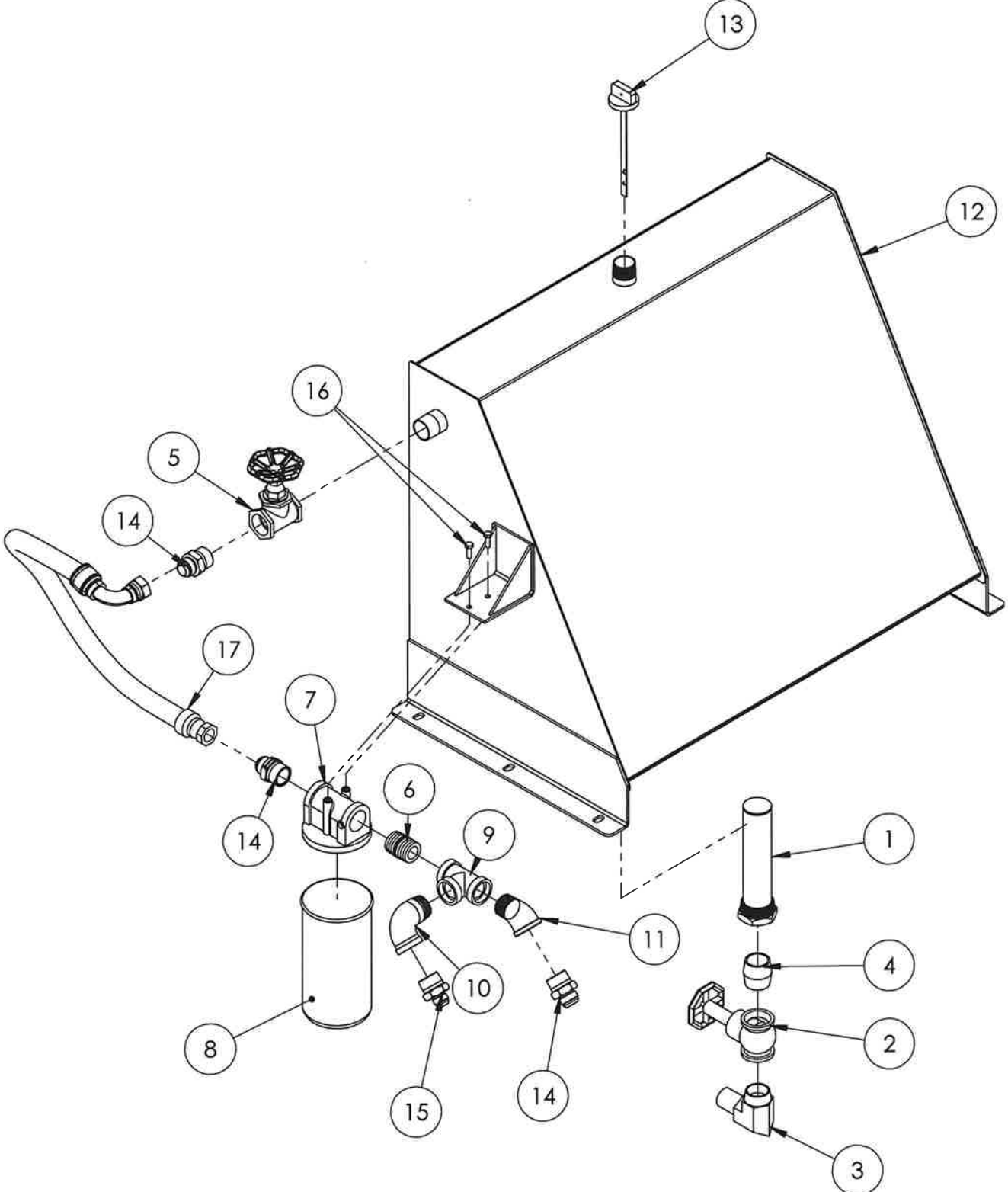

TRUCK MOUNTED TENDER OIL TANK

PARTS LIST

P/N : 47976641

ITEM NO.	PART NUMBER	DESCRIPTION	Default/ QTY.
1	1044762	2" X 1 1/2" EXTERNALLY MOUNTED STRAINER W/ BYPASS	1
2	51497	GATE VALVE 1 1/2 NPT	1
3	4501-24-24	1 1/2 HOSE ADAPTER	1
4	72390	CLOSE NIPPLE 1 1/2	1
5	02006	1 1/4" GATE VALVE	1
6	72330	CLOSE NIPPLE 1 1/4" NPT	1
7	20239	OIL FILTER HEAD 1 1/4 NPT	1
8	SE25	OIL FILTER ELEMENT 10 MIL	1
9	72342	PIPE TEE 1 1/4 NPT	1
10	72355	1 1/4 STREET ELBOW	1
11	72343	ELBOW, 1 1/4 X 45 DEG STREET	1
12	47076641	MT900/MT600 OIL TANK 57 GAL	1
13	48300330	DIP STICK	1
14	2404-16-20	ADAPTER 1 1/4 NPT M X #16 JIC M	3
15	2404-12-20	ADAPTER 1 1/4 MNPT X #12 MJIC	1
16	18026422	BOLT CAP SS 5/16 X 1	2
17	71103	19" HOSE WITH FITTINGS	1
18	18824800	WASHER FLAT 1/2 SS	2

ALSO REQ'D BUT NOT SHOWN:

QTY	PART NUMBER	DESCRIPTION
6	18022026	BOLT SS HX 1/2 X 1 1/2
6	18567400	NUT NYLOCK 1/2 SS
12	18824800	WASHER FLAT 1/2 SS

MT900 GREASE BANK SETUP SHEET

MT900GZSS
04/27/21

HOSE KIT P/N:
1128223

DETAIL A-A

DETAIL C
ROTATED 90°

DECAL #76708
VERT. AUGER SUPPORT
2 PUMPS EVERY 75 HRS.

DECAL #76706
AUGER BEARINGS
1 SHOT EVERY 75 HRS

DECAL #76707
2 BOTTOM ZERKS/
1 SHOT EVERY 75 HRS.

DETAIL B
SCALE 1 : 8

GW102R
GW100R
GW104R
GW114R
GW60R TO LOWER AUGER
LOWER FLANGE BEARING
GW296R TO LOWER AUGER
FRONT BEARING

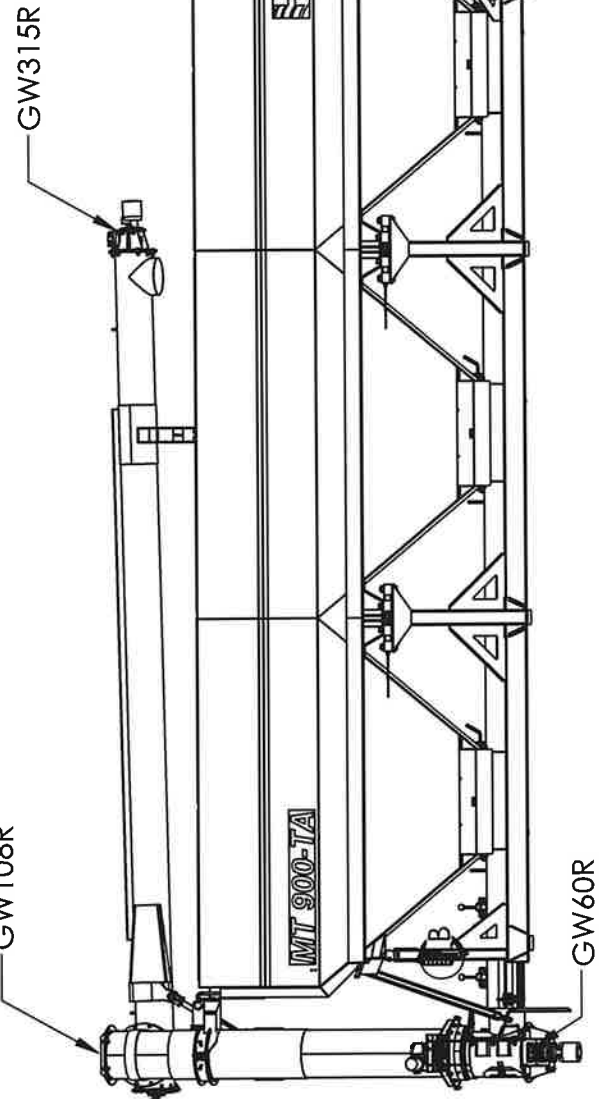
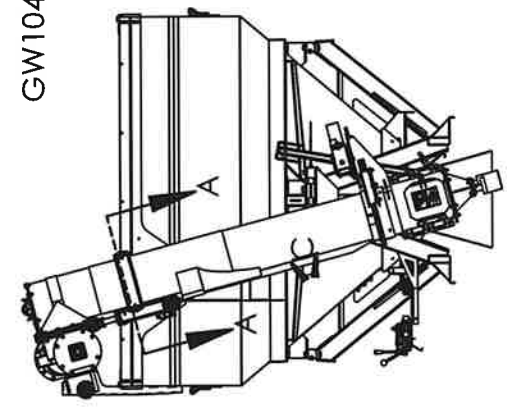
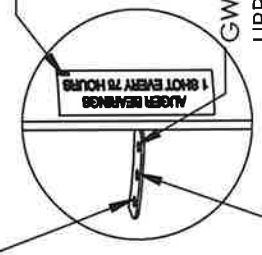
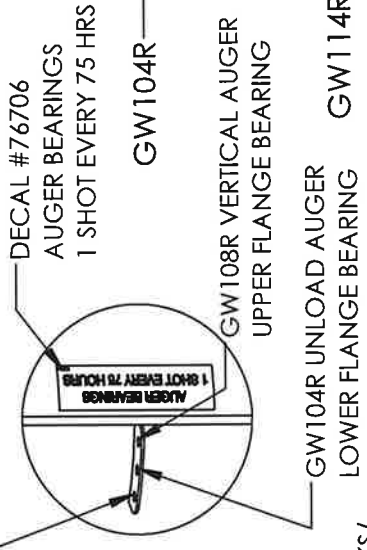
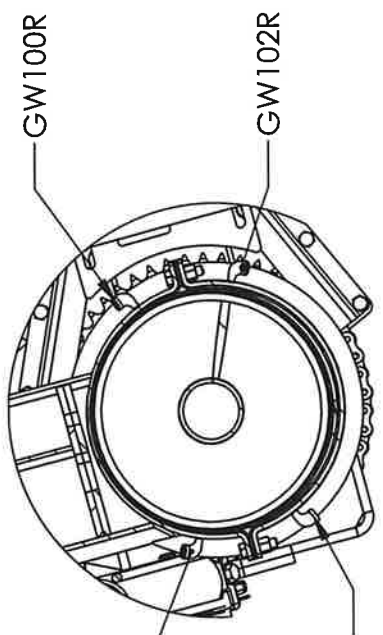

MT600 GREASE BANK SETUP SHEET

MT600GZSS
04/27/21

HOSE KIT P/N:
1129713

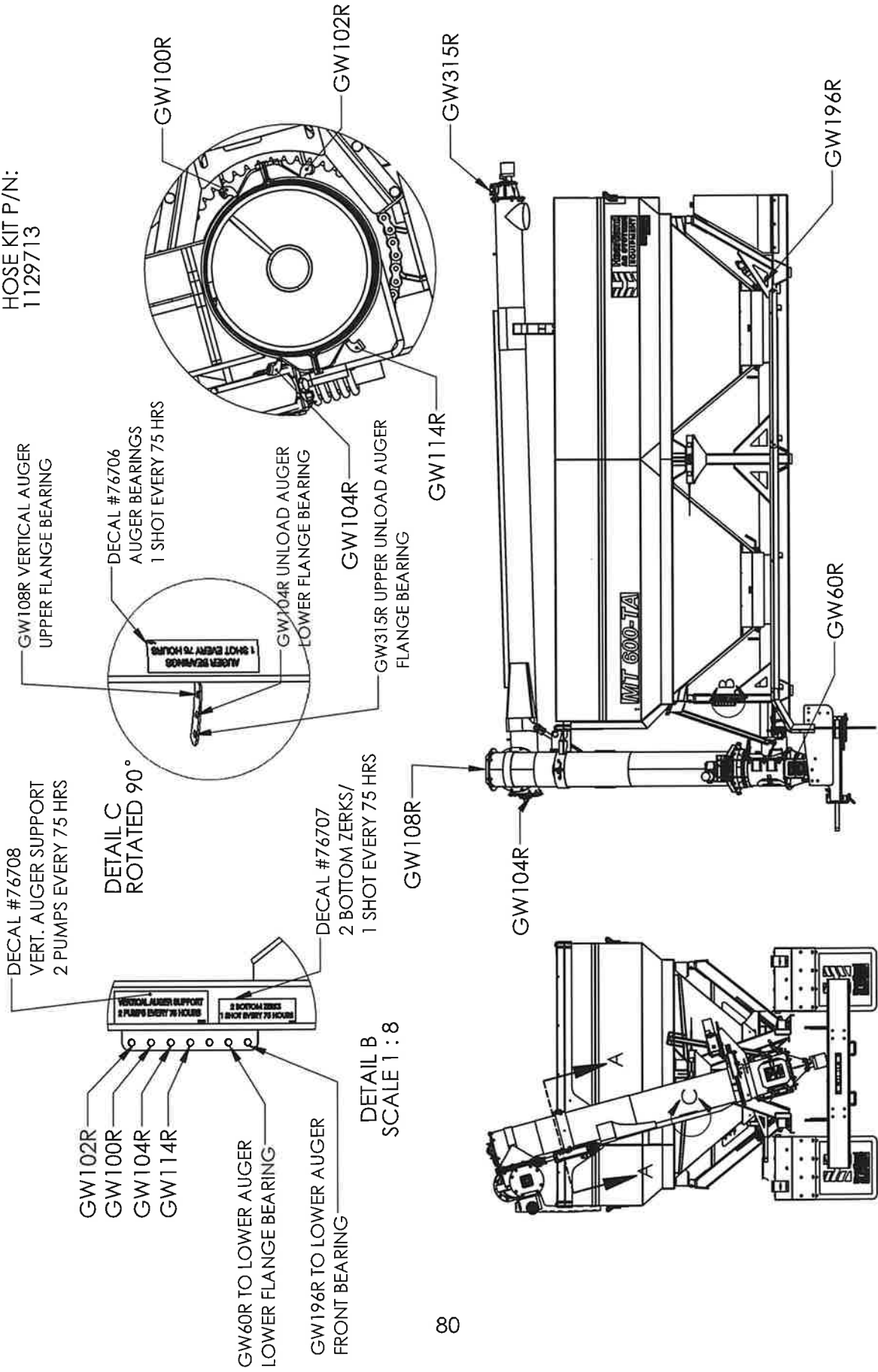

MT900 TRAILER MOUNT DECAL LOCATIONS

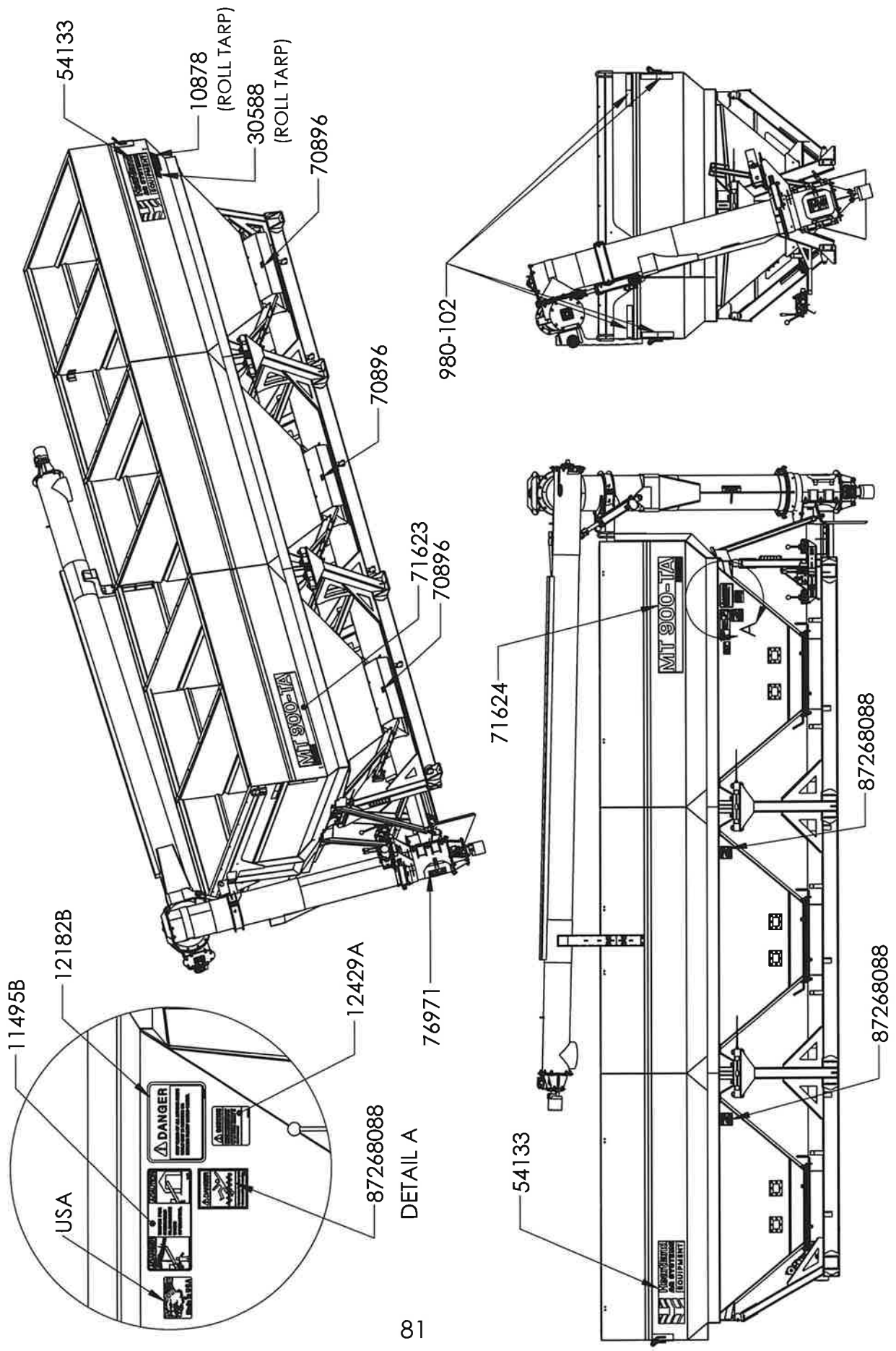

MT900 DECALS

(KIT P/N: MT900DECALS)

PART NUMBER	QTY	DESCRIPTION
11495B	1	WATCH FOR OVERHEAD CLEARANCE CAUTION
76971	1	DO NOT OPEN DOORS WHILE RUNNING
12182B	1	DANGER, STAY CLEAR OF MOVING PARTS
12429A	1	CAUTION READ SERVICE MANUAL
71624	1	MT900TA (DRIVER)
71623	1	MT900TA (DITCH)
54133	2	HEARTLAND AG SYSTEMS DECAL
87268088	3	DANGER DO NOT ENTER FERTILIZER TANK
276534	1	HYDRAULIC OIL
76768	3	ARROW DECAL
USA	1	MADE IN USA
76706	1	AUGER BEARINGS 1 SHOT EVERY 75 HRS
76707	1	2 BOTTOM ZERKS / 1 SHOT EVERY 75 HRS
76708	1	VERTICAL AUGER SUPPORT 2 PUMPS EVERY 75 HRS
70896	3	DANGER, PINCH POINT
980-102	4	REFLECTIVE TAPE WHITE 1'
<i>(INCLUDED WITH THE ROLL TARP)</i>		
10878	1	CAUTION AGRICOVER TENSION
30588	1	IMPORTANT ADJUSTMENT OF RATCHETS
60814	1	STOP UNLOAD W/ CLOSED TARP

11495B



76971



12182B



12429A

MT 900-TA

71624

MT 900-TA

71623



54133



87268088



276534



USA



76706



76707



76708



76768



70896

(INCLUDED WITH ROLL TARP)

10878

30588

60814

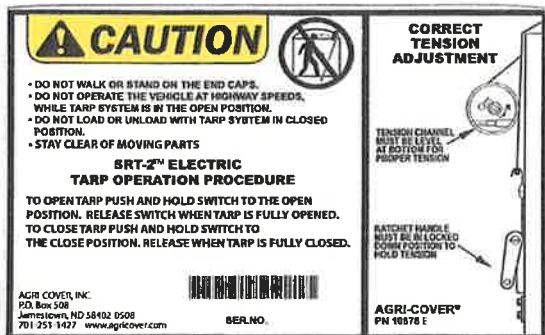

MT600/900 ROTATIONAL DECAL

APPLY THE DECALS AS SHOWN, WHEN THE HORIZONTAL UNLOAD AUGER IS RESTING IN THE CRADLE. THIS WILL ALLOW THE MONITORING OF THE HORIZONTAL UNLOAD AUGER ROTATION AND RETURN PATH. **ALWAYS WATCH THE UNLOAD AUGER WHEN LOWERING IT BACK INTO THE CRADLE**

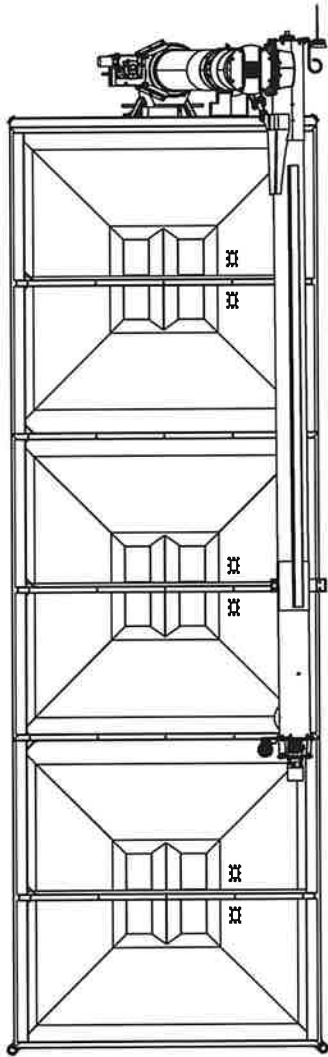

ARROW DECAL
P/N: 76768
(CRADLE POSITION)

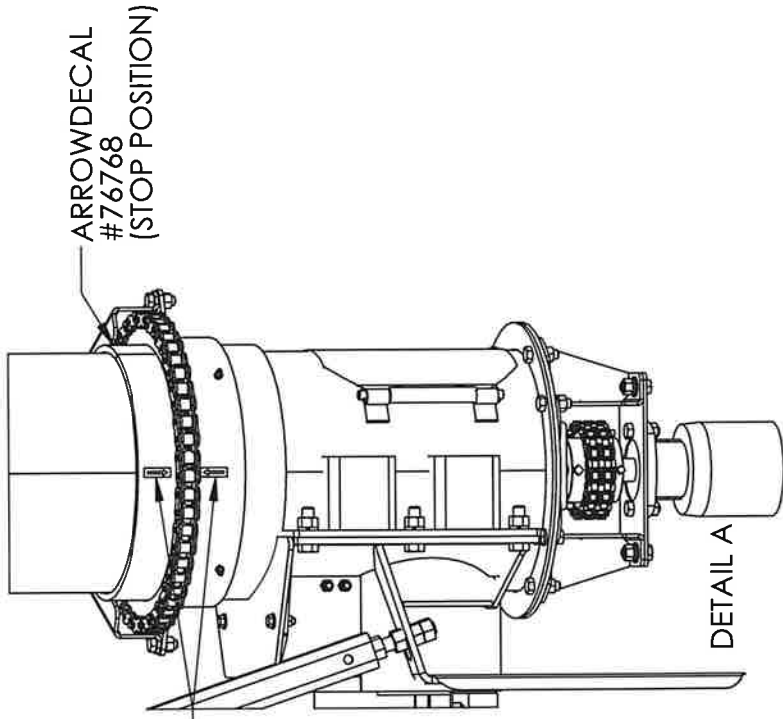
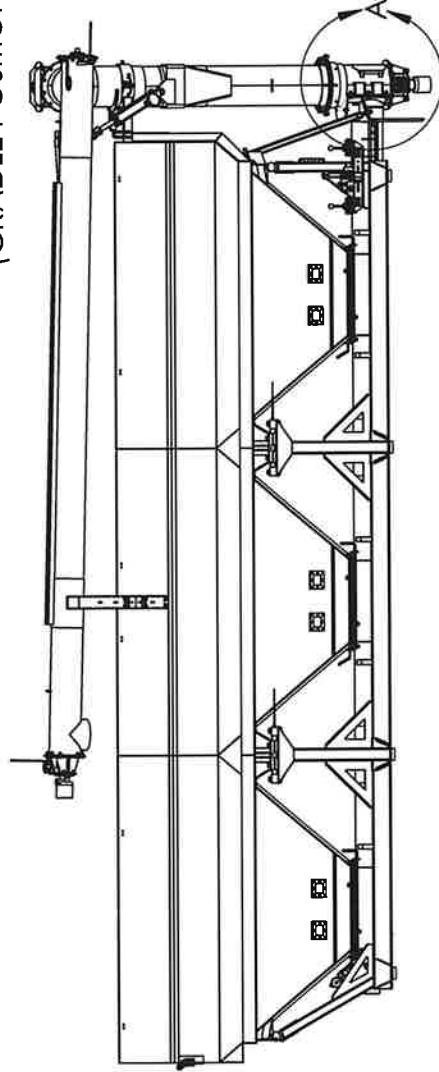

MT600 TRUCK MOUNT DECAL LOCATION

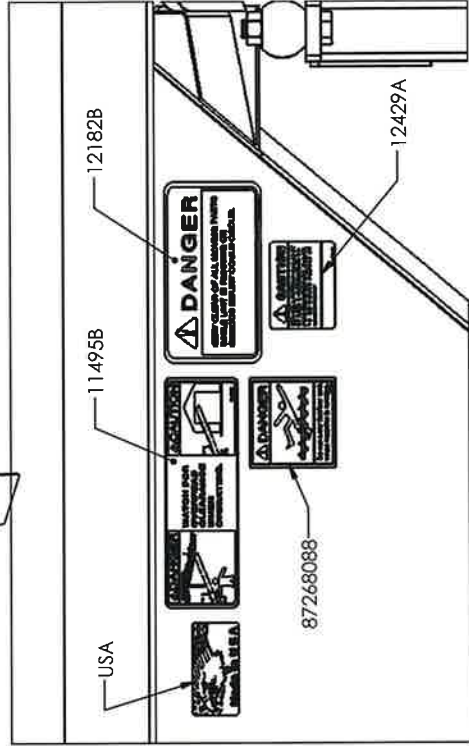
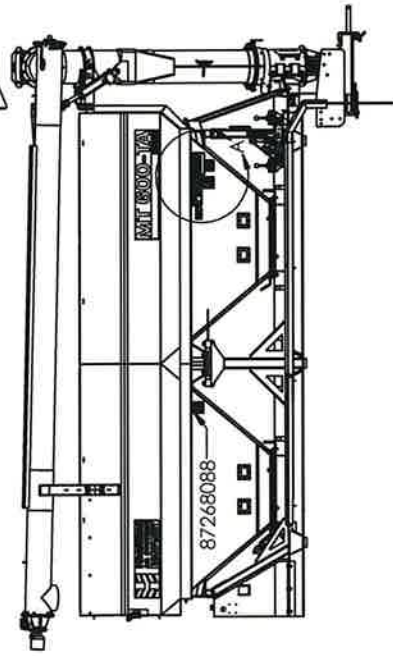
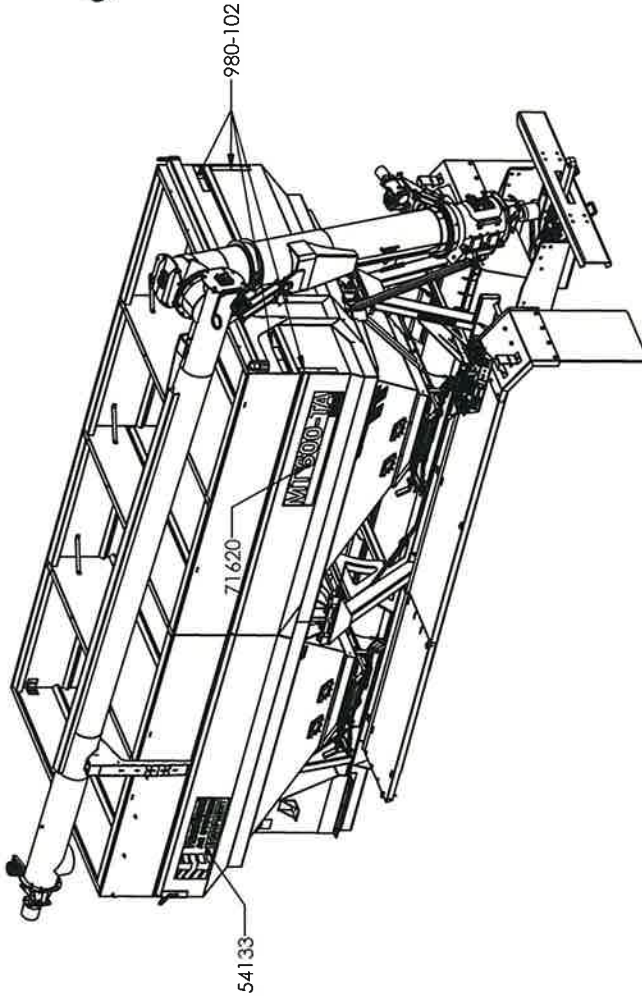
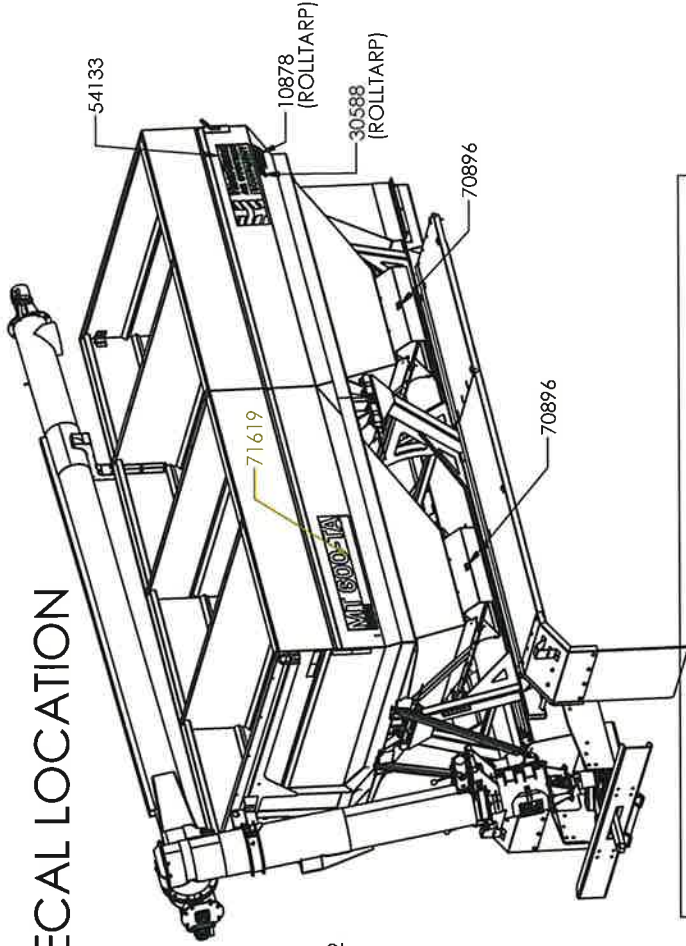

MT600 DECALS

(KIT P/N: MT600DECALS)

PART NUMBER	QTY	DESCRIPTION
11495B	1	WATCH FOR OVERHEAD CLEARANCE CAUTION
76971	1	DO NOT OPEN DOOR WHILE RUNNING
12182B	1	DANGER, STAY CLEAR OF MOVING PARTS
12429A	1	CAUTION READ SERVICE MANUAL
71620	1	MT600TA (DRIVER)
71619	1	MT600TA (DITCH)
54133	2	HEARTLAND AG SYSTEMS DECAL
87268088	2	DANGER DO NOT ENTER FERTILIZER TANK
276534	1	HYDRAULIC OIL
76768	3	ARROW DECAL
USA	1	MADE IN USA
76706	1	AUGER BEARINGS 1 SHOT EVERY 75 HRS
76707	1	2 BOTTOM ZERKS / 1 SHOT EVERY 75 HRS
76708	1	VERTICAL AUGER SUPPORT 2 PUMPS EVERY 75 HRS
70896	2	DANGER, PINCH POINT
980-102	4	REFLECTIVE TAPE WHITE 1'
<i>(INCLUDED WITH THE ROLL TARP)</i>		
10878	1	CAUTION AGRICOVER TENSION
30588	1	IMPORTANT ADJUSTMENT OF RATCHETS
60814	1	STOP UNLOAD W/ CLOSED TARP

11495B



76971



12182B



MT 600-TA MT 600-TA



12429A

71620

71619

54133



87268088



276534



USA



76706



76707



76708



76768



70896

(INCLUDED WITH ROLL TARP)

10878

30588

60814



MT600/900 ROTATIONAL DECAL

APPLY THE DECALS AS SHOWN, WHEN THE HORIZONTAL UNLOAD AUGER IS RESTING IN THE CRADLE. THIS WILL ALLOW THE MONITORING OF THE HORIZONTAL UNLOAD AUGER ROTATION AND RETURN PATH.

ALWAYS WATCH THE UNLOAD AUGER WHEN LOWERING IT BACK INTO THE CRADLE

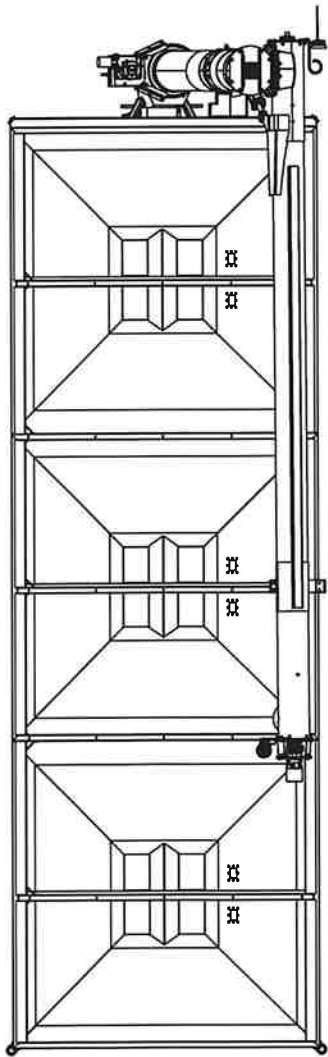

ARROW DECAL
P/N: 76768
(CRADLE POSITION)

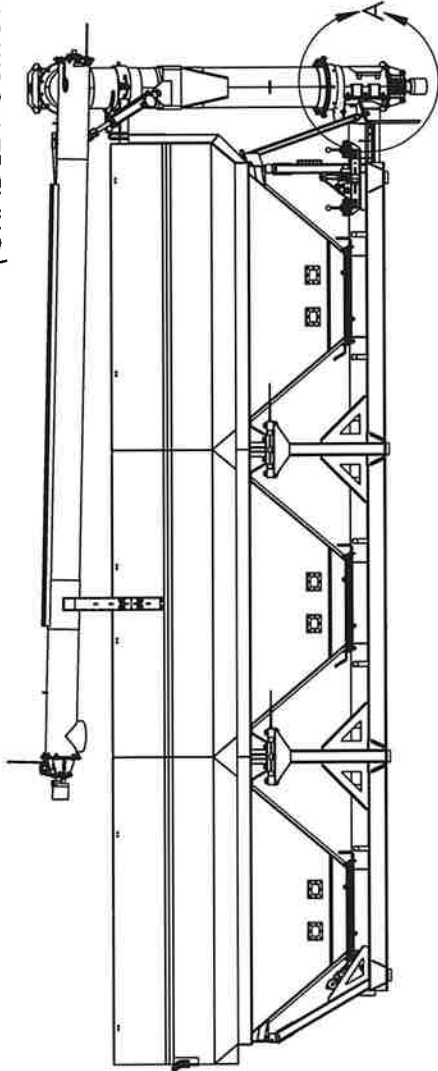

ARROWDECAL
#76768
(STOP POSITION)

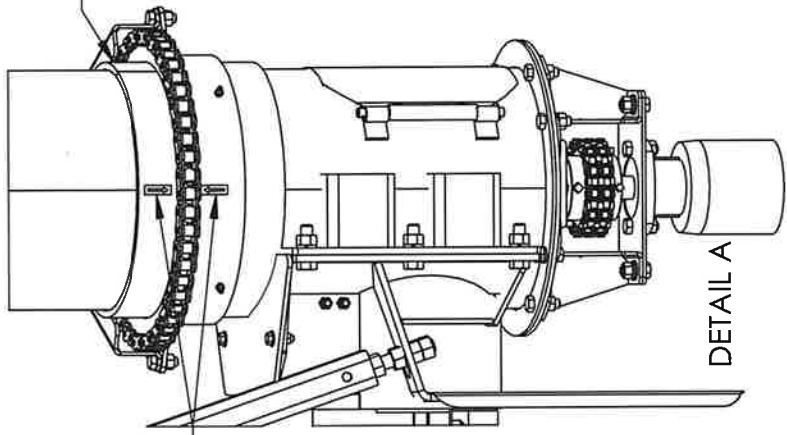

TA TRUCK TENDER LIGHT KIT

PART #: 71554

NOTE: FAR LED LIGHTS ON THE TRUCK NEEDS EITHER AN LED FLASHER, OR A 50 WATT 6 OHM RESISTOR ADDED TO THE WIRE HARNESS

ITEM NO.	PART NUMBER	DESCRIPTION	QTY.
1	M191-3RL	REAR LIGHTBAR	1
2	18104	CLEARANCE LIGHT AMBER	2
3	01829	TAIL LIGHT LH	1
4	01836	TAIL LIGHT RH	1
5	18026824	BOLT HX SS 3/8 X 1 1/4	2
6	18566400	NUT SS NYLOCK 3/8	2
7	18991200	WASHER FLAT 3/8 SS	4
8	18569200	NUT 1/4 NYLOCK SS	2
9	18025718	BOLT CAP SS 1/4 X 3/4	2
10	57175	WIRE HARNESS W/ LOOM	2
11	57177	LOOM	2
12	70886	BUTT CONNECTOR	4

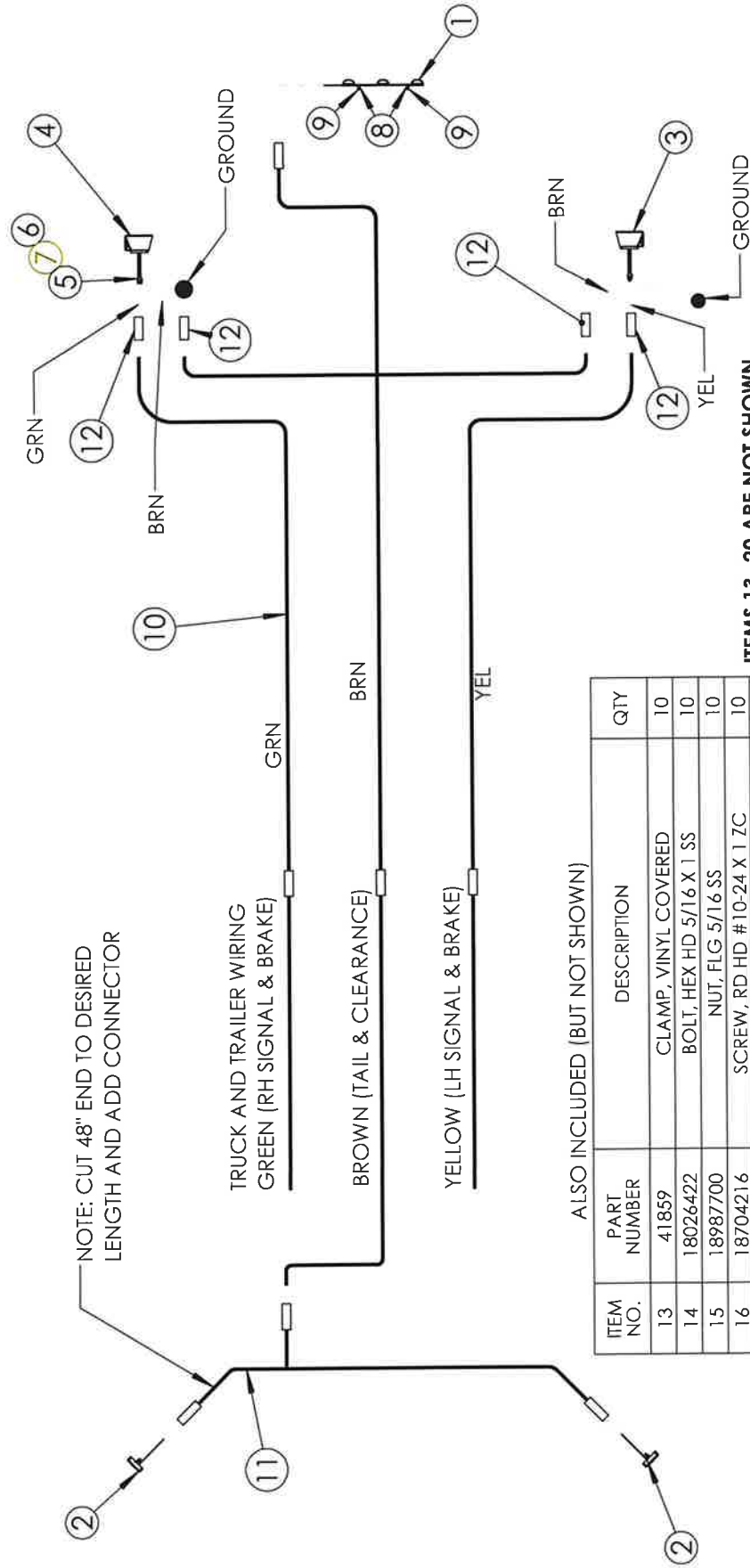

ITEMS 13 -20 ARE NOT SHOWN. BUT ARE USED TO SECURE WIRING AND PLUMBING COMPONENTS

ALSO INCLUDED (BUT NOT SHOWN)

ITEM NO.	PART NUMBER	DESCRIPTION	QTY
13	41859	CLAMP, VINYL COVERED	10
14	18026422	BOLT, HEX HD 5/16 X 1 SS	10
15	18987700	NUT, FLG 5/16 SS	10
16	18704216	SCREW, RD HD #10-24 X 1 ZC	10
17	18415812	NUT, HEX#10-24 SS	10
18	18881001	FLAT WASHER, 1/4 SS	10
19	18475700	NUT, 1/4 SS	4
20	57182	CLIP, LARGE FRAME	6

UNLOAD AUGER FLOOD LIGHT WIRING DIAGRAM

47000199
RV:A 02/28/19

P/N: 47000199 (includes: wiring harness QWH759, lights QFA199, and mounting brackets 47076486)

- WIRE HARNESS DIAGRAM IS FOR ILLUSTRATION ONLY
- ACTUAL WIRE HARNESS LENGTHS AND WIRE GAUGE ARE NOT TO SCALE
- ACTUAL WIRE HARNESS COMPONENTS ARE NOT TO SCALE

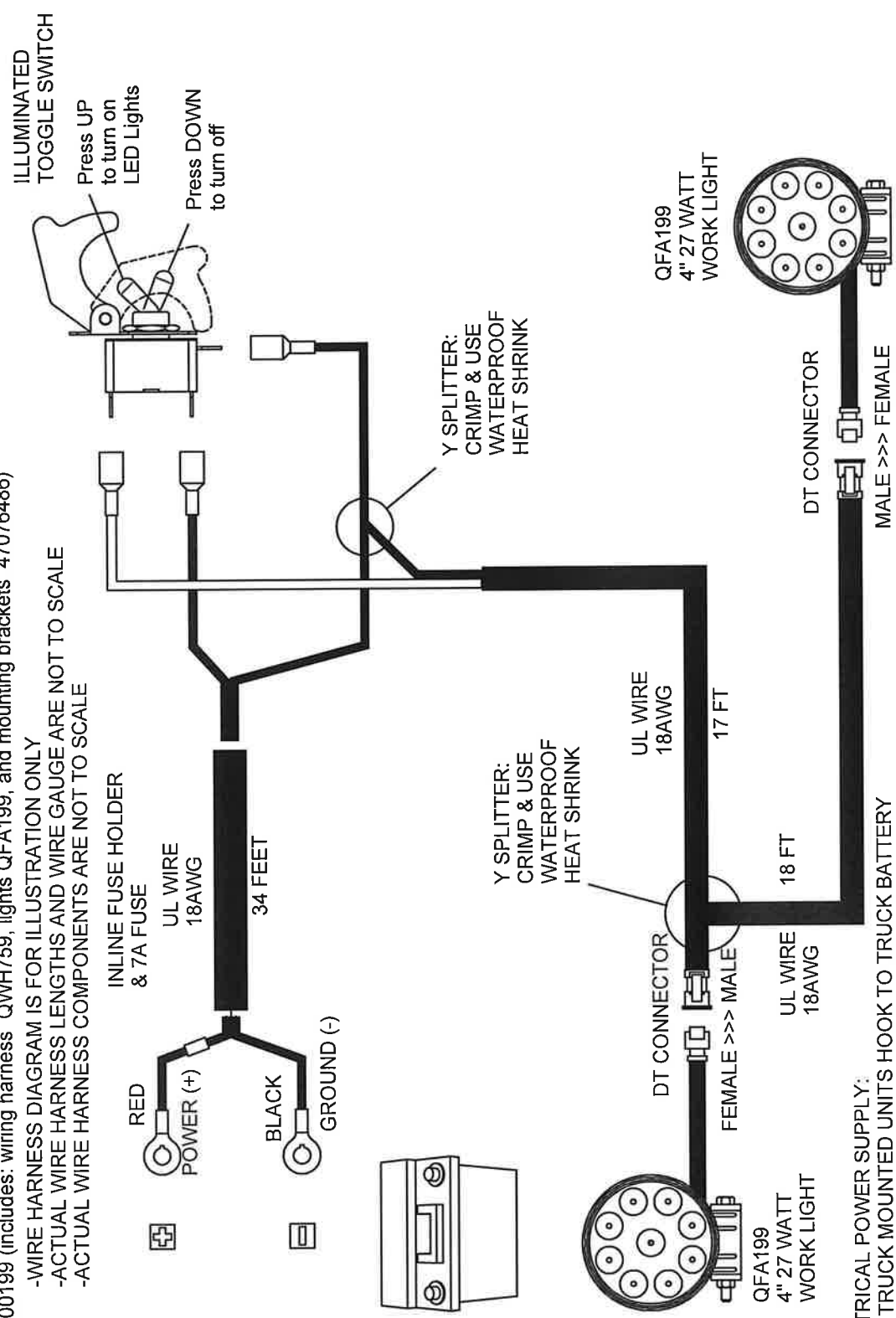

- ELECTRICAL POWER SUPPLY:
- FOR TRUCK MOUNTED UNITS HOOK TO TRUCK BATTERY
 - FOR TRAILER MOUNTED TENDER W/ KUBOTA ENGINE PACKAGE, HOOK TO KUBOTA'S BATTERY
 - (OPTIONAL) FOR FELLING TRAILERS HOOK DIRECTLY TO STUDED JUNCTION BOX P/N: AC2831, LOCATED IN FRONT OF THE REAR AXLE (JUNCTION BOX ONLY: CONNECT POWER TO STUD MARKED "AUX" (BLUE WIRE)/ CONNECT GROUND TO STUD MARKED "GRD" (WHITE WIRE))

**EATON MOTORS SUBSTITUTED FOR PARKER MOTORS
BEGINNING FALL OF 2023**

SERIAL # BEGINNING

MT600 – S/N: 1023

MT900 – S/N: 1120

MT700 – S/N: 1005

VPA1000 – S/N: 1012

(UPDATED HYDRAULIC LAYOUT PAGES MARKED WITH E)

PARKER AND EATON HYDRAULIC MOTOR CROSS REFERENCE INFORMATION

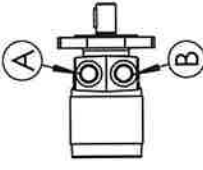
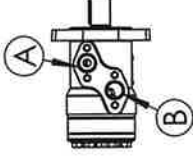
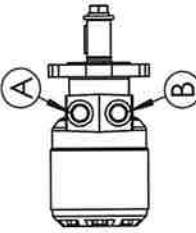
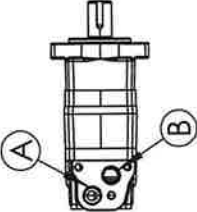
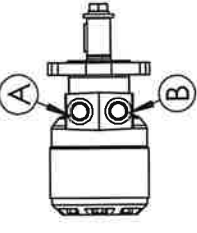
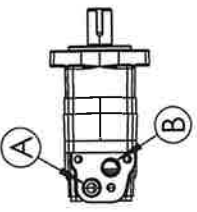
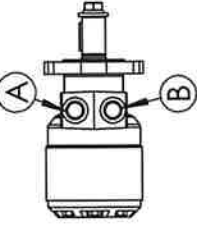
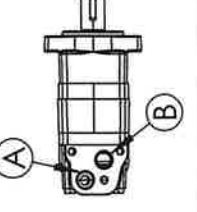
MOTOR FUNCTION	PARKER PART NUMBER	PARKER PORTS	PARKER PRESSURE PORT (FLOW IN)	EATON PART NUMBER	EATON PORTS	EATON PRESSURE PORT (FLOW IN)
ROTATE (GEARBOX)	1028801		A	71891		A
LOWER AUGER	1040020		A	71892		A
VERTICAL AUGER	1116558		A	71893		A
DISCHARGE AUGER	1040045		A	71894		B

CONVERSION INSTRUCTIONS:

WHEN CONVERTING BETWEEN PARKER AND EATON MOTORS PLUMB SUCH THAT THE FLOW ENTERS THE PRESSURE PORT NOTED IN THE TABLE ABOVE TO ENSURE CORRECT AUGER ROTATION.

FITTINGS AND HOSES ARE THE SAME - THE HOSES FOR THE DISCHARGE AUGER WILL NEED TO BE ADJUSTED TOWARD THE MOTOR APPROXIMATELY 6".

MT600 PLUMBING SCHEMATIC (TRUCK MOUNT)(PARKER)

MT600TRUCK
REV 11/18/22

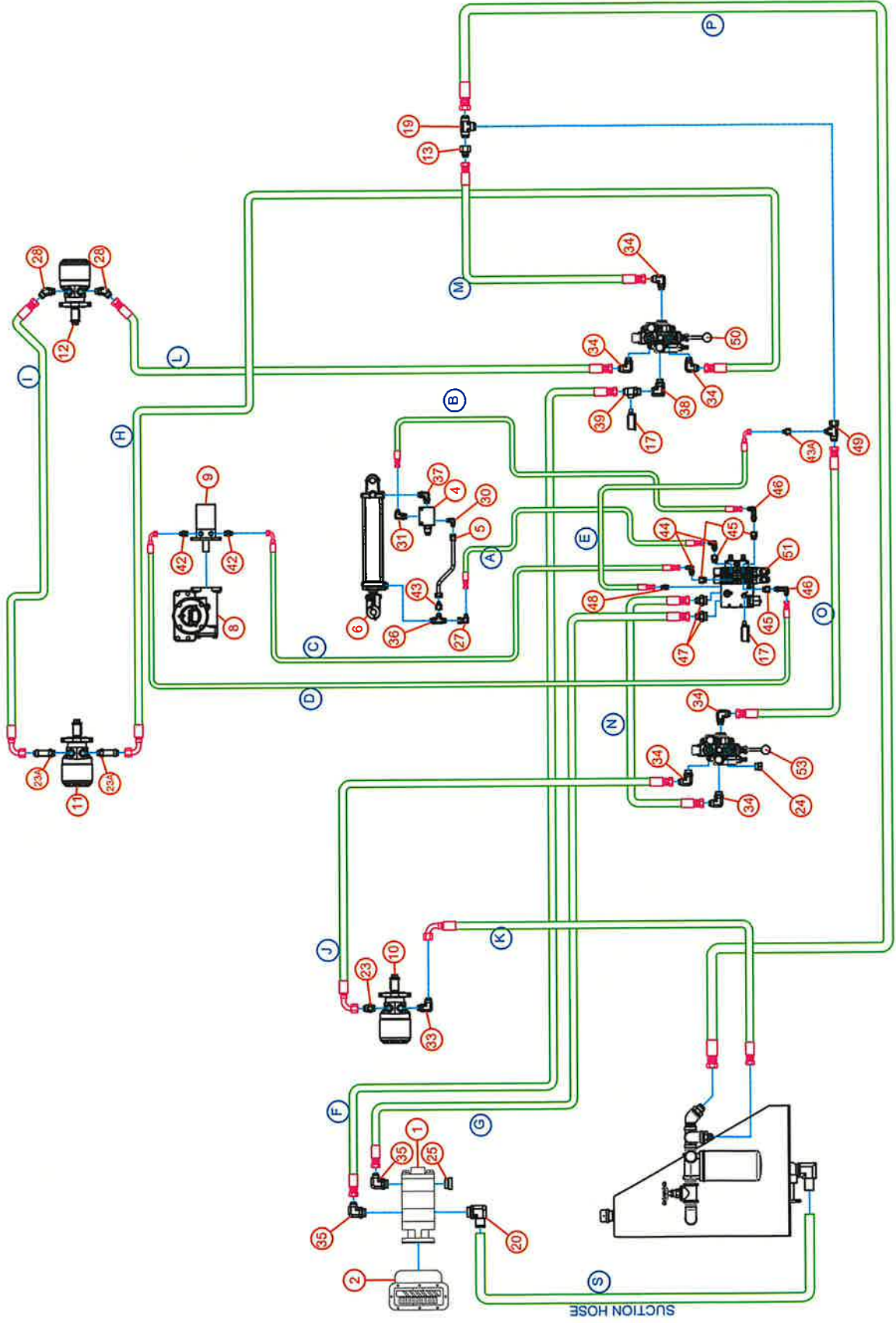

MT600 HYDRAULIC PLUMBING (TRUCK MOUNT)(PARKER)

ITEM	PART NO.	DESCRIPTION	QTY	ITEM	PART NO.	DESCRIPTION	QTY
1	1037666	HYDRAULIC PUMP	1	44	6801-06-06	ELBOW 90° #6 MJIC X #6 M O-RING	2
2	-	PTO ADAPTER (TO BE DETERMINED BY TRUCK)	1	45	6410-08-06	ADAPTER #8 M O-RING X #6 F O-RING S	4
3	-	OMITTED	1	46	6801-LL-06-06	ELBOW 90° EXTRA LONG #6 MJIC X #6 M O-RING2	2
4	1012830	COUNTER BALANCE LOCK (5:1 RATIO 2000 PSI)	1	47	6400-12-16	ADAPTER #12 MJIC X #16 M O-RING	2
5	100177A	FLARED CB TUBE	1	48	6400-06-06	ADAPTER #6 MJIC X #6 M O-RING	1
6	47005491	HYDRAULIC CYLINDER (3 X 14)	1	49	6602-12-12-12	TEE #12 MJIC X #12 FJICS X #12 MJIC	1
7	-	OMITTED	1	50	1132237	SINGLE SPOOL VALVE	1
8	1087194	GEAR BOX	1	51	1131625	DUAL SPOOL VALVE	1
9	1028801	MOTOR HYDRAULIC (GEAR BOX)	1	52	47076641	OIL TANK	1
10	1040020	MOTOR HYDRAULIC (LOWER AUGER)	1	53	1191269	SINGLE SPOOL VALVE (CLOSED)	1
11	1040045	MOTOR HYDRAULIC (DISCHARGE)	1				
12	1116558	MOTOR HYDRAULIC (VERTICAL)	1				
13	2406-16-12	ADAPTER #16 FJIC X #12 MJIC	1				
14	-	OMITTED	1				
15	-	OMITTED	1				
16	-	OMITTED	1				
17	25-901-SST-4000	4000 PSI PRESSURE GAUGE	2				
18	-	OMITTED	1				
19	2603-16-16-12	TEE #16 MJIC X #16 MJIC X #12 MJIC	1				
20	4601-24-20	HOSE BARB 90°	1				
21	-	OMITTED	1				
22	-	OMITTED	1				
23	6400-12-10W/S	ADAPTER 7/8 O-RING X #12 MJIC W/ SHOULDER	1				
23A	6400-L-12-10	ADAPTER, LONG 7/8 O-RING X #12 MJIC	2				
24	6408-12	#12 O-RING PLUG	1				
25	6408-H20	#20 O-RING PLUG, HOLLOW HEX	1				
26	-	OMITTED	1				
27	6500-06-08	ELBOW	1				
28	6802-12-10	ELBOW 45° #12 MJIC X #10 M O-RING	2				
29	-	OMITTED	1				
30	6801-06-04	ELBOW #6 MJIC X #4 M O-RING	1				
31	6801-06-08	ELBOW #6 MJIC X #8 M O-RING	1				
32	-	OMITTED	1				
33	6801-12-10	3/4 X 5/8 O-RING STRAIGHT THD ELBOW	1				
34	6801-12-12	ELBOW #12 MJIC X #12 M O-RING	6				
35	6801-12-16	ELBOW #12 MJIC X #16 M O-RING	2				
36	6804-08-08-08	FITTING #8 MJIC X #8 MORB X #8 MJIC	1				
37	6807-08-08	ELBOW #8 MORB X #8 MORB	1				
38	6815-12-12	FITTING	1				
39	GP6400-12-12-4	GAUGE PORT ADAPTER	1				
40	-	OMITTED	1				
41	-	OMITTED	1				
42	6400-06-10	FITTING #6 MJIC X #10 M O-RING	2				
43	2406-08-06	FITTING #8 FJIC X #6 MJIC	1				
43A	2406-12-06	FITTING #12 FJIC X #6 MJIC	1				

REPLACEMENT SEAL KIT
FOR RAISE/ROTATE VALVE
FOR AUGER ENGAGEMENT VALVES
71779
71788

HOSE	PART NO.	DESCRIPTION	QTY
A	606155	3/8 HOSE X 155" #6 JICFS EA END	1
B	606144	3/8 HOSE X 144" #6 JICFS EA END	1
C	606089	3/8 HOSE X 89" #6 JICFS X #6 JICFS 90°	1
D	606086	3/8 HOSE X 86" #6 JICFS X #6 JICFS 90°	1
E	606017	3/8 HOSE X 17" #6 JICFS X #6 JICFS 90°	1
F	612170	3/4 HOSE X 170" #12 JICFS EA END	1
G	612160	3/4 HOSE X 160" #12 JICFS EA END	1
H	612397	3/4 HOSE X 397" #12 JICFS X #12 JICFS 90°	1
I	612397	3/4 HOSE X 397" #12 JICFS X #12 JICFS 90°	1
J	612180	3/4 HOSE X 180" #12 JICFS X #12 JICFS 90°	1
K	612038	3/4 HOSE X 38" #12 JICFS X #12 JICFS 90°	1
L	622082	3/4 HOSE X 82" #12 JICFS EA END	1
M	612027	3/4 HOSE X 27" #12 JICFS EA END	1
N	612024	3/4 HOSE X 24" #12 JICFS EA END	1
O	612012	3/4 HOSE X 12" #12 JICFS X #12 JICFS 90°	1
P	616171	1 HOSE X 171" #16 JICFS EA END	1
S	-	SUCTION HOSE (ø1 1/2 X TBD)	1

FITTING KIT P/N: 1120446, INCLUDES ITEMS 5,13-19,23-24,27-34,36-39 & 42-49
HOSE KIT P/N: 1124063, INCLUDES HOSES A-E, H-I, AND L-O

TO ORDER HYDRAULIC PUMP W/ FITTINGS USE P/N: 48300500
(CONTAINS ITEMS 1, 20, 25, AND 35)

TRUCK HYD. HOSE AND PLUMBING PACKAGE P/N: 48300600
CONTAINS:
47976641 (OIL TANK W/ FITTINGS) QTY 1
1120446 (FITTING KIT) QTY 1
1124063 (HOSE KIT) QTY 1
612170 (HOSE) QTY 1
612160 (HOSE) QTY 1
612180 (HOSE) QTY 1
612038 (HOSE) QTY 1
616171 (HOSE) QTY 1

REPLACEMENT HANDLES
660150004 - SINGLE SPOOL HANDLE (AUGER ENGAGEMENT)
1074373 - DUAL SPOOL HANDLE (ROTATE/LIFT)

MT600 PLUMBING SCHEMATIC (TRUCK MOUNT) (EATON)

MT600TRUCK EATON
REV 09/12/23

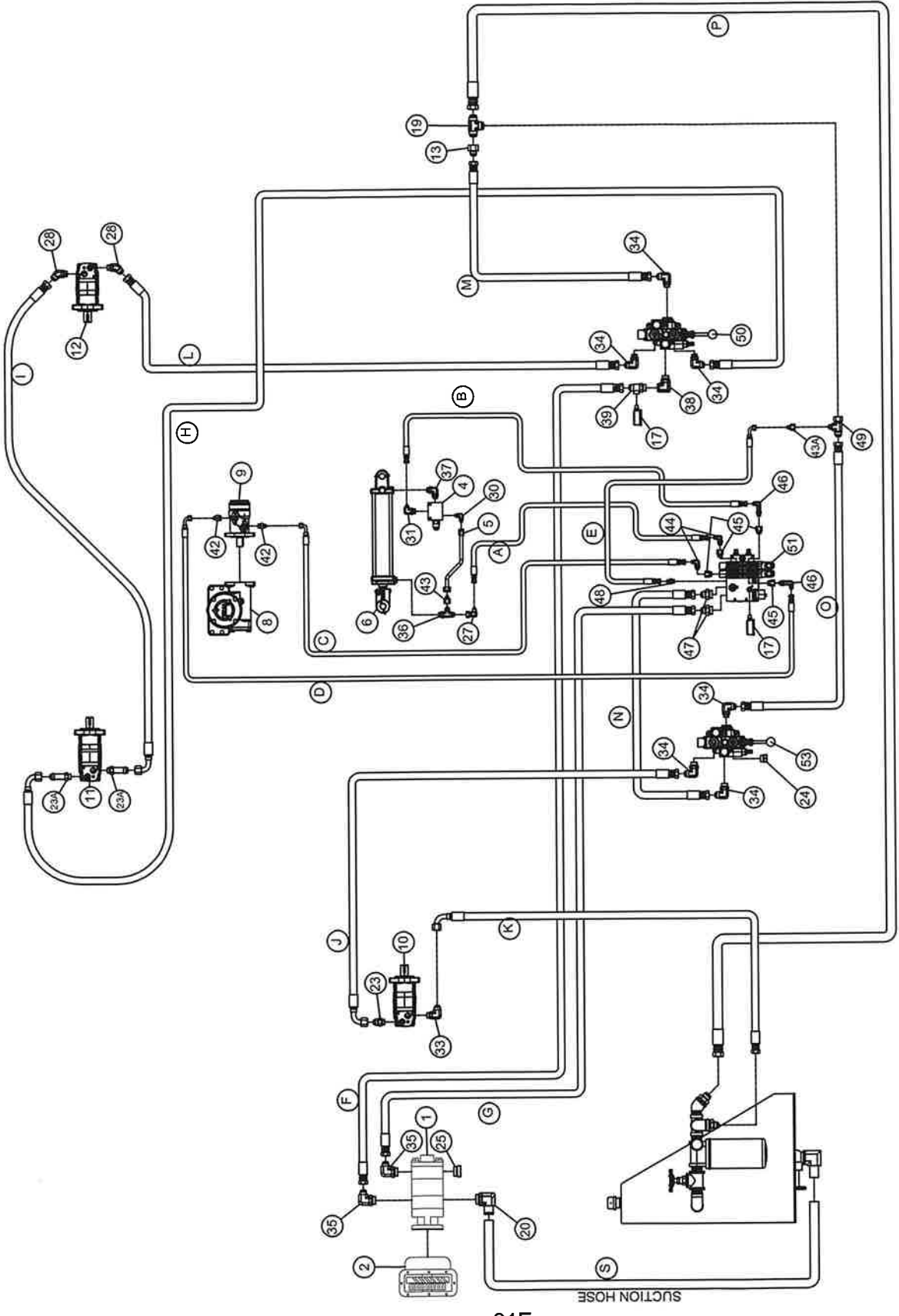

91E

EATON MOTORS SUBSTITUTED FOR PARKER STARTING FALL 2023 SERIAL NUMBER 1023

MT600 HYDRAULIC PLUMBING (TRUCK MOUNT)(EATON)

ITEM	PART NO.	DESCRIPTION	QTY	ITEM	PART NO.	DESCRIPTION	QTY
1	1037666	HYDRAULIC PUMP	1	44	6801-06-06	ELBOW 90° #6 MJIC X # 6 M O-RING	2
2	-	PTO ADAPTER (TO BE DETERMINED BY TRUCK)	1	45	6410-08-06	ADAPTER #8 M O-RING X #6 F O-RING S	4
3	-	OMITTED	-	46	6801-LL-06-06	ELBOW 90° EXTRA LONG #6 MJIC X # 6 M O-RING 2	2
4	1012830	COUNTER BALANCE LOCK (5:1 RATIO 2000 PSI)	1	47	6400-12-16	ADAPTER, #12 MJIC X #16 M O-RING	1
5	100177A	FLARED CB TUBE	1	48	6400-06-06	ADAPTER, #6 MJIC X #6 M O-RING	1
6	47005491	HYDRAULIC CYLINDER (3 X 14)	1	49	6602-12-12-12	TEE #12 MJIC X #12 FJICS X #12 MJIC	1
7	-	OMITTED	-	50	1132237	SINGLE SPOOL VALVE	1
8	1087194	GEAR BOX	1	51	1131625	DUAL SPOOL VALVE	1
9	71891	MOTOR HYDRAULIC (GEAR BOX)	1	52	47076641	OIL TANK	1
10	71892	MOTOR HYDRAULIC (LOWER AUGER)	1	53	1191269	SINGLE SPOOL VALVE (CLOSED)	1
11	71894	MOTOR HYDRAULIC (DISCHARGE)	1				
12	71893	MOTOR HYDRAULIC (VERTICAL)	1				
13	2406-16-12	ADAPTER #16 FJIC X #12 MJIC	1				
14	-	OMITTED	-				
15	-	OMITTED	-				
16	-	OMITTED	-				
17	25-901-SST-4000	4000 PSI PRESSURE GAUGE	2				
18	-	OMITTED	-				
19	2603-16-16-12	TEE #16 MJIC X #16 MJIC X #12 MJIC	1				
20	4601-24-20	HOSE BARB 90°	1				
21	-	OMITTED	-				
22	-	OMITTED	-				
23	6400-12-10W/S	ADAPTER 7/8 O-RING X #12 MJIC W/ SHOULDER	1				
23A	6400-L-12-10	ADAPTER, LONG 7/8 O-RING X #12 MJIC	2				
24	6408-12	#12 O-RING PLUG	1				
25	6408-H20	#20 O-RING PLUG, HOLLOW HEX	1				
26	-	OMITTED	-				
27	6500-06-08	ELBOW	1				
28	6802-12-10	ELBOW 45° #12 MJIC X #10 M O-RING	2				
29	-	OMITTED	-				
30	6801-06-04	ELBOW #6 MJIC X #4 M O-RING	1				
31	6801-06-08	ELBOW #6 MJIC X #8 M O-RING	1				
32	-	OMITTED	-				
33	6801-12-10	3/4 X 5/8 O-RING STRAIGHT THD ELBOW	1				
34	6801-12-12	ELBOW #12 MJIC X #12 M O-RING	6				
35	6801-12-16	ELBOW #12 MJIC X #16 M O-RING	2				
36	6804-08-08-08	FITTING #8 MJIC X #8 MORB X #8 MJIC	1				
37	6807-08-08	ELBOW #8 MORB X #8 MORB	1				
38	6815-12-12	FITTING	1				
39	GP6400-12-12-4	GAUGE PORT ADAPTER	1				
40	-	OMITTED	-				
41	-	OMITTED	-				
42	6400-06-10	FITTING #6 MJIC X #10 M O-RING	2				
43	2406-08-06	FITTING #8 FJIC X #6 MJIC	1				
43A	2406-12-06	FITTING #12 FJIC X #6 MJIC	1				

REPLACEMENT HANDLES
660150004 - SINGLE SPOOL HANDLE (AUGER ENGAGEMENT)
1074373 - DUAL SPOOL HANDLE (ROTATE/LIFT)

HOSE	PART NO.	DESCRIPTION	QTY
A	606155	3/8 HOSE X 155", #6 JICFS EA END	1
B	606144	3/8 HOSE X 144", #6 JICFS EA END	1
C	606089	3/8 HOSE X 89", #6 JICFS X #6 JICFS 90°	1
D	606086	3/8 HOSE X 86", #6 JICFS X #6 JICFS 90°	1
E	606017	3/8 HOSE X 17", #6 JICFS X #6 JICFS 90°	1
F	612170	3/4 HOSE X 170", #12 JICFS EA END	1
G	612160	3/4 HOSE X 160", #12 JICFS EA END	1
H	612397	3/4 HOSE X 397", #12 JICFS X #12 JICFS 90°	1
I	612397	3/4 HOSE X 397", #12 JICFS X #12 JICFS 90°	1
J	612180	3/4 HOSE X 180", #12 JICFS X #12 JICFS 90°	1
K	612038	3/4 HOSE X 38", #12 JICFS X #12 JICFS 90°	1
L	622082	3/4 HOSE X 82", #12 JICFS EA END	1
M	612027	3/4 HOSE X 27", #12 JICFS EA END	1
N	612024	3/4 HOSE X 24", #12 JICFS EA END	1
O	612012	3/4 HOSE X 12", #12 JICFS X #12 JICFS 90°	1
P	616171	1 HOSE X 171", #16 JICFS EA END	1
S	-	SUCTION HOSE (Ø 1 1/2 X TBD)	1

FITTING KIT P/N: 1120446, INCLUDES ITEMS 5,13-19,23-24,27-34,36-39 & 42-49
HOSE KIT P/N: 1124063, INCLUDES HOSES A-E, H-I, AND L-O

TO ORDER HYDRAULIC PUMP W/ FITTINGS USE P/N: 48300500
(CONTAINS ITEMS 1, 20, 25, AND 35)
TRUCK HYD. HOSE AND PLUMBING PACKAGE P/N: 48300600
CONTAINS:
47976641 (OIL TANK W/ FITTINGS) QTY 1
1120446 (FITTING KIT) QTY 1
1124063 (HOSE KIT) QTY 1
612170 (HOSE) QTY 1
612160 (HOSE) QTY 1
612180 (HOSE) QTY 1
612038 (HOSE) QTY 1
616171 (HOSE) QTY 1

MT900 PLUMBING SCHEMATIC (TRUCK MOUNT)(PARKER)

MT900TRUCK
REV 11/18/22

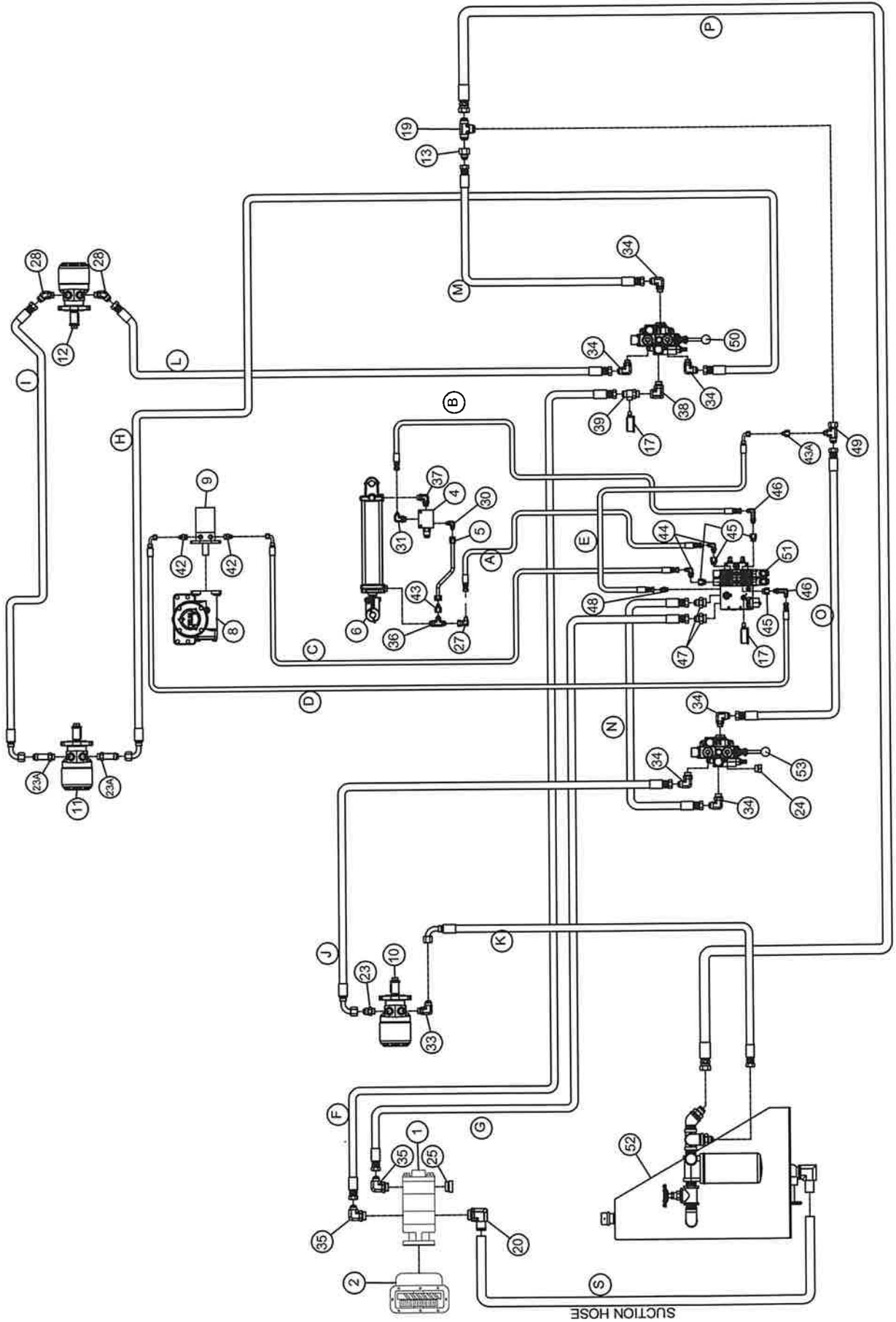

MT900 HYDRAULIC PLUMBING (TRUCK MOUNT)(PARKER)

ITEM	PART NO.	DESCRIPTION	QTY	ITEM	PART NO.	DESCRIPTION	QTY
1	1037666	HYDRAULIC PUMP	1	44	6801-06-06	ELBOW 90° #6 MJIC X # 6 M O-RING	2
2	-	PTO ADAPTER (TO BE DETERMINED BY TRUCK)	1	45	6410-08-06	ADAPTER #8 M O-RING X #6 F O-RING S	4
3	-	OMITTED	-	46	6801-LL-06-06	ELBOW 90° EXTRA LONG #6 MJIC X # 6 M O-RING 2	2
4	1012830	COUNTER BALANCE LOCK (5:1 RATIO 2000 PSI)	1	47	6400-12-16	ADAPTER, #12 MJIC X #16 M O-RING	1
5	100177A	FLARED CB TUBE	1	48	6400-06-06	ADAPTER, #6 MJIC X #6 M O-RING	1
6	47005491	HYDRAULIC CYLINDER (3 X 14)	1	49	6602-12-12-12	TEE #12 MJIC X #12 FJICS X #12 MJIC	1
7	-	OMITTED	-	50	1132237	SINGLE SPOOL VALVE	1
8	1087194	GEAR BOX	1	51	1131625	DUAL SPOOL VALVE	1
9	1028801	MOTOR HYDRAULIC (GEAR BOX)	1	52	47076641	OIL TANK	1
10	1040020	MOTOR HYDRAULIC (LOWER AUGER)	1	53	1191269	SINGLE SPOOL VALVE (CLOSED)	1
11	1040045	MOTOR HYDRAULIC (DISCHARGE)	1				
12	1116558	MOTOR HYDRAULIC (VERTICAL)	1				
13	2406-16-12	ADAPTER #16 FJIC X #12 MJIC	1				
14	-	OMITTED	-				
15	-	OMITTED	-				
16	-	OMITTED	-				
17	25-901-SST-4000	4000 PSI PRESSURE GAUGE	2				
18	-	OMITTED	-				
19	2603-16-16-12	TEE #16 MJIC X #16 MJIC X #12 MJIC	1				
20	4601-24-20	HOSE BARB 90°	1				
21	-	OMITTED	-				
22	-	OMITTED	-				
23	6400-12-10W/S	ADAPTER 7/8 O-RING X #12 MJIC W/ SHOULDER	1				
23A	6400-L-12-10	ADAPTER, LONG 7/8 O-RING X #12 MJIC	2				
24	6408-12	#12 O-RING PLUG	1				
25	6408-H20	#20 O-RING PLUG, HOLLOW HEX	1				
26	-	OMITTED	-				
27	6500-06-08	ELBOW	1				
28	6802-12-10	ELBOW 45° #12 MJIC X #10 M O-RING	2				
29	-	OMITTED	-				
30	6801-06-04	ELBOW #6 MJIC X #4 M O-RING	1				
31	6801-06-08	ELBOW #6 MJIC X #8 M O-RING	1				
32	-	OMITTED	-				
33	6801-12-10	3/4 X 5/8 O-RING STRAIGHT THD ELBOW	1				
34	6801-12-12	ELBOW #12 MJIC X #12 M O-RING	6				
35	6801-12-16	ELBOW #12 MJIC X #16 M O-RING	2				
36	6804-08-08-08	FITTING #8 MJIC X #8 MORB X #8 MJIC	1				
37	6807-08-08	ELBOW #8 MORB X #8 MORB	1				
38	6815-12-12	FITTING	1				
39	GP6400-12-12-4	GAUGE PORT ADAPTER	1				
40	-	OMITTED	-				
41	-	OMITTED	-				
42	6400-06-10	FITTING #6 MJIC X #10 M O-RING	2				
43	2406-08-06	FITTING #8 FJIC X #6 MJIC	1				
43A	2406-12-06	FITTING #12 FJIC X #6 MJIC	1				

REPLACEMENT SEAL KIT
71779 FOR RAISE/ROTATE VALVE
71788 FOR AUGER ENGAGEMENT VALVES

HOSE	PART NO.	DESCRIPTION	QTY
A	606155	3/8 HOSE X 155", #6 JICFS EA END	1
B	606144	3/8 HOSE X 144", #6 JICFS EA END	1
C	606089	3/8 HOSE X 89", #6 JICFS X #6 JICFS 90°	1
D	606086	3/8 HOSE X 86", #6 JICFS X #6 JICFS 90°	1
E	606017	3/8 HOSE X 17", #6 JICFS X #6 JICFS 90°	1
F	612270	3/4 HOSE X 270", #12 JICFS EA END	1
G	612260	3/4 HOSE X 260", #12 JICFS EA END	1
H	612397	3/4 HOSE X 397", #12 JICFS X #12 JICFS 90°	1
I	612397	3/4 HOSE X 397", #12 JICFS X #12 JICFS 90°	1
J	612280	3/4 HOSE X 280", #12 JICFS X #12 JICFS 90°	1
K	612038	3/4 HOSE X 38", #12 JICFS X #12 JICFS 90°	1
L	622082	3/4 HOSE X 82", #12 JICFS EA END	1
M	612027	3/4 HOSE X 27", #12 JICFS EA END	1
N	612024	3/4 HOSE X 24", #12 JICFS EA END	1
O	612012	3/4 HOSE X 12", #12 JICFS X #12 JICFS 90°	1
P	616267	1 HOSE X 267", #16 JICFS EA END	1
S	-	SUCTION HOSE (ø1 1/2 X TBD)	1

FITTING KIT P/N: 1120446, INCLUDES ITEMS 5,13-19,23-24,27-34,36-39, & 42-49
HOSE KIT P/N: 1124063, INCLUDES HOSES A-E, H-I, AND L-O

TO ORDER HYDRAULIC PUMP W/ FITTINGS USE P/N: 48300500
(CONTAINS ITEMS 1, 20, 25, AND 35)

TRUCK HYD. HOSE AND PLUMBING PACKAGE P/N: 48300900
CONTAINS:
47976641 (OIL TANK W/ FITTINGS) QTY 1
1120446 (FITTING KIT) QTY 1
1124063 (HOSE KIT) QTY 1
612270 (HOSE) QTY 1
612260 (HOSE) QTY 1
612280 (HOSE) QTY 1
612038 (HOSE) QTY 1
616267 (HOSE) QTY 1

REPLACEMENT HANDLES
660150004 - SINGLE SPOOL HANDLE (AUGER ENGAGEMENT)
1074373 - DUAL SPOOL HANDLE (ROTATE/LIFT)

MT900 PLUMBING SCHEMATIC (TRUCK MOUNT) (EATON)

MT900TRUCK EATON
REV 11/18/22

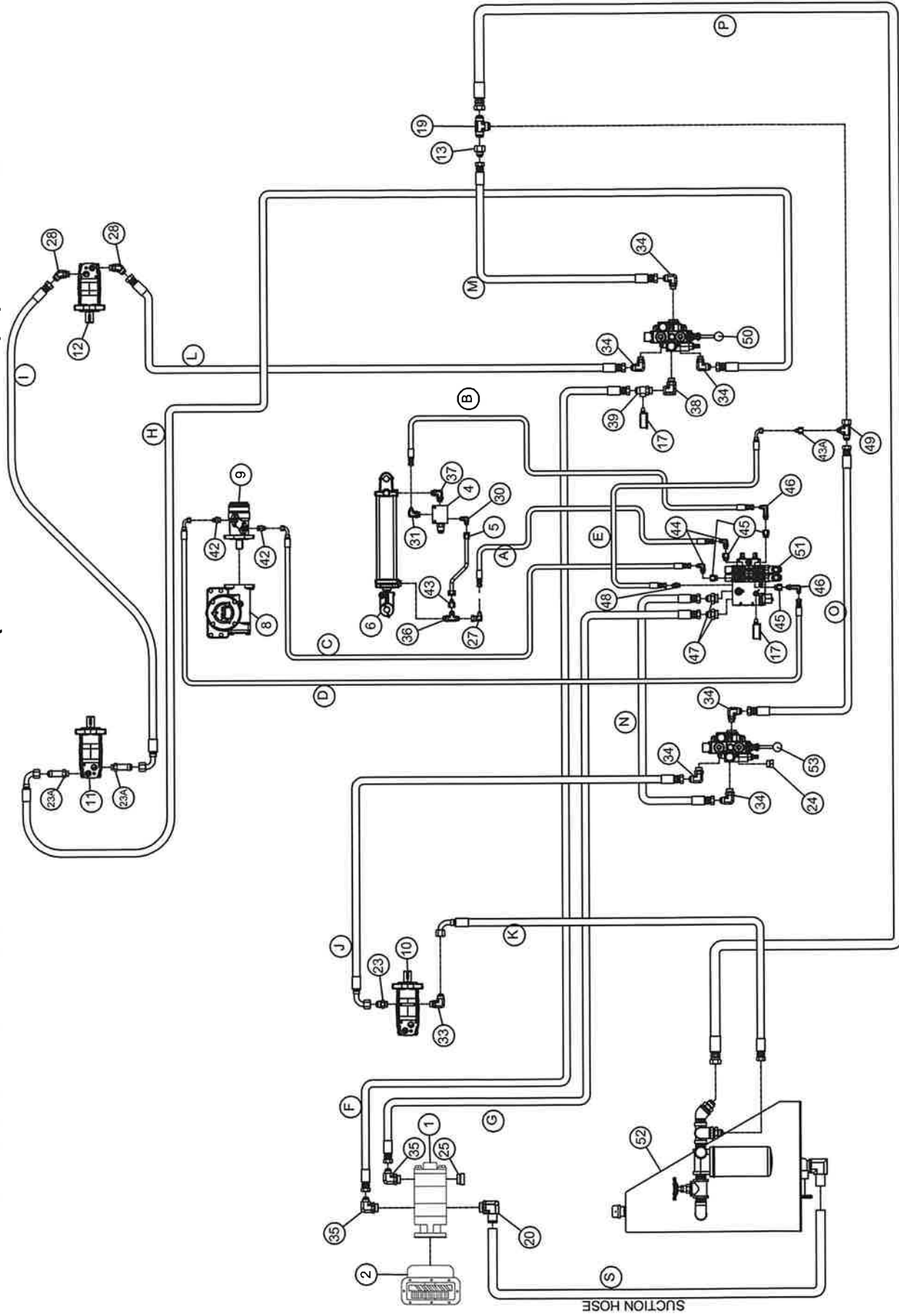

93E

EATON MOTORS SUBSTITUTED FOR PARKER STARTING FALL 2023 SERIAL NUMBER 1120

MT900 HYDRAULIC PLUMBING (TRUCK MOUNT) (EATON)

ITEM	PART NO.	DESCRIPTION	QTY	ITEM	PART NO.	DESCRIPTION	QTY
1	1037666	HYDRAULIC PUMP	1	44	6801-06-06	ELBOW 90° #6 MJIC X # 6 M O-RING	2
2	-	PTO ADAPTER (TO BE DETERMINED BY TRUCK)	1	45	6410-08-06	ADAPTER #8 M O-RING X #6 F O-RING S	4
3	-	OMITTED	-	46	6801-LL-06-06	ELBOW 90°, EXTRA LONG #6 MJIC X # 6 M O-RING 2	2
4	1012830	COUNTER BALANCE LOCK (5:1 RATIO 2000 PSI)	1	47	6400-12-16	ADAPTER, #12 MJIC X #16 M O-RING	1
5	100177A	FLARED CB TUBE	1	48	6400-06-06	ADAPTER, #6 MJIC X #6 M O-RING	1
6	47005491	HYDRAULIC CYLINDER (3 X 14)	1	49	6602-12-12-12	TEE #12 MJIC X #12 FJICS X #12 MJIC	1
7	-	OMITTED	-	50	1132237	SINGLE SPOOL VALVE	1
8	1087194	GEAR BOX	1	51	1131625	DUAL SPOOL VALVE	1
9	71891	MOTOR HYDRAULIC (GEAR BOX)	1	52	47076641	OIL TANK	1
10	71892	MOTOR HYDRAULIC (LOWER AUGER)	1	53	1191269	SINGLE SPOOL VALVE (CLOSED)	1
11	71894	MOTOR HYDRAULIC (DISCHARGE)	1				
12	71893	MOTOR HYDRAULIC (VERTICAL)	1				
13	2406-16-12	ADAPTER #16 FJIC X #12 MJIC	1				
14	-	OMITTED	-				
15	-	OMITTED	-				
16	-	OMITTED	-				
17	25-901-SST-4000	4000 PSI PRESSURE GAUGE	2				
18	-	OMITTED	-				
19	2603-16-16-12	TEE #16 MJIC X #16 MJIC X #12 MJIC	1				
20	4601-24-20	HOSE BARB 90°	1				
21	-	OMITTED	-				
22	-	OMITTED	-				
23	6400-12-10W/S	ADAPTER 7/8 O-RING X #12 MJIC W/ SHOULDER	2				
23A	6400-L-12-10	ADAPTER, LONG 7/8 O-RING X #12 MJIC	1				
24	6408-12	#12 O-RING PLUG	1				
25	6408-H20	#20 O-RING PLUG, HOLLOW HEX	1				
26	-	OMITTED	-				
27	6500-06-08	ELBOW 45° #12 MJIC X #10 M O-RING	1				
28	6802-12-10	ELBOW 45° #12 MJIC X #10 M O-RING	2				
29	-	OMITTED	-				
30	6801-06-04	ELBOW #6 MJIC X #4 M O-RING	1				
31	6801-06-08	ELBOW #6 MJIC X #8 M O-RING	1				
32	-	OMITTED	-				
33	6801-12-10	3/4 X 5/8 O-RING STRAIGHT THD ELBOW	1				
34	6801-12-12	ELBOW #12 MJIC X #12 M O-RING	6				
35	6801-12-16	ELBOW #12 MJIC X #16 M O-RING	2				
36	6804-08-08-08	FITTING #8 MJIC X #8 MORB X #8 MJIC	1				
37	6807-08-08	ELBOW #8 MORB X #8 MORB	1				
38	6815-12-12	FITTING	1				
39	GP6400-12-12-4	GAUGE PORT ADAPTER	1				
40	-	OMITTED	-				
41	-	OMITTED	-				
42	6400-06-10	FITTING #6 MJIC X #10 M O-RING	2				
43	2406-08-06	FITTING #8 FJIC X #6 MJIC	1				
43A	2406-12-06	FITTING #12 FJIC X #6 MJIC	1				

REPLACEMENT SEAL KIT
FOR RAISE/ROTATE VALVE
FOR AUGER ENGAGEMENT VALVES

71779
71788

HOSE PART NO. DESCRIPTION QTY
A 606155 3/8 HOSE X 155", #6 JICFS EA END 1
B 606144 3/8 HOSE X 144", #6 JICFS EA END 1
C 606089 3/8 HOSE X 89", #6 JICFS X #6 JICFS 90° 1
D 606086 3/8 HOSE X 86", #6 JICFS X #6 JICFS 90° 1
E 606017 3/8 HOSE X 17", #6 JICFS X #6 JICFS 90° 1
F 612270 3/4 HOSE X 270", #12 JICFS EA END 1
G 612260 3/4 HOSE X 260", #12 JICFS EA END 1
H 612397 3/4 HOSE X 397", #12 JICFS X #12 JICFS 90° 1
I 612397 3/4 HOSE X 397", #12 JICFS X #12 JICFS 90° 1
J 612280 3/4 HOSE X 280", #12 JICFS X #12 JICFS 90° 1
K 612038 3/4 HOSE X 38", #12 JICFS X #12 JICFS 90° 1
L 622082 3/4 HOSE X 82", #12 JICFS EA END 1
M 612027 3/4 HOSE X 27", #12 JICFS EA END 1
N 612024 3/4 HOSE X 24", #12 JICFS EA END 1
O 612012 3/4 HOSE X 12", #12 JICFS X #12 JICFS 90° 1
P 616267 1 HOSE X 267", #16 JICFS EA END 1
S - SUCTION HOSE (ø1 1/2 X TBD) 1

FITTING KIT P/N: 1120446, INCLUDES ITEMS 5,13-19,23-24,27-34,36-39, & 42-49
HOSE KIT P/N: 1124063, INCLUDES HOSES A-E, H-I, AND L-O

TO ORDER HYDRAULIC PUMP W/ FITTINGS USE P/N: 48300500
(CONTAINS ITEMS 1, 20, 25, AND 35)
TRUCK HYD. HOSE AND PLUMBING PACKAGE P/N: 48300900
CONTAINS:
47976641 (OIL TANK W/ FITTINGS) QTY 1
1120446 (FITTING KIT) QTY 1
1124063 (HOSE KIT) QTY 1
612270 (HOSE) QTY 1
612260 (HOSE) QTY 1
612280 (HOSE) QTY 1
612038 (HOSE) QTY 1
616267 (HOSE) QTY 1

REPLACEMENT HANDLES
660150004 - SINGLE SPOOL HANDLE (AUGER ENGAGEMENT)
1074373 - DUAL SPOOL HANDLE (ROTATE/LIFT)

MT900 HYDRAULIC PLUMBING (TRAILER MOUNT)(PARKER)

ITEM	PART NO.	DESCRIPTION	QTY	ITEM	PART NO.	DESCRIPTION	QTY
1	MT900TAPUMP	HYDRAULIC PUMP (TWIN GEAR 27GPM @ 2600RPM)	1	44	6801-06-06	ELBOW 90° #6 MJIC X #6 M O-RING	2
2	-	OMITTED	-	45	6410-08-06	ADAPTER #8 M O-RING X #6 F O-RING S	4
3	-	OMITTED	-	46	6801-LL-06-06	ELBOW 90° EXTRA LONG #6 MJIC X #6 M O-RING 2	2
4	1012830	COUNTER BALANCE LOCK (5:1 RATIO 2000 PSI)	1	47	6400-12-16	ADAPTER, #12 MJIC X #16 M O-RING	1
5	100177A	FLARED CB TUBE	1	48	6400-06-06	ADAPTER, #6 MJIC X #6 M O-RING	1
6	47005491	HYDRAULIC CYLINDER (3 X 14)	1	49	6602-12-12-12	TEE #12 MJIC X #12 FJICS X #12 MJIC	1
7	-	OMITTED	-	50	1132237	SINGLE SPOOL VALVE	1
8	1087194	GEAR BOX	1	51	1131625	DUAL SPOOL VALVE	1
9	1028801	MOTOR HYDRAULIC (GEAR BOX)	1	52	1191269	SINGLE SPOOL VALVE (CLOSED)	1
10	1040020	MOTOR HYDRAULIC (LOWER AUGER)	1	REPLACEMENT SEAL KIT			
11	1040045	MOTOR HYDRAULIC (DISCHARGE)	1				
12	1116558	MOTOR HYDRAULIC (VERTICAL)	1	71779	FOR RAISE/ROTATE VALVE	1	
13	2406-16-12	ADAPTER #16 FJIC X #12 MJIC	1	71788	FOR AUGER ENGAGEMENT VALVES	1	
14	-	OMITTED	-	HOSE			
15	-	OMITTED	-				
16	-	OMITTED	-	A	606155	3/8 HOSE X 155", #6 JICFS EA END	1
17	25-901-SST-4000	4000 PSI PRESSURE GAUGE	2	B	606144	3/8 HOSE X 144", #6 JICFS EA END	1
18	-	OMITTED	-	C	606089	3/8 HOSE X 89", #6 JICFS X #6 JICFS 90°	1
19	2603-16-16-12	TEE #16 MJIC X #16 MJIC X #12 MJIC	1	D	606086	3/8 HOSE X 86", #6 JICFS X #6 JICFS 90°	1
20	4601-24-20	HOSE BARB 90°	1	E	606017	3/8 HOSE X 17", #6 JICFS X #6 JICFS 90°	1
21	-	OMITTED	-	F	612424	3/4 HOSE X 424", #12 JICFS EA END	1
22	-	OMITTED	-	G	612404	3/4 HOSE X 404", #12 JICFS EA END	1
23	6400-12-10W/S	ADAPTER 7/8 O-RING X #12 MJIC W/ SHOULDER	2	H	612397	3/4 HOSE X 397", #12 JICFS X #12 JICFS 90°	1
23A	6400-L-12-10	ADAPTER, LONG 7/8 O-RING X #12 MJIC	1	I	612397	3/4 HOSE X 397", #12 JICFS X #12 JICFS 90°	1
24	6408-12	#12 O-RING PLUG	1	J	612287	3/4 HOSE X 287", #12 JICFS X #12 JICFS 90°	1
25	6408-20	#20 O-RING PLUG	1	K	612142	3/4 HOSE X 142", #12 JICFS X #12 JICFS 90°	1
26	-	OMITTED	-	L	622082	3/4 HOSE X 82", #12 JICFS EA END	1
27	6500-06-08	ELBOW	1	M	612027	3/4 HOSE X 27", #12 JICFS EA END	1
28	6802-12-10	ELBOW 45° #12 MJIC X #10 M O-RING	2	N	612024	3/4 HOSE X 24", #12 JICFS EA END	1
29	-	OMITTED	-	O	612012	3/4 HOSE X 12", #12 JICFS X #12 JICFS 90°	1
30	6801-06-04	ELBOW #6 MJIC X #4 M O-RING	1	P	616402	1 HOSE X 402", #16 JICFS EA END	1
31	6801-06-08	ELBOW #6 MJIC X #8 M O-RING	1	S	12003501	SUCTION HOSE (ø1 1/2 X 22 3/8 LG)	1
32	-	OMITTED	-	FITTING KIT P/N: 1120446, INCLUDES ITEMS 5,13-19,23-24,27-34,36-39, & 42-49 HOSE KIT P/N: 1124063, INCLUDES HOSES A-E, H-I, AND L-O			
33	6801-12-10	3/4 X 5/8 O-RING STRAIGHT THD ELBOW	1				
34	6801-12-12	ELBOW #12 MJIC X #12 M O-RING	6	CONTAINS: 1120446 (FITTING KIT) - 1 1124063 (HOSE KIT) - 1			
35	6801-12-16	ELBOW #12 MJIC X #16 M O-RING	2				
36	6804-08-08-08	FITTING #8 MJIC X #8 MORB X #8 MJIC	1	612424 (HOSE) - 1			
37	6807-08-08	ELBOW #8 MORB X #8 MORB	1	612404 (HOSE) - 1			
38	6815-12-12	FITTING	1	612287 (HOSE) - 1			
39	GP6400-12-12-4	GAUGE PORT ADAPTER	1	612142 (HOSE) - 1			
40	-	OMITTED	-	616402 (HOSE) - 1			
41	-	OMITTED	-	TO ORDER HYDRAULIC PUMP WITH FITTINGS, USE P/N: 48300501 (CONTAINS ITEMS 1, 20, 25 & 35)			
42	6400-06-10	FITTING #6 MJIC X #10 M O-RING	2				
43	2406-08-06	FITTING #8 FJIC X #6 MJIC	1				
43A	2406-12-06	FITTING #12 FJIC X #6 MJIC	1				

REPLACEMENT HANDLES
660150004 - SINGLE SPOOL HANDLE (AUGER ENGAGEMENT)
1074373 - DUAL SPOOL HANDLE (ROTATE/LIFT)

MT900 PLUMBING SCHEMATIC (TRAILER MOUNT) (EATON)

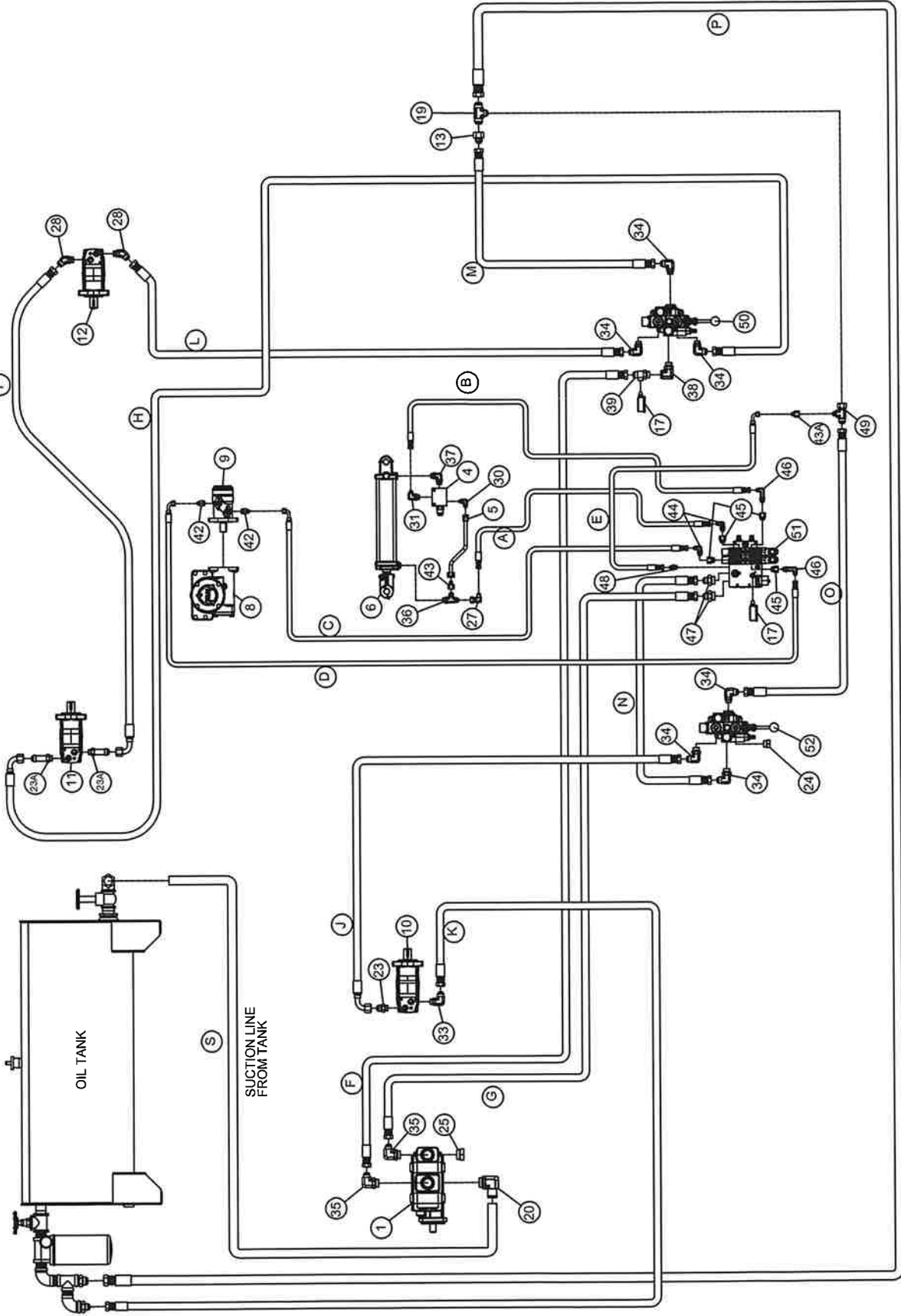

MT900 HYDRAULIC PLUMBING (TRAILER MOUNT)(EATON)

ITEM	PART NO.	DESCRIPTION	QTY	ITEM	PART NO.	DESCRIPTION	QTY
1	MT900TAPUMP	HYDRAULIC PUMP (TWIN GEAR 27GPM @ 2600RPM)	1	44	6801-06-06	ELBOW 90° #6 MJIC X # 6 M O-RING	2
2	-	OMITTED	-	45	6410-08-06	ADAPTER #8 M O-RING X #6 F O-RING S	4
3	-	OMITTED	-	46	6801-LL-06-06	ELBOW 90° EXTRA LONG #6 MJIC X # 6 M O-RING 2	2
4	1012830	COUNTER BALANCE LOCK (5:1 RATIO 2000 PSI)	1	47	6400-12-16	ADAPTER, #12 MJIC X #16 M O-RING	2
5	100177A	FLARED CB TUBE	1	48	6400-06-06	ADAPTER, #6 MJIC X #6 M O-RING	1
6	47005491	HYDRAULIC CYLINDER (3 X 14)	1	49	6602-12-12-12	TEE #12 MJIC X #12 FJICS X #12 MJIC	1
7	-	OMITTED	-	50	1132237	SINGLE SPOOL VALVE	1
8	1087194	GEAR BOX	1	51	1131625	DUAL SPOOL VALVE	1
9	71891	MOTOR HYDRAULIC (GEAR BOX)	1	52	1191269	SINGLE SPOOL VALVE (CLOSED)	1
10	71892	MOTOR HYDRAULIC (LOWER AUGER)	1	REPLACEMENT SEAL KIT			
11	71894	MOTOR HYDRAULIC (DISCHARGE)	1				
12	71893	MOTOR HYDRAULIC (VERTICAL)	1				
13	2406-16-12	ADAPTER #16 FJIC X #12 MJIC	1	71779	FOR RAISE/ROTATE VALVE		1
14	-	OMITTED	-	71788	FOR AUGER ENGAGEMENT VALVES		1
15	-	OMITTED	-	HOSE			
16	-	OMITTED	-				
17	25-901-SST-4000	4000 PSI PRESSURE GAUGE	2				
18	-	OMITTED	-	A	606155	3/8 HOSE X 155", #6 JICFS EA END	1
19	2603-16-16-12	TEE #16 MJIC X #16 MJIC X #12 MJIC	1	B	606144	3/8 HOSE X 144", #6 JICFS EA END	1
20	4601-24-20	HOSE BARB 90°	1	C	606089	3/8 HOSE X 89", #6 JICFS X #6 JICFS 90°	1
21	-	OMITTED	-	D	606086	3/8 HOSE X 86", #6 JICFS X #6 JICFS 90°	1
22	-	OMITTED	-	E	606017	3/8 HOSE X 17", #6 JICFS X #6 JICFS 90°	1
23	6400-12-10W/S	ADAPTER 7/8 O-RING X #12 MJIC W/ SHOULDER	1	F	612424	3/4 HOSE X 424", #12 JICFS EA END	1
23A	6400-L-12-10	ADAPTER, LONG 7/8 O-RING X #12 MJIC	2	G	612404	3/4 HOSE X 404", #12 JICFS EA END	1
24	6408-12	#12 O-RING PLUG	1	H	612397	3/4 HOSE X 397", #12 JICFS X #12 JICFS 90°	1
25	6408-20	#20 O-RING PLUG	1	I	612397	3/4 HOSE X 397", #12 JICFS X #12 JICFS 90°	1
26	-	OMITTED	-	J	612287	3/4 HOSE X 287", #12 JICFS X #12 JICFS 90°	1
27	6500-06-08	ELBOW	1	K	612142	3/4 HOSE X 142", #12 JICFS EA END	1
28	6802-12-10	ELBOW 45° #12 MJIC X #10 M O-RING	2	L	622082	3/4 HOSE X 82", #12 JICFS EA END	1
29	-	OMITTED	-	M	612027	3/4 HOSE X 27", #12 JICFS EA END	1
30	6801-06-04	ELBOW #6 MJIC X #4 M O-RING	1	N	612024	3/4 HOSE X 24", #12 JICFS EA END	1
31	6801-06-08	ELBOW #6 MJIC X #8 M O-RING	1	O	612012	3/4 HOSE X 12", #12 JICFS X #12 JICFS 90°	1
32	-	OMITTED	-	P	616402	1 HOSE X 402", #16 JICFS EA END	1
33	6801-12-10	3/4 X 5/8 O-RING STRAIGHT THD ELBOW	1	S	12003501	SUCTION HOSE (Ø1 1/2 X 22 3/8 LG)	1
34	6801-12-12	ELBOW #12 MJIC X #12 M O-RING	6	FITTING KIT P/N: 1120446, INCLUDES ITEMS 5,13-19,23-24,27-34,36-39, & 42-49 HOSE KIT P/N: 1124063, INCLUDES HOSES A-E, H-I, AND L-O HYDRAULIC HOSE PACKAGE TO FRONT OF TRAILER P/N: 48300901 CONTAINS: 1120446 (FITTING KIT) - 1 1124063 (HOSE KIT) - 1 612424 (HOSE) - 1 612404 (HOSE) - 1 612287 (HOSE) - 1 612142 (HOSE) - 1 616402 (HOSE) - 1			
35	6801-12-16	ELBOW #12 MJIC X #16 M O-RING	2				
36	6804-08-08-08	FITTING #8 MJIC X #8 MORB X #8 MJIC	1				
37	6807-08-08	ELBOW #8 MORB X #8 MORB	1				
38	6815-12-12	FITTING	1				
39	GP6400-12-12-4	GAUGE PORT ADAPTER	1				
40	-	OMITTED	-				
41	-	OMITTED	-				
42	6400-06-10	FITTING #6 MJIC X #10 M O-RING	2				
43	2406-08-06	FITTING #8 FJIC X #6 MJIC	1				
43A	2406-12-06	FITTING #12 FJIC X #6 MJIC	1				

REPLACEMENT HANDLES
660150004 - SINGLE SPOOL HANDLE (AUGER ENGAGEMENT)
1074373 - DUAL SPOOL HANDLE (ROTATE/LIFT)

MT900 PLUMBING SCHEMATIC (TRAILER MOUNT - WET KIT)(PARKER)

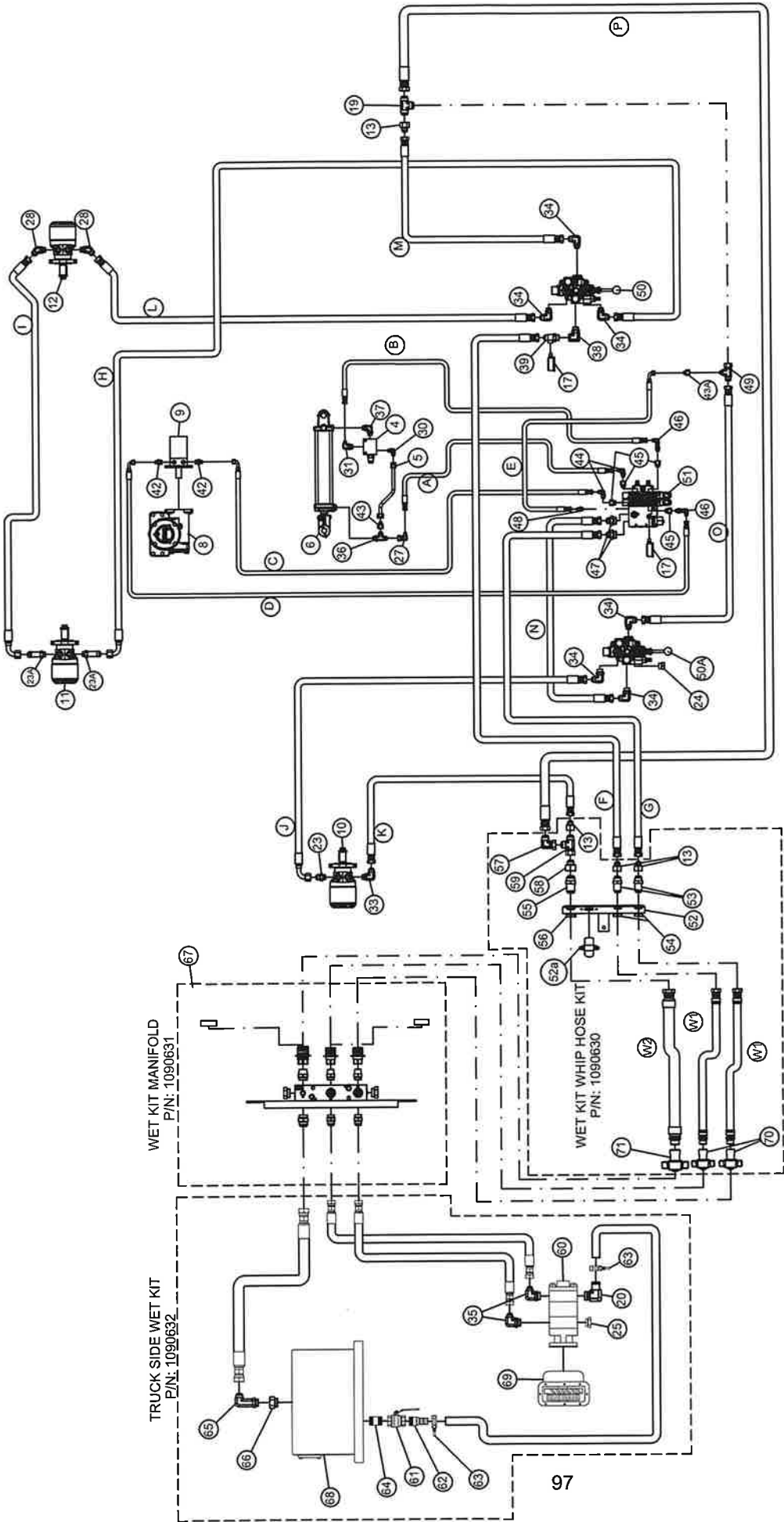

MT900WETLIST
REV 05/24/23

MT900 HYDRAULIC PLUMBING (TRAILER MOUNT WET KIT)(PARKER)

ITEM	PART NO.	DESCRIPTION	QTY	ITEM	PART NO.	DESCRIPTION	QTY
1		OMITTED		50	113237	SINGLE SPOOL VALVE	1
2		OMITTED		50A	1191269	SINGLE SPOOL VALVE (CLOSED)	1
3		OMITTED		51	1131625	DUAL SPOOL VALVE	1
4	1012830	COUNTER BALANCE LOCK (5:1 RATIO 2000 PSI)	1	52	76704	WET KIT MOUNTING ANGLE	1
5	100177A	FLARED CB TUBE	1	82-1041	SOCKET, TRAILER 2 POLE FEMALE	1	
6	47005491	HYDRAULIC CYLINDER (3 X 14)	1	53	2700-16-16	BULK HEAD UNION #16	2
7		OMITTED		54	306-16	NUT, LOCK BULK HEAD #16	2
8	1087194	GEAR BOX	1	55	2700-20-20	BULK HEAD UNION #20	1
9	1028801	MOTOR HYDRAULIC (GEAR BOX)	1	56	306-20	NUT, LOCK BULK HEAD #20	1
10	1040020	MOTOR HYDRAULIC (LOWER AUGER)	1	57	6500-16-16	ELBOW #16 MJIC X #16FJICS	1
11	1040045	MOTOR HYDRAULIC (DISCHARGE)	1	58	2406-20-16	FITTING #20 FJIC X #16 MJIC	1
12	1116558	MOTOR HYDRAULIC (VERTICAL)	1	59	6602-16-16-16	TEE #16 FJICS X #16 MJIC X #16 MJIC	1
13	2406-16-12	ADAPTER #16 FJIC X #12 MJIC	4(1/3)	60	1037666	HYDRAULIC PUMP	1
14		OMITTED		61	1084356	BALL VALVE, 1 1/2 NPT	1
15		OMITTED		62	1063538	NIPPLE, 1 1/2" NPT UNPLATED KING	1
16		OMITTED		63	1090239	CLAMP, 1 1/2" HOSE	2
17	25-901-SST-4000	4000 PSI PRESSURE GAUGE	2	64	1030868	HEX BUSHING	1
18		OMITTED		65	6801-LL-16-16	ELBOW EXTRA LONG #16 M O-RING X #16 MJIC	1
19	2603-16-16-12	TEE #16 MJIC X #16 MJIC X #12 MJIC	1	66	6410-20-16FRG-SHORT	ADAPTER #20 M O-RING X 16 F O-RING	1
20	4601-24-20	HOSE BARB 90°	1	67	1090631	WET KIT MANIFOLD (SEE NOTE)	1
21		OMITTED		68	1132734	OIL TANK	1
22		OMITTED		69		PTO ADAPTER (TO BE DETERMINED BY TRUCK)	1
23	6400-12-10W/S	ADAPTER 7/8 O-RING X #12 MJIC W/ SHOULDER	1	70	FA6125-16	WING COUPLER #16	2
24	6400-L-12-10	ADAPTER, LONG 7/8 O-RING X #12 MJIC	2	71	FA6125-20	WING COUPLER #20	1
25	6408-12	#12 O-RING PLUG	1				
26	6408-20	#20 O-RING PLUG	1				
27		OMITTED					
28	6500-06-08	ELBOW	1				
29	6802-12-10	ELBOW 45° #12 MJIC X #10 M O-RING	2				
30	6801-06-04	ELBOW #6 MJIC X #4 M O-RING	1				
31	6801-06-08	ELBOW #6 MJIC X #8 M O-RING	1				
32		OMITTED					
33	6801-12-10	3/4 X 5/8 O-RING STRAIGHT THD ELBOW	1				
34	6801-12-12	ELBOW #12 MJIC X #12 M O-RING	6				
35	6801-12-16	ELBOW #12 MJIC X #16 M O-RING	2				
36	6804-08-08-08	FITTING #8 MJIC X #8 MORB X #8 MJIC	1				
37	6807-08-08	ELBOW #8 MORB X #8 MORB	1				
38	6815-12-12	FITTING	1				
39	GP6400-12-12-4	GAUGE PORT ADAPTER	1				
40		OMITTED					
41		OMITTED					
42	6400-06-10	FITTING #6 MJIC X #10 M O-RING	2				
43	2406-08-06	FITTING #8 FJIC X #6 MJIC	1				
43A	2406-12-06	FITTING #12 FJIC X #6 MJIC	1				
44	6801-06-06	ELBOW 90° #6 MJIC X #6 M O-RING	2				
45	6410-08-06	ADAPTER #8 M O-RING X #6 F O-RING S	4				
46	6801-LL-06-06	ELBOW 90°, EXTRA LONG #6 MJIC X #6 M O-RING	2				
47	6400-12-16	ADAPTER, #12 MJIC X #16 M O-RING	2				
48	6400-06-06	ADAPTER, #6 MJIC X #6 M O-RING	1				
49	6602-12-12-12	TEE #12 MJIC X #12 FJICS X #12 MJIC	1				
REPLACEMENT SEAL KIT							
71779 FOR RAISE/ROTATE VALVE							
71788 FOR AUGER ENGAGEMENT VALVES							
ITEM 52 REQUIRES 18056824 (BOLT HEX CAP GR NC ZC 3/8 X 1 1/4) QTY 2 + 18496800 (NUT SER FLG 3/8 NC ZC) QTY 2 FOR MOUNTING							
FITTING KIT P/N: 1120446, INCLUDES ITEMS 5,13-19,23-24,27-34,36-39, & 42-49 (FITTING KIT INCLUDES 1 OF ITEM 13)							
HOSE KIT P/N: 1124063, INCLUDES HOSES A-E, H-I, AND L-O							
WET KIT WHIP HOSE KIT P/N: 1090630 INCLUDES HOSES W1-W2, ITEM 13 QTY 3, ITEMS 52 & 52A, 53-59, AND ITEMS 70-71							
WET KIT MANIFOLD P/N: 1090631 CONTAINS THE FOLLOWING: 1 EA OF: C11516 (MANIFOLD)/6401-20-20/6400-20-20/FA6105-20/FA6108-20/ FAM-WM-A -0001 (MTG BRKT) 2 EA OF: 6408-16/6401-16-16-16/6400-16-16/FA6105-16/FA6108-16							
TRUCK SIDE WET KIT P/N: 1090632 INCLUDES ITEMS #20, 25, 60-66 & 68-69							
REPLACEMENT HANDLES							
660150004 - SINGLE SPOOL HANDLE (AUGER ENGAGEMENT)							
1074373 - DUAL SPOOL HANDLE (ROTATE/LIFT)							

MT900 PLUMBING SCHEMATIC (TRAILER MOUNT - WET KIT) (EATON) MT900WET EATON
REV 09/12/23

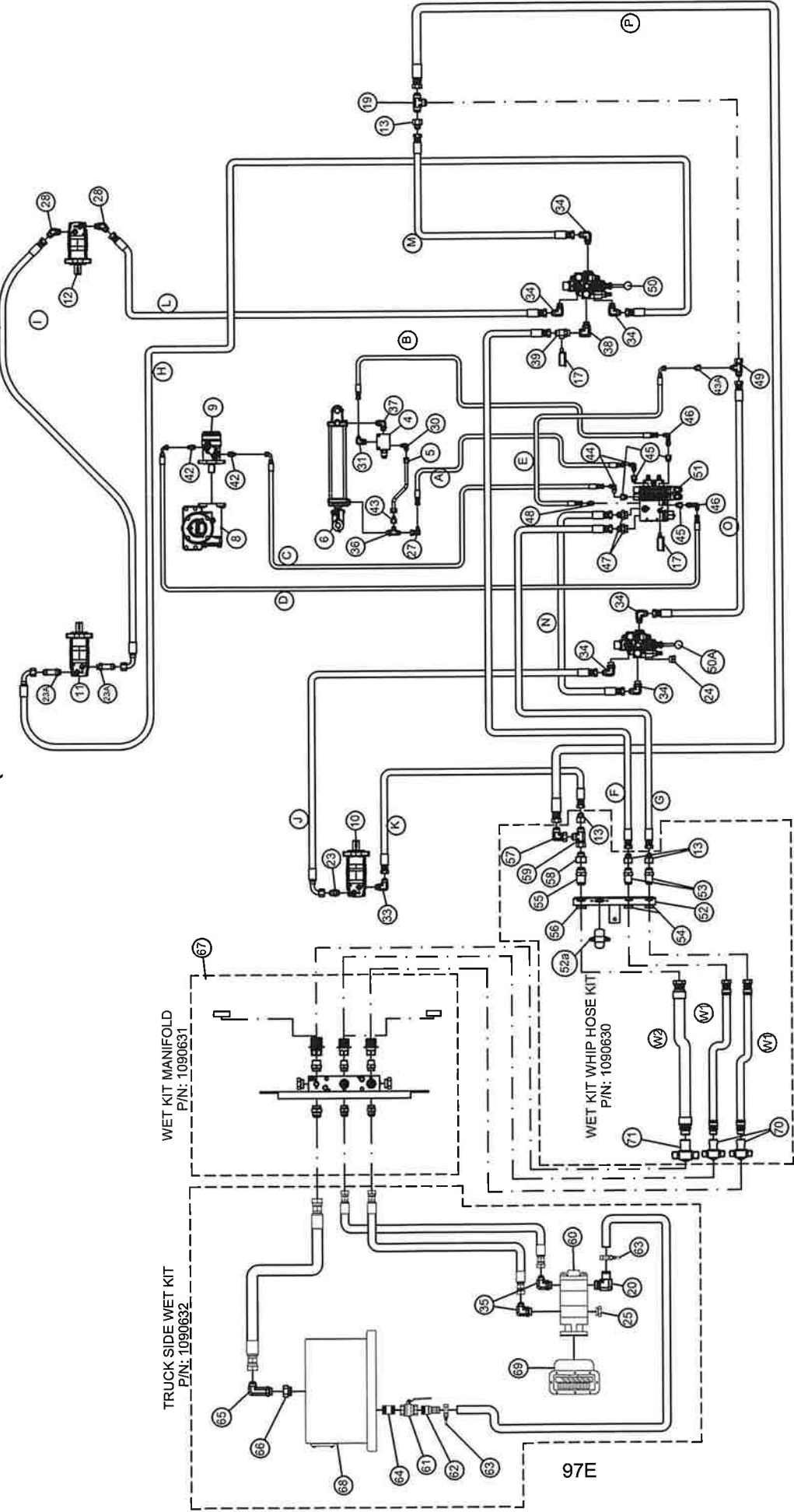

EATON MOTORS SUBSTITUTED FOR PARKER STARTING FALL 2023 SERIAL NUMBER 1120

MT900 HYDRAULIC PLUMBING (TRAILER MOUNT WET KIT) (EATON)

ITEM	PART NO.	DESCRIPTION	QTY	ITEM	PART NO.	DESCRIPTION	QTY
1	-	OMITTED	-	50	1132237	SINGLE SPOOL VALVE	1
2	-	OMITTED	-	50A	1191269	SINGLE SPOOL VALVE (CLOSED)	1
3	-	OMITTED	-	51	1131625	DUAL SPOOL VALVE	1
4	1012830	COUNTER BALANCE LOCK (5:1 RATIO 2000 PSI)	1	52	76704	WET KIT MOUNTING ANGLE	1
5	100177A	FLARED CB TUBE	1	52a	82-1041	SOCKET, TRAILER 2 POLE FEMALE	1
6	47005491	HYDRAULIC CYLINDER (3 X 14)	1	53	2700-16-16	BULK HEAD UNION #16	2
7	-	OMITTED	-	54	306-16	NUT, LOCK BULK HEAD #16	2
8	1087194	GEAR BOX	1	55	2700-20-20	BULK HEAD UNION #20	1
9	71891	MOTOR HYDRAULIC (GEAR BOX)	1	56	306-20	NUT, LOCK BULK HEAD #20	1
10	71892	MOTOR HYDRAULIC (LOWER AUGER)	1	57	6500-16-16	ELBOW #16 MJIC X #16 FJICS	1
11	71894	MOTOR HYDRAULIC (DISCHARGE)	1	58	2406-20-16	FITTING #20 FJIC X #16 MJIC	1
12	71893	MOTOR HYDRAULIC (VERTICAL)	1	59	6602-16-16-16	TEE #16 FJICS X #16 MJIC X #16 MJIC	1
13	2406-16-12	ADAPTER #16 FJIC X #12 MJIC	4(1/3)	60	1037666	HYDRAULIC PUMP	1
14	-	OMITTED	-	61	1084356	BALL VALVE, 1 1/2" NPT	1
15	-	OMITTED	-	62	1063538	NIPPLE, 1 1/2" NPT UNPLATED KING	1
16	-	OMITTED	-	63	1090239	CLAMP, 1 1/2" HOSE	2
17	25-901-SST-4000	4000 PSI PRESSURE GAUGE	2	64	1030868	HEX BUSHING	1
18	-	OMITTED	-	65	6801-LL-16-16	ELBOW EXTRA LONG #16 M O-RING X #16 MJIC	1
19	2603-16-16-12	TEE #16 MJIC X #16 MJIC X #12 MJIC	1	66	6410-20-16FRG-SHORT	ADAPTER #20 M O-RING X 16 F O-RING	1
20	4601-24-20	HOSE BARB 90°	1	67	1090631	WET KIT MANIFOLD (SEE NOTE)	1
21	-	OMITTED	-	68	1132734	OIL TANK	1
22	-	OMITTED	-	69	-	PTO ADAPTER (TO BE DETERMINED BY TRUCK)	1
23	6400-12-10W/S	ADAPTER 7/8 O-RING X #12 MJIC W/ SHOULDER	1	70	FA6125-16	WING COUPLER #16	2
23A	6400-L-12-10	ADAPTER, LONG 7/8 O-RING X #12 MJIC	2	71	FA6125-20	WING COUPLER #20	1
24	6408-12	#12 O-RING PLUG	1	HOSE	PART NO.	DESCRIPTION	QTY
25	6408-20	#20 O-RING PLUG	1	A	606155	3/8 HOSE X 155", #6 JICFS EA END	1
26	-	OMITTED	-	B	606144	3/8 HOSE X 144", #6 JICFS EA END	1
27	6500-06-08	ELBOW	1	C	606089	3/8 HOSE X 89", #6 JICFS X #6 JICFS 90°	1
28	6802-12-10	ELBOW 45° #12 MJIC X #10 M O-RING	2	D	606086	3/8 HOSE X 86", #6 JICFS X #6 JICFS 90°	1
29	-	OMITTED	-	E	606017	3/8 HOSE X 17", #6 JICFS X #6 JICFS 90°	1
30	6801-06-04	ELBOW #6 MJIC X #4 M O-RING	1	F	612424	3/4 HOSE X 424", #12 JICFS EA END	1
31	6801-06-08	ELBOW #6 MJIC X #8 M O-RING	1	G	612404	3/4 HOSE X 404", #12 JICFS EA END	1
32	-	OMITTED	-	H	612397	3/4 HOSE X 397", #12 JICFS X #12 JICFS 90°	1
33	6801-12-10	3/4 X 5/8 O-RING STRAIGHT THD ELBOW	1	I	612397	3/4 HOSE X 397", #12 JICFS X #12 JICFS 90°	1
34	6801-12-12	ELBOW #12 MJIC X #12 M O-RING	6	J	612280	3/4 HOSE X 280", #12 JICFS X #12 JICFS 90°	1
35	6801-12-16	ELBOW #12 MJIC X #16 M O-RING	2	K	612142	3/4 HOSE X 142", #12 JICFS EA END	1
36	6804-08-08-08	FITTING #8 MJIC X #8 MORB X #8 MJIC	1	L	622082	3/4 HOSE X 82", #12 JICFS EA END	1
37	6807-08-08	ELBOW #8 MORB X #8 MORB	1	M	612027	3/4 HOSE X 27", #12 JICFS EA END	1
38	6815-12-12	FITTING	1	N	612024	3/4 HOSE X 24", #12 JICFS EA END	1
39	GP6400-12-12-4	GAUGE PORT ADAPTER	1	O	612012	3/4 HOSE X 12", #12 JICFS X #12 JICFS 90°	1
40	-	OMITTED	-	P	616402	1 HOSE X 402", #16 JICFS EA END	1
41	-	OMITTED	-	S	-	SUCTION HOSE (#1 1/2 X TBD)	1
42	6400-06-10	FITTING #6 MJIC X #10 M O-RING	2	W1	622132	3/4 HOSE X 132", #16 JICFS X #16 MNPT	1
43	2406-08-06	FITTING #8 FJIC X #6 MJIC	1	W2	620132	1 1/4 HOSE X 132", #20 JICFS X #20 MNPT	2
43A	2406-12-06	FITTING #12 FJIC X #6 MJIC	1	FITTING KIT P/N: 1120446, INCLUDES ITEMS 5,13-19,23-24,27-34,36-39, & 42-49 (FITTING KIT INCLUDES 1 OF ITEM 13)			1
44	6801-06-06	ELBOW 90° #6 MJIC X #6 M O-RING	2	HOSE KIT P/N: 1124063, INCLUDES HOSES A-E, H-I, AND L-O			1
45	6410-08-06	ADAPTER #8 M O-RING X #6 F O-RING S	4	WET KIT WHIP HOSE KIT P/N: 1090630 INCLUDES HOSES W1-W2, ITEM 13 QTY 3, ITEMS 52 & 52A, 53-59, AND ITEMS 70-71			1
46	6801-LL-06-06	ELBOW 90° EXTRA LONG #6 MJIC X #6 M O-RING	2	WET KIT MANIFOLD P/N: 1090631 CONTAINS THE FOLLOWING:			1
47	6400-12-16	ADAPTER, #12 MJIC X #16 M O-RING	2	1 EA OF: C11516 (MANIFOLD)/6401-20-20/6400-20-20/FA6105-20/FA6108-20/FA6-WM-A -0001 (MTG BRKT)			1
48	6400-06-06	ADAPTER, #6 MJIC X #6 M O-RING	1	2 EA OF: 6408-16/6401-16-16/6400-16-16/FA6105-16/FA6108-16			1
49	6602-12-12-12	TEE #12 MJIC X #12 FJICS X #12 MJIC	1	TRUCK SIDE WET KIT P/N: 1090632 INCLUDES ITEMS #20, 25, 60-66 & 68-69			1

REPLACEMENT SEAL KIT
71779 FOR RAISE/ROTATE VALVE
71788 FOR AUGER ENGAGEMENT VALVES
ITEM 52 REQUIRES 1805824 (BOLT HEX CAP GR NC ZC 3/8 X 1 1/4) QTY 2 +
18496800 (NUT SER FLG 3/8 NC ZC) QTY 2 FOR MOUNTING

REPLACEMENT HANDLES
660150004 - SINGLE SPOOL HANDLE (AUGER ENGAGEMENT)
1074373 - DUAL SPOOL HANDLE (ROTATE/LIFT)

MT900 PLUMBING SCHEMATIC (BASIC)(PRE 2018)

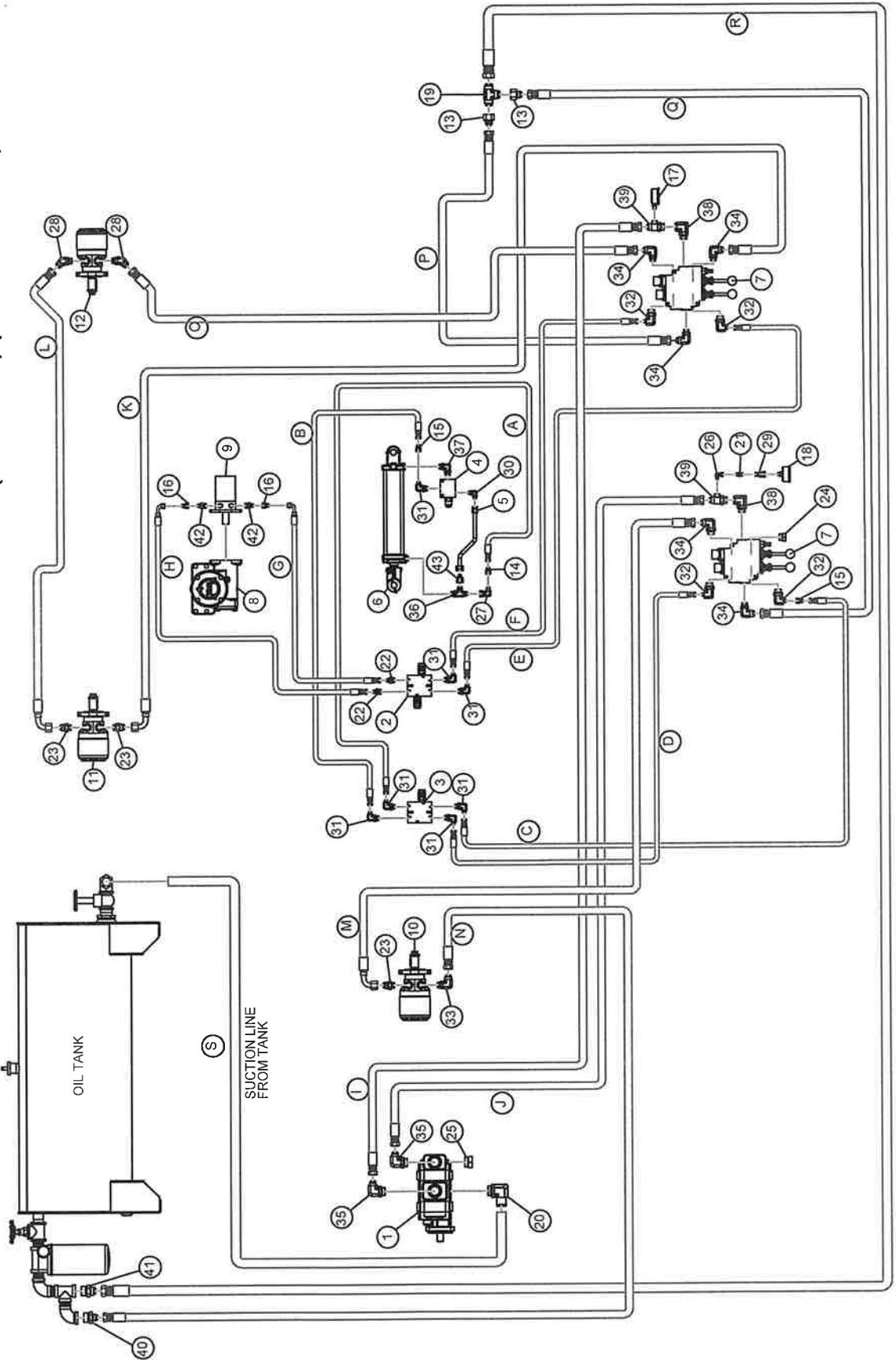

MT900 HYDRAULIC PLUMBING (BASIC)(PRE 2018)

<u>ITEM</u>	<u>PART NO.</u>	<u>DESCRIPTION</u>	<u>QTY</u>
1	MT900TAPUMP	HYDRAULIC PUMP (TWIN GEAR 27GPM @ 2600RPM)	1
2	1121679	ROTATE RELIEF BLOCK (800 PSI SETTING)	1
3	1121680	RAISE/LOWER RELIEF BLOCK (A500 PSI B PLUG)	1
4	1012830	COUNTER BALANCE LOCK (5:1 RATIO 2000 PSI)	1
5	100177	FLARED CB TUBE	1
6	47005491	HYDRAULIC CYLINDER (3 X 14)	1
7	1090702	CONTROL BLOCK (PRINCE VALVE)	2
8	1087194	GEAR BOX	1
9	1028801	MOTOR HYDRAULIC (GEAR BOX)	1
10	1040020	MOTOR HYDRAULIC (LOWER AUGER)	1
11	1040045	MOTOR HYDRAULIC (DISCHARGE)	1
12	1116558	MOTOR HYDRAULIC (VERTICAL)	1
13	2406-16-12	ADAPTER #16 FJIC X #12 MJIC	2
14	2406R-06-06-.047	FITTING 3/8 FJIC X 3/8 MJIC - .047 RESTRICT	1
15	2406R-06-06-.062	FITTING 3/8 FJIC X 3/8 MJIC - .062 RESTRICT	2
16	2406R-06-06-.094	FITTING 3/8 FJIC X 3/8 MJIC - .094 RESTRICT	2
17	25-901-SST-5000	5000 PSI PRESSURE GAUGE	1
18	25-911-5000PSI-KPA-14	5000 PSI PRESSURE GAUGE REAR MOUNT	1
19	2603-16-16-16	TEE #16 MJIC	1
20	4601-24-20	HOSE BARB 90°	1
21	6400-04-04	FITTING #4 MJIC X #4 MORB	1
22	6400-06-08	FITTING #6 MJIC X #8 M O-RING	2
23	6400-12-10W/S	ADAPTER 7/8 O-RING X #12 MJIC W/ SHOULDER	3
24	6408-12	#12 O-RING PLUG	1
25	6408-20	#20 O-RING PLUG	1
26	6500-04-04	ELBOW #4 MJIC X #4 FJICS	1
27	6500-06-08	ELBOW	1
28	6802-12-10	ELBOW 45° #12 MJIC X #10 M O-RING	2
29	6506-04-04	FITTING #4 FJICS X #4 NPT	1
30	6801-06-04	ELBOW #6 MJIC X #4 M O-RING	1
31	6801-06-08	ELBOW #6 MJIC X #8 M O-RING	7
32	6801-06-12	ELBOW #6 MJIC X #12 M O-RING	4
33	6801-12-10	3/4 X 5/8 O-RING STRAIGHT THD ELBOW	1
34	6801-12-12	ELBOW #12 MJIC X #12 M O-RING	5
35	6801-12-16	ELBOW #12 MJIC X #16 M O-RING	2
36	6804-08-08-08	FITTING #8 MJIC X #8 MORB X #8 MJIC	1
37	6807-08-08	ELBOW #8 MORB X #8 MORB	1
38	6815-12-12	FITTING	2
39	GP6400-12-12-4	GAUGE PORT ADAPTER	2
40	2404-12-20	ADAPTER 1 1/4 NPT M X #12 MJIC	1
41	2404-16-20	ADAPTER 1 1/4 NPT M X #16 MJIC	1
42	6400-06-10	FITTING #6 MJIC X #10 M O-RING	2
43	2406-08-06	FITTING #8 FJIC X #6 MJIC	1
<u>HOSE</u>	<u>PART NO.</u>	<u>DESCRIPTION</u>	<u>QTY</u>
A	606100	3/8 HOSE X 100", #6 JICFS EA END	1
B	606088	3/8 HOSE X 88", #6 JICFS EA END	1
C	606061	3/8 HOSE X 61", #6 JICFS EA END	1
D	606052	3/8 HOSE X 52", #6 JICFS EA END	1
E	606051	3/8 HOSE X 51", #6 JICFS EA END	1
F	606047	3/8 HOSE X 47", #6 JICFS EA END	1
G	606039	3/8 HOSE X 39 1/2", #6 JICFS X #6 JICFS 90°	1
H	606036	3/8 HOSE X 36 1/2", #6 JICFS X #6 JICFS 90°	1
I	612424	3/4 HOSE X 424", #12 JICFS EA END	1
J	612404	3/4 HOSE X 404", #12 JICFS EA END	1
K	612397	3/4 HOSE X 397", #12 JICFS X #12 JICFS 90°	1
L	612397	3/4 HOSE X 397", #12 JICFS X #12 JICFS 90°	1
M	612287	3/4 HOSE X 287", #12 JICFS X #12 JICFS 90°	1
N	612142	3/4 HOSE X 142", #12 JICFS EA END	1
O	622082	3/4 HOSE X 82", #12 JICFS EA END	1
P	612027	3/4 HOSE X 27", #12 JICFS EA END	1
Q	612016	3/4 HOSE X 16", #12 JICFS EA END	1
R	616394	1 HOSE X 394", #16 JICFS EA END	1
S	12003501	SUCTION HOSE (ø1 1/2 X 22 3/8 LG)	1

TARP END CAP SUPPORT MOUNTING ILLUSTRATION

ITEM NO.	PART NUMBER	DESCRIPTION	QTY
2	WJ100X0	TARP END CAP (SUPPLIED W/ TARP)	2
3	76747	CAP SUPPORT	4
4	18706621CS	SCREW, SLOTTED TRUSS HEAD 3/8 X 3/4 SS(SUPPLIED WITH TARP)	8
5	18987900CS	NUT SER FLG SS 3/8 (SUPPLIED WITH TARP)	8
6	18026822	BOLT, HEX HD 3/8 X 1 NC SS	8
7	18991200	WASHER FLAT 3/8 SS	8
8	18881201	WASHER LOCK 3/8 SS	8
9	18476800	NUT 3/8 SS	8

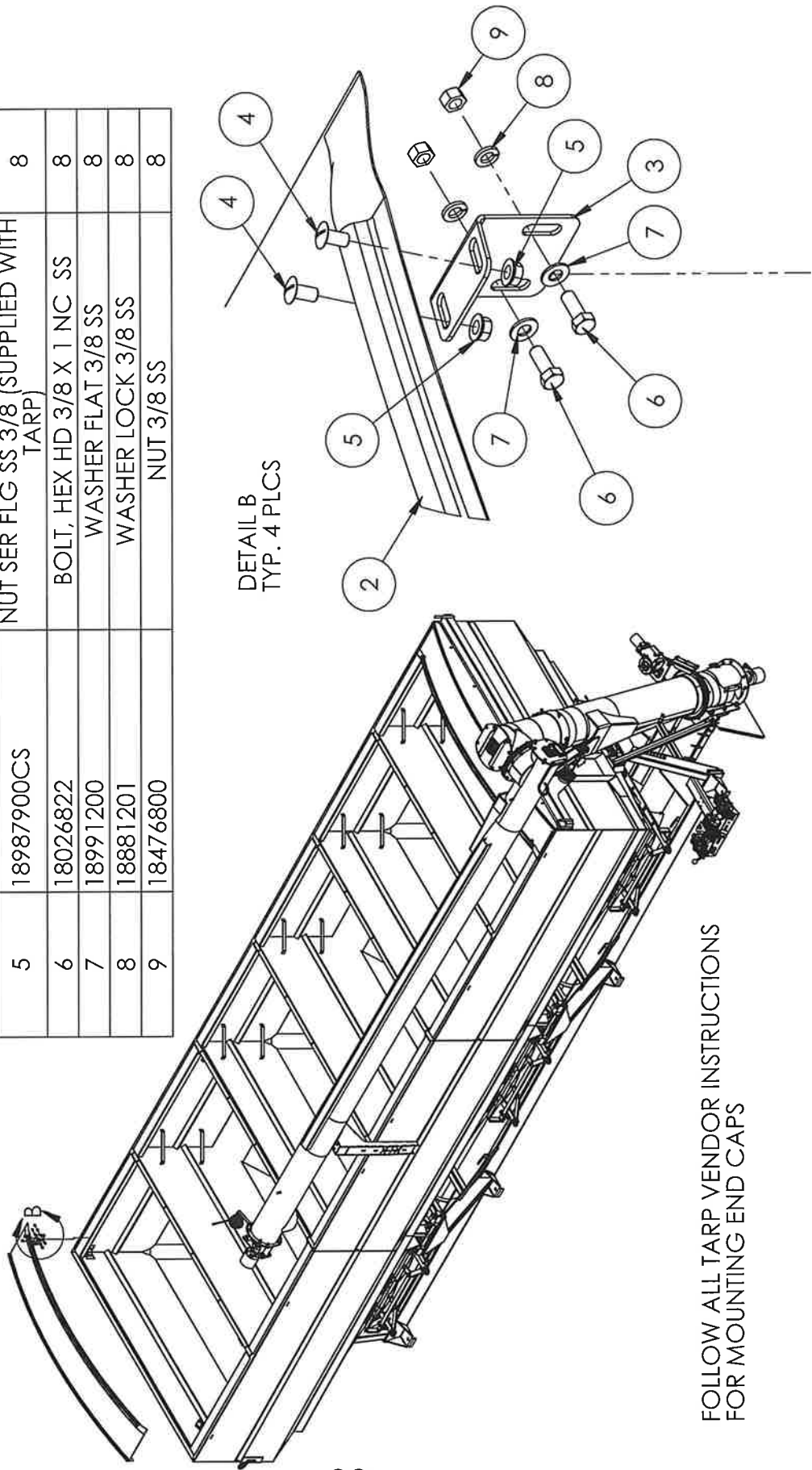

FOLLOW ALL TARP VENDOR INSTRUCTIONS
FOR MOUNTING END CAPS

ARCH DIVIDER LAYOUT & PARTS LISTING

ITEM NO.	PART NUMBER	DESCRIPTION	MT900 QTY	MT600 QTY
2	47076758	FORMED BOW WLDMT	5	3
3	18706621	SCREW, SLOTTED TRUSS HEAD 3/8 X 3/4 SS	25	15
4	18987900	NUT SER FLG SS 3/8	25	15

ARCH DIVIDER COMPLETE KIT MT600 P/N: **47986758**
 ARCH DIVIDER COMPLETE KIT MT900 P/N: **47996758**
 (does not include cover, end caps, stationary tubes and opener w/ electric motor)

To order the cover, end caps, stationary tubes, and opener w/ electric motor, use the following:

MT600 - P/N: **SRT-AGS 4002854**
 MT900 - P/N: **SRT-AGS 4002855**

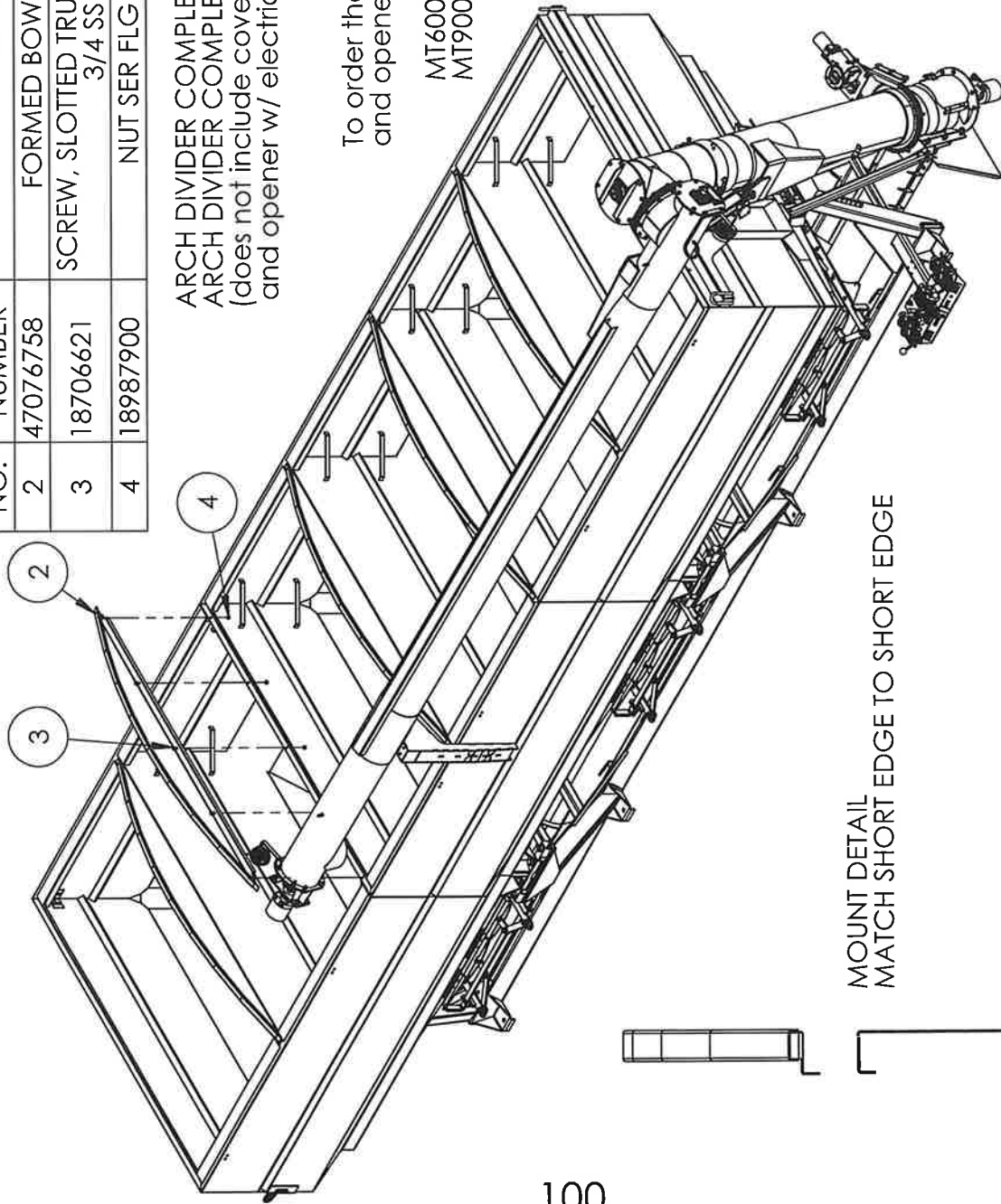

Agri-Cover Inc

SRT-2® SPOOL ROLL TARP COMPONENTS

10/16/2017

Ag Systems MT-900

TARP **BOX SIZE** **FINISHED TARP WIDTH AND LENGTH**
 100" x 25' (300") FTW 114" X FTL 288" Black, 7" rise

Serial Number SB 012466 Black

BOWS AND HARDWARE (TOP MOUNT)

Item	Part #	Max. Box Width (all 7" rise)	Qty
1	JL100202	100" Bow Assy w/ Extension, Stainless Steel, Std Rise	6
3	HN100202	100" Bow, Stainless Steel, Std Rise	6
4	30660	Bow Extension Stainless Steel	6
5	10927	Bolt, 3/8" x 1" Gr 5, Stainless Steel, (3) Required per Bow	18
6	10930	Washer, Flat 3/8" Stainless Steel, (2) Required per Bow	12
7	10929	Washer, Lock 3/8" Stainless Steel, (2) Required per Bow	12
8	10928	Nut, 3/8" Stainless Steel, (2) Required per Bow	12
	50585	Bow Hardware Kit Stainless Steel (bolts, nuts & washers), (1) per Bow	6

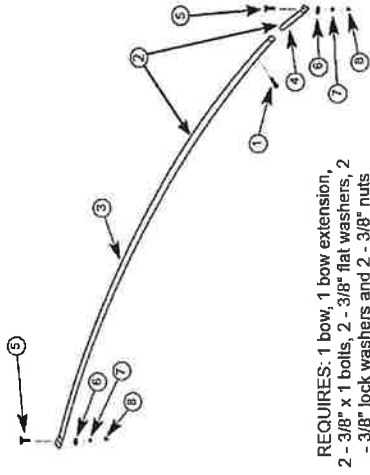

END CAP (TOP MOUNT 7" RISE)

Item	Top Mount Part #	Max. Box Width	Qty
1	WK10020	100" End Cap, Stainless Steel, Std Rise	2

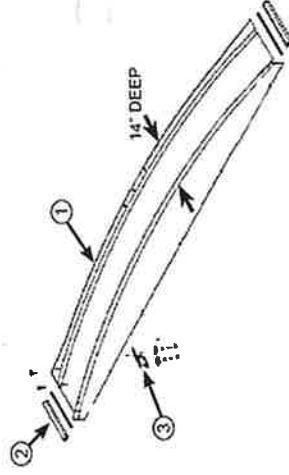

END CAP HARDWARE

Item	Part #	Description	Qty
2	60242	End Cap Seal, 60" Long (for 2 end caps)	1
3	30689	End Cap Bracket Kit 7" Rise Stainless Steel (for 2 end caps)	2

CABLES

Item	Part #	Description	Qty
1	10941	Cable 139" Stainless Steel (up to 102" wide box)	2

SPOOLS

Item	Part #	Description	Qty
2	20547	Spool, Left Front 3" Nylon (up to 120" wide box) (Greased)	1
3	20548	Spool, Right Rear 3" Nylon (up to 120" wide box) (Greased)	1
	30655	Spool Grease (3/4 oz. tube, Teflon Grease)	1
4	30553	O-Ring Kit (includes 2 rubber rings)	1

SPRINGS

Item	Part #	Description	Qty
5	40983	Spring Front Powder Coated Black (for stainless steel kits)	1
6	40982	Spring Rear Powder Coated Red (for stainless steel kits)	1

CARTRIDGES

Item	Part #	Description	Qty
7	40961	Bolt, Carriage 5/16" x 1" Zinc Plated	2
8	10331	Cartridge Clamp (for Galvanized & Stainless Steel Systems)	2
9	60067	Nut, Hex Nyloc 5/16" Zinc Plated	2
10	10607	Powder Coated Cartridge (front left)	1
11	10608	Powder Coated Cartridge (rear right)	1
12	50600	PVC Spacer, Bolt & Nut Kit (for stainless steel)	2

CABLE RATCHET AND STRAP (1" WIDE)

Item	Part #	Description	Qty
1	70989	Ratchet Strap Short w/ Stainless Steel Hook (1")	2
2	71004	Bracket Adjustable Stainless Steel	2
3	80033	Ratchet Only Stainless Steel	2
4	10927	Bolt, 3/8" x 1" Gr 5, Stainless Steel, 2 Required	4
5	10928	Nut, 3/8" Stainless Steel	4
6	10929	Washer, Lock 3/8" Stainless Steel	4
7	10930	Washer, Flat 3/8" Stainless Steel	4

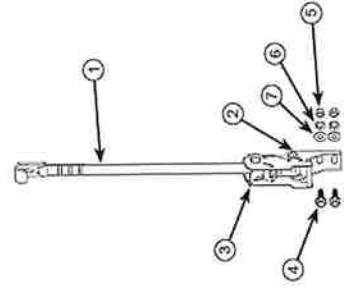
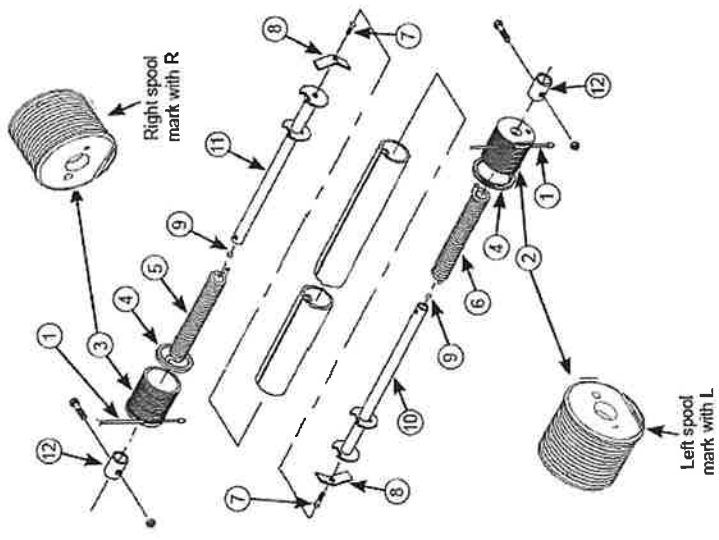

3" ROLL TUBE AND SPLICE (ALUMINUM)

Item	Part #	Description	Qty
3	10263	Roll Tube 3" Dia. Aluminum (price per lin. inch)	294"
4	50064	Splice Tube, 24" Long Aluminum (for 3" dia. roll tube)	0
	60786	Drive Rivet, 3/16" x 1/4" (black, attaches tarp to roll tube)	2
5	60640	Screw, Phillips Head Self Drilling, 1/4" x 3/4"	1



1" STATIONARY TUBE (STEEL)

Item	Part #	Description	Qty
6	60793	Drive Rivet, 3/16" x 1/8" (silver, attaches tarp to stationary tube)	2
7	20905	1" Dia. Stationary Tube Stainless Steel (price per lin. inch)	289"
8	50555	Tube End Plug 1" Dia. (2 pcs.) Stainless Steel	1
9	60976	1" Dia. Stationary Tube Splice	0

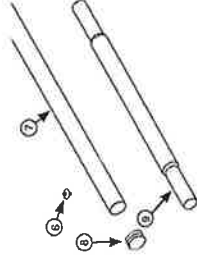

RIDGE STRAP ASSEMBLY (1" WIDE)

Item	Part #	Description	Qty
	70557	Ridge Strap Kit, Stainless Steel up to 36' Long Box	1

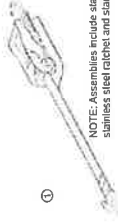

NOTE: Assemblies include standard webbing, stainless steel ratchet and stainless steel hook.

TARP STOP (STAINLESS STEEL)

Item	Part #	Description	Qty
2	70334	Powder Coated Quick Release Tarp Stop No Leg Only (for stainless steel kits)	2
4	70332	Powder Coated Quick Release Tarp Stop (tall leg w/ set screw)	2
6	90241	Clevis Pin, Stainless Steel	8
7	90248	Bow Tie Pin, Stainless Steel	8
8	70282	Stainless Steel Base for Quick Release Tarp Stop	4
9	10927	Bolt, 3/8" x 1" Gr 5, Stainless Steel, 2 Required	12
12	10928	Nut, 3/8" Stainless Steel	12
13	10929	Washer, Lock 3/8" Stainless Steel	12
	10930	Washer, Flat 3/8" Stainless Steel	12

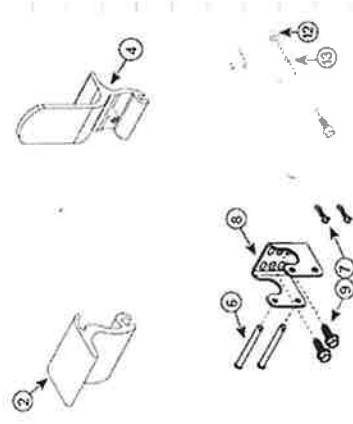

ELECTRIC MOTOR , SRT-2 (STAINLESS STEEL)

Item	Part #	Description	Qty
1	50676	Motor, 12V w/ Cover (SRT-2)	1
	4000540	Motor Switch Box Kit	1
	90161	Motor Cover (w/ hardware)	1
2	10333	Motor Extension Shaft, 14" Powder Coat (SRT-2)	1
3	10774	Pivot Arm Top, 30" w/ Motor Mount	1
4	40941	Bolt, 5/16" x 3/4" Stainless Steel (requires 3 for motor mount)	3
5	10922	Washer, Lock 5/16" Stainless Steel (requires 3 for motor mount)	3
6	10124	Plug, Nylon	1
7	10925	Bolt, 5/16" x 1-3/4" Hex, Stainless Steel	1
8	10924	Nut, 5/16" Hex Rev-Lock Stainless Steel	1
9	40989	Pivot Arm, Bottom Stainless Steel (60")	1
10	4000083	Bolt, 3/8" x 4" Hex, Stainless Steel	1
11	60451	Nut, 3/8" Hex Stainless Steel	3

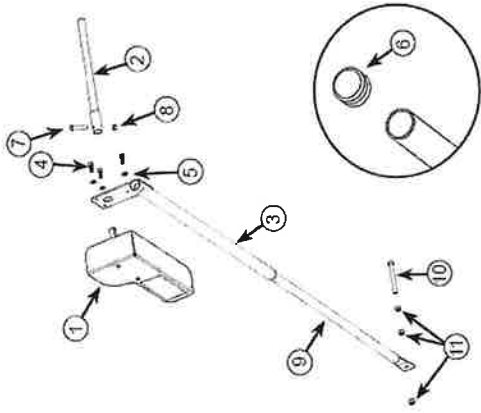

ELECTRIC WIRING

Item	Part #	Description	Qty
7	30314	Eyelet Terminal Ring 6 Ga. 1/2" for Battery Post (+)	1
8	30313	Eyelet Terminal Ring 6 Ga. 3/8" for Battery Post (-)	1
11	70278	Terminal Boots, Lug Type 8 - 2 Ga.	2
12	30649	Heat Shrink Kit 10 Pcs.	10
17	20046	Wire, 6 Ga. 2 Strand (price per lin. ft.)	30
18	30647	Eyelet Terminal Ring 6 Ga. #10 (for automatic breaker)	2

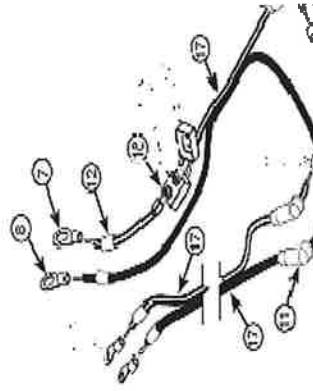

AGRI-COVER SWITCH AND REMOTE CONTROL

Item	Part #	Description
1	4000703	AGRI-COVER Switch and Remote Control Kit
2	4000702	Wireless Switch Control Receiver
3	4000711	AGRI-COVER Remote Control
4	4000715	A23 Battery, 12V
5	70929	Dielectric Grease Packet
6	4000542	Butt Connector
7	80285	Circuit Breaker, Automatic 12V 50 Amp
8	4000535	Adhesive Lined Heat Shrink
9	4000543	Bolt, Hex, 1/4-20 X 1 3/4, SST 18-8, Full Thread
10	60987	Washer, Flat 1/4", Stainless Steel
11	50615	Washer, Lock 1/4", Stainless Steel
14	80809	Nut, Hex 1/4-20", Stainless Steel
	4000532	Strain Relief

QUANTITY

- 1
- 1
- 1
- 1
- 1
- 4
- 1
- 4
- 4
- 4
- 4
- 4
- 4

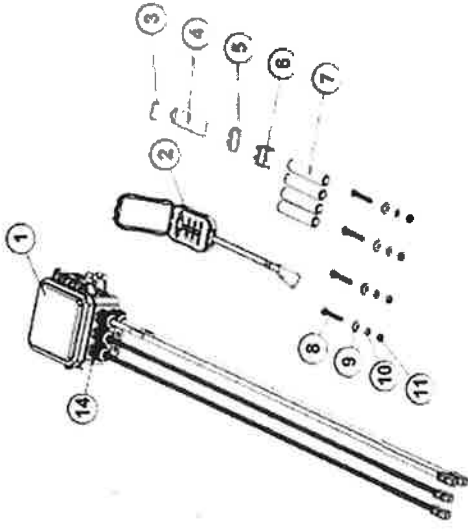

Agri-Cover Inc
SRT-2® SPOOL ROLL TARP COMPONENTS
 10/16/2017 Ag Systems MT-600

TARP BOX SIZE FINISHED TARP WIDTH AND LENGTH
 100" x 16' 8" (200" FTW 114" X FTL 188" Black, 7" rise
 Serial Number SB-011011 Black

BOWS AND HARDWARE (TOP MOUNT)

Item	Part #	Max. Box Width (all 7" rise)	Qty
1	JL100202	100" Bow w/ Extension, Stainless Steel, Std Rise	4
3	HN100202	100" Bow, Stainless Steel, Std Rise	4
4	30660	Bow Extension Stainless Steel	4
5	10927	Bolt, 3/8" x 1" Gr 5, Stainless Steel, (3) Required per Bow	12
6	10930	Washer, Flat 3/8" Stainless Steel, (2) Required per Bow	8
7	10929	Washer, Lock 3/8" Stainless Steel, (2) Required per Bow	8
8	10928	Nut, 3/8" Stainless Steel, (2) Required per Bow	8
	50585	Bow Hardware Kit Stainless Steel (bolts, nuts & washers), (1) per Bow	4

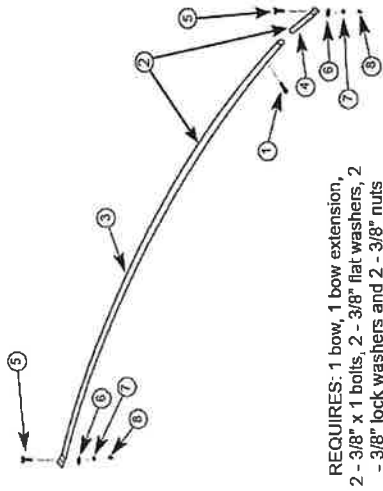

END CAP (TOP MOUNT 7" RISE)

Item	Top Mount Part #	Max. Box Width	Qty
1	WK10020	100" End Cap, Stainless Steel, Std Rise	2

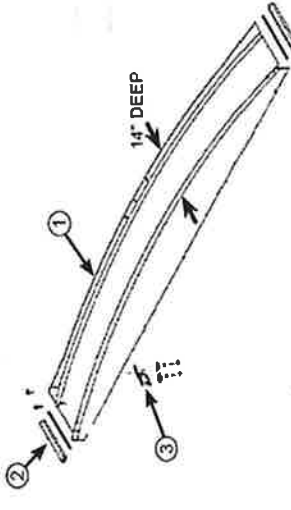

END CAP HARDWARE

Item	Part #	Description	Qty
2	60242	End Cap Seal, 60" Long (for 2 end caps)	1
3	30689	End Cap Bracket Kit 7" Rise Stainless Steel (for 2 end caps)	2

3" ROLL TUBE AND SPLICE (ALUMINUM)

Item	Part #	Description	Qty
3	10263	Roll Tube 3" Dia. Aluminum (price per lin. inch)	194"
4	50064	Splice Tube, 24" Long Aluminum (for 3" dia. roll tube)	0
	60786	Drive Rivet, 3/16" x 1/4" (black, attaches tarp to roll tube)	2
5	60640	Screw, Phillips Head Self Drilling, 1/4" x 3/4"	1

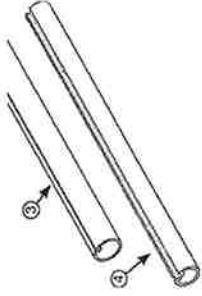

1" STATIONARY TUBE (STEEL)

Item	Part #	Description	Qty
6	60793	Drive Rivet, 3/16" x 1/8" (silver, attaches tarp to stationary tube)	2
7	20905	1" Dia. Stationary Tube Stainless Steel (price per lin. inch)	189"
8	50555	Tube End Plug 1" Dia. (2 pcs.) Stainless Steel	1
9	60976	1" Dia. Stationary Tube Splice	0

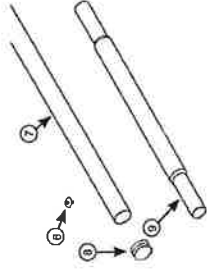

RIDGE STRAP ASSEMBLY (1" WIDE)

Item	Part #	Description	Qty
	40963	Ridge Strap Kit, Stainless Steel up to 18' Long Box	1



TARP STOP (STAINLESS STEEL)

Item	Part #	Description	Qty
2	70334	Powder Coated Quick Release Tarp Stop No Leg Only (for stainless steel kits)	1
4	70332	Powder Coated Quick Release Tarp Stop (tall leg w/ set screw)	2
6	90241	Clevis Pin, Stainless Steel	6
7	90248	Bow Tie Pin, Stainless Steel	6
8	70282	Stainless Steel Base for Quick Release Tarp Stop	3
9	10927	Bolt, 3/8" x 1" Gr 5, Stainless Steel, 2 Required	10
12	10928	Nut, 3/8" Stainless Steel	10
13	10929	Washer, Lock 3/8" Stainless Steel	10
	10930	Washer, Flat 3/8" Stainless Steel	10

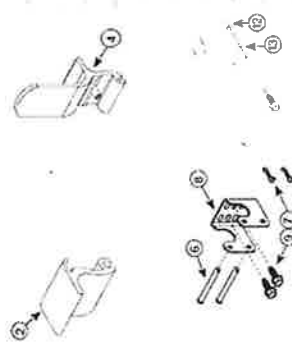

CABLES

Item	Part #	Description	Qty
1	10941	Cable 139" Stainless Steel (up to 102" wide box)	2

SPOOLS

Item	Part #	Description	Qty
2	20547	Spool, Left Front 3" Nylon (up to 120" wide box) (Greased)	1
3	20548	Spool, Right Rear 3" Nylon (up to 120" wide box) (Greased)	1
4	30655	Spool Grease (3/4 oz. tube, Teflon Grease)	1
5	30553	O-Ring Kit (includes 2 rubber rings)	1

SPRINGS

Item	Part #	Description	Qty
5	40983	Spring Front Powder Coated Black (for stainless steel kits)	1
6	40982	Spring Rear Powder Coated Red (for stainless steel kits)	1

CARTRIDGES

Item	Part #	Description	Qty
7	40961	Bolt, Carriage 5/16" x 1" Zinc Plated	2
8	10331	Cartridge Clamp (for Galvanized & Stainless Steel Systems)	2
9	60067	Nut, Hex Nyloc 5/16" Zinc Plated	2
10	10607	Powder Coated Cartridge (front left)	1
11	10608	Powder Coated Cartridge (rear right)	1
12	50600	PVC Spacer, Bolt & Nut Kit (for stainless steel)	2

CABLE RATCHET AND STRAP (1" WIDE)

Item	Part #	Description	Qty
1	70989	Ratchet Strap Short w/ Stainless Steel Hook (1")	2
2	71004	Bracket Adjustable Stainless Steel	2
3	80033	Ratchet Only Stainless Steel	2
4	10927	Bolt, 3/8" x 1" Gr 5, Stainless Steel, 2 Required	4
5	10928	Nut, 3/8" Stainless Steel	4
6	10929	Washer, Lock 3/8" Stainless Steel	4
7	10930	Washer, Flat 3/8" Stainless Steel	4

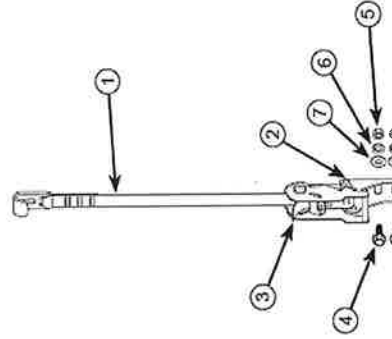
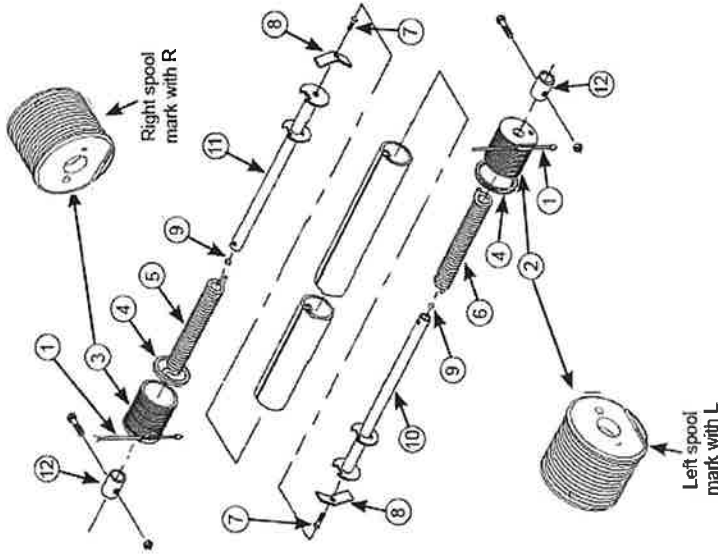

ELECTRIC MOTOR, SRT-2 (STAINLESS STEEL)

Item	Part #	Description
1	50676	Motor, 12V w/ Cover (SRT-2)
	4000540	Motor Switch Box Kit
	90161	Motor Cover (w/ hardware)
2	10333	Motor Extension Shaft, 14" Powder Coat (SRT-2)
3	10774	Pivot Arm Top, 30" w/ Motor Mount
4	40941	Bolt, 5/16" x 3/4" Stainless Steel (requires 3 for motor mount)
5	10922	Washer, Lock 5/16" Stainless Steel (requires 3 for motor mount)
6	10124	Plug, Nylon
7	10925	Bolt, 5/16" x 1-3/4" Hex, Stainless Steel
8	10924	Nut, 5/16" Hex Rev-Lock Stainless Steel
9	40989	Pivot Arm, Bottom Stainless Steel (60")
10	4000083	Bolt, 3/8" x 4" Hex, Stainless Steel
11	60451	Nut, 3/8" Hex Stainless Steel

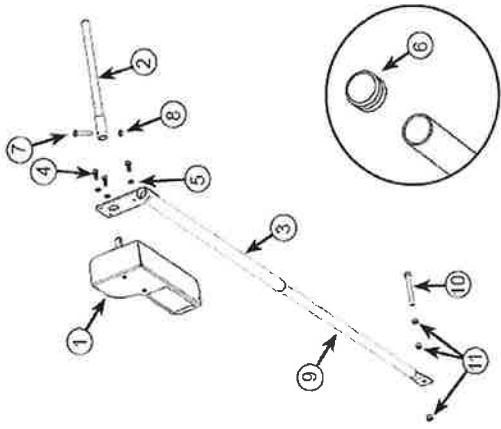

Qty
1
1
1
1
1
3
3
1
1
1
1
1
3

ELECTRIC WIRING

Item	Part #	Description
7	30314	Eyelet Terminal Ring 6 Ga. 1/2" for Battery Post (+)
8	30313	Eyelet Terminal Ring 6 Ga. 3/8" for Battery Post (-)
11	70278	Terminal Boots, Lug Type 8 - 2 Ga.
12	30649	Heat Shrink Kit 10 Pcs.
17	20046	Wire, 6 Ga. 2 Strand (price per lin. ft.)
18	30647	Eyelet Terminal Ring 6 Ga. #10 (for automatic breaker)

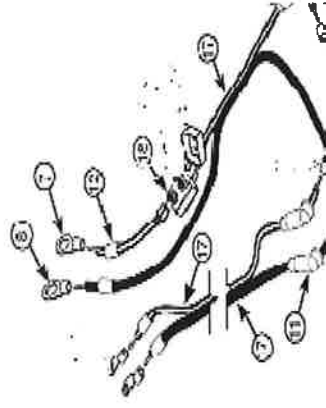

Qty
1
1
2
10
30
2

AGRI-COVER SWITCH AND REMOTE CONTROL

Item	Part #	Description
1	4000703	AGRI-COVER Switch and Remote Control Kit
2	4000702	Wireless Switch Control Receiver
3	4000711	AGRI-COVER Remote Control
4	4000715	A23 Battery, 12V
5	70929	Dielectric Grease Packet
6	4000542	Built Connector
7	80285	Circuit Breaker, Automatic 12V 50 Amp
8	4000535	Adhesive Lined Heat Shrink
9	4000543	Bolt, Hex, 1/4-20 X 1 3/4, SST 18-8, Full Thread
10	60987	Washer, Flat 1/4", Stainless Steel
11	50615	Washer, Lock 1/4", Stainless Steel
14	80809	Nut, Hex 1/4-20", Stainless Steel
	4000532	Strain Relief

QUANTITY

- 1
- 1
- 1
- 1
- 1
- 4
- 1
- 4
- 4
- 4
- 4
- 4
- 4
- 4

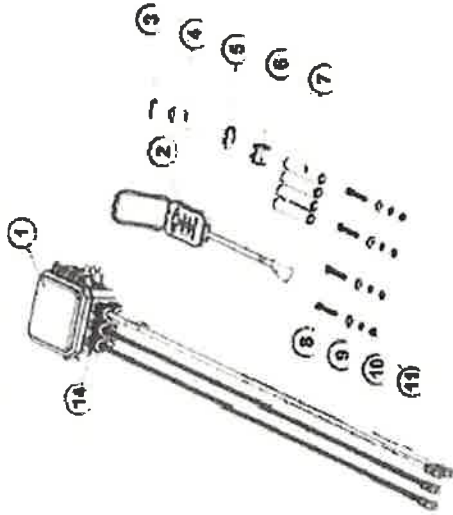

**2018 AND NEWER SWITCH KIT
PART NUMBER 4003597**

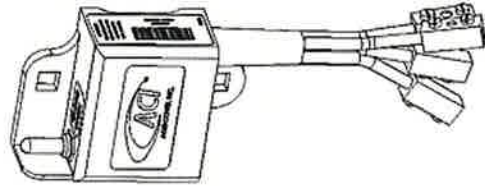

MT900 VIBRATOR PACKAGE PARTS LIST

(P/N: 4703DC700 - LOOSE / 4703DC700A - ASSEMBLED)

ITEM NO.	PART NUMBER	DESCRIPTION	QTY.
1	47076070	HOPPER WELDMENT	1
2	76737	VIBRATOR SWITCH PLATE	3
3	18476351	NUT HX SS 5/16 SELF LOCK	6
4	CG-100451	SWITCH (INCLUDED WITH VIBRATOR)	3
5	18704218	SCREW MACH RD PH SS 8-32 X 3/4 LG	12
6	18474201	NUT HX NYLOCK #8-32 SS	12
7	MDCV12-700-MM-96-06	VIBRATOR	3
8	735320	TRAILER WIRE 12 GA/2	3
9	195569-86	CORD EXTENSION 86" (INCLUDED W/ VIBRATOR)	3
10	18097540	BOLT, HEX CAP 1/2-13 X 4 1/2 LG GRADE 8 ZC	6
11	18851400	WASHER FLAT 1/2 SAE ZC	6
12	18457400	NUT, NYLOCK 1/2-13 GRADE 8 ZC	6
13	47007997	VIBRATOR MOUNT	3

REF. ONLY

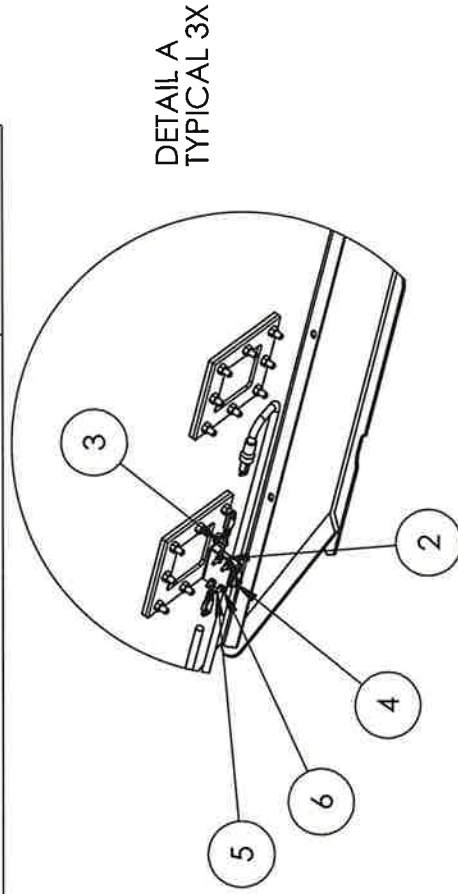
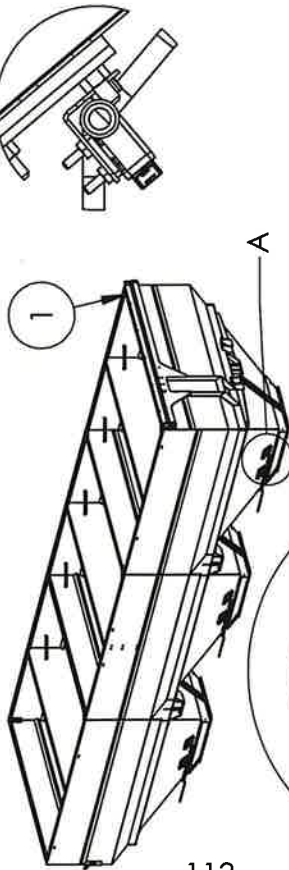

DETAIL A
TYPICAL 3X

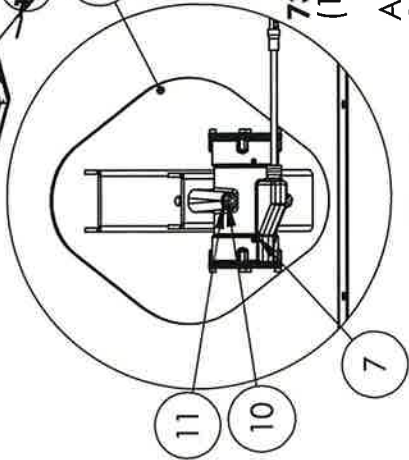

DETAIL B
TYPICAL 3X

REPLACEMENT PARTS:

CG-100454 - FUSE 20 AMP

735320 - 12 GA/2 WIRE- QTY 67 1/2'
(1- 14' / 1-22 1/2' / 1-31')

ALSO REQ'D BUT NOT SHOWN:

32504 - VINYL INSULATED RINGS - QTY 3

38262 - STEP DOWN BUTT CONNECTORS - QTY 3

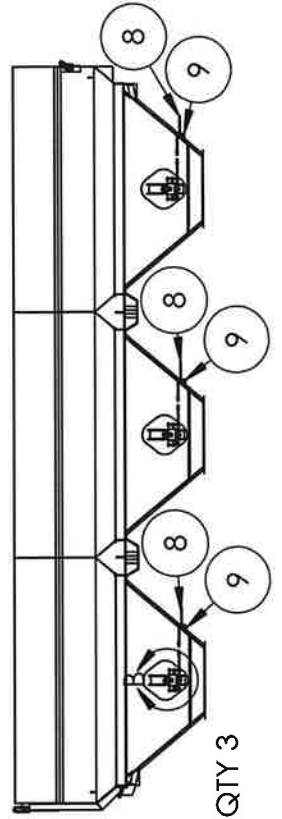

MT900 VIBRATOR WIRING DIAGRAM

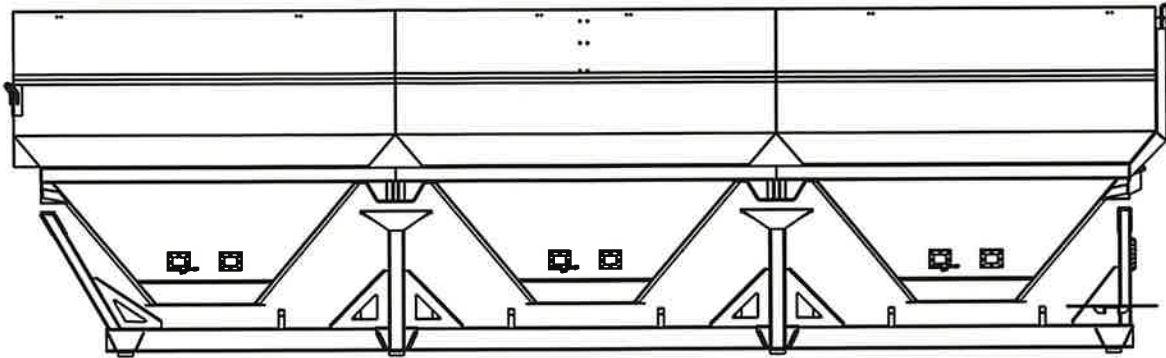

1. CABLES SHOWN IN MARKED "A", ARE PREASSEMBLED TO THE VIBRATOR
2. CUT THE PLUG END OFF THE END OF THE SWITCH HEADED TO THE BATTERY
3. ATTACH P/N 38262 (STEP DOWN BUTT CONNECTOR) TO SNIPPED END
4. INSERT CUT TO LENGTH WIRE INTO THE OPEN END OF BUTT CONNECTOR AND SEAL
5. REPEAT FOR ALL VIBRATORS
6. SEND P/N 32504 VINYL INSULATED RINGS LOOSE

TO BATTERY
←

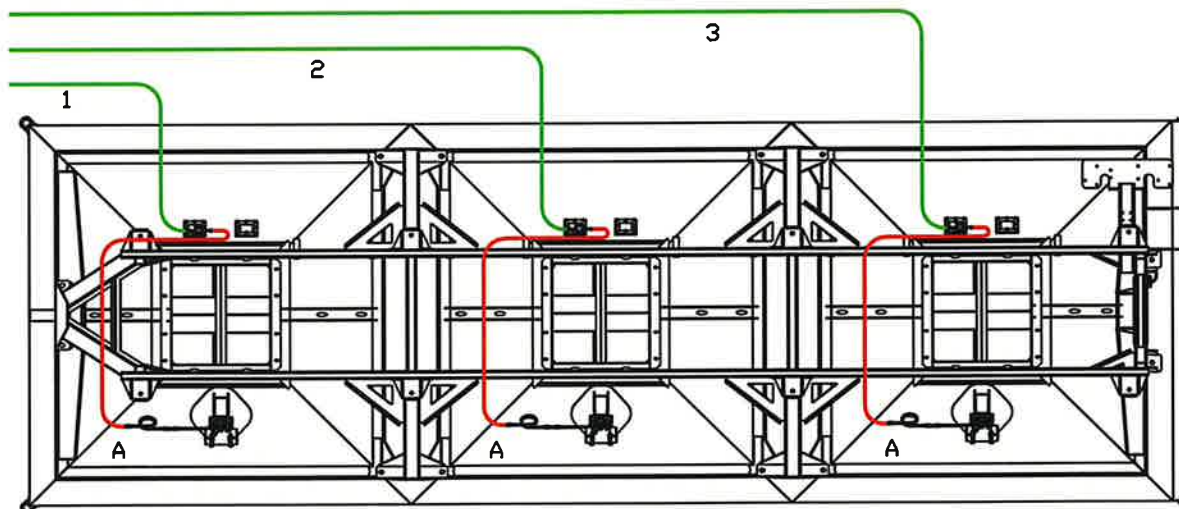

VIEW FROM BOTTOM OF THE BOX LOOKING UP

APPROXIMATE LENGTHS OF WIRE (735320 - 12 GA/2 TRAILER WIRE)

- 1 = 14'
- 2 = 22 1/2'
- 3 = 31'

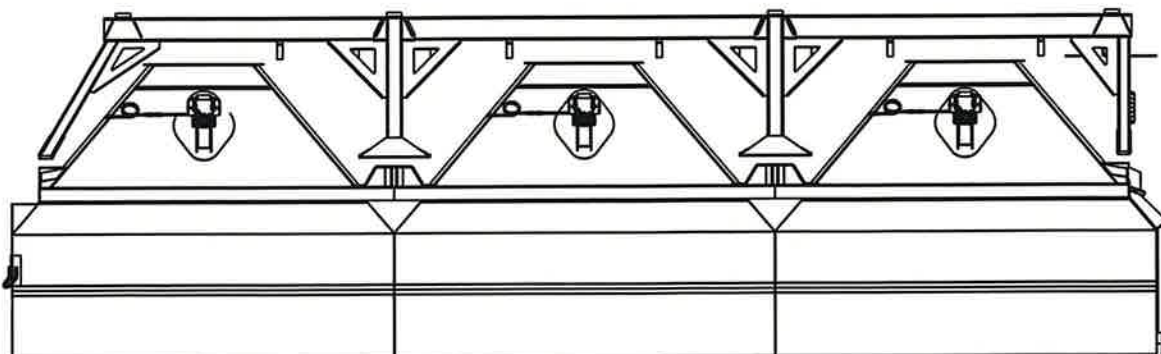

MT600 WITH VIBRATORS PARTS LIST (P/N: 4702DC700 LOOSE / 4702DC700A ASSEMBLED)

ITEM NO.	PART NUMBER	DESCRIPTION	QTY.
1	47076559	16 TON TENDER BOX	1
2	76737	VIBRATOR SWITCH PLATE	2
3	18476351	NUT HX SS 5/16 SELF LOCK	4
4	CG-100451	SWITCH (INCLUDED WITH VIBRATOR)	2
5	18704218	SCREW MACH RD PH SS 8-32 X 3/4 LG	8
6	18474201	NUT HX NYLOCK #8-32 SS	8
7	MDCV12-700-MM-96-06	VIBRATOR	2
8	195569-86	CORD EXTENSION 86" (INCLUDED W/ VIBRATOR)	2
9	735320	TRAILER WIRE 12 GA/2	2
10	18097540	BOLT, HEX CAP 1/2-13 X 4 1/2 LG GRADE 8 ZC	4
11	18851400	WASHER FLAT 1/2 SAE ZC	4
12	18457400	NUT, NYLOCK 1/2-13 GRADE 8 ZC	4
13	47007997	VIBRATOR MOUNT	2

REF. ONLY

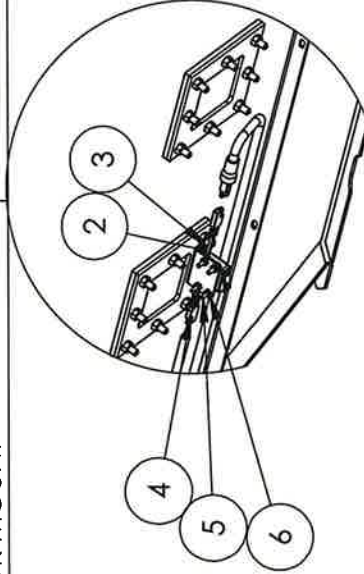
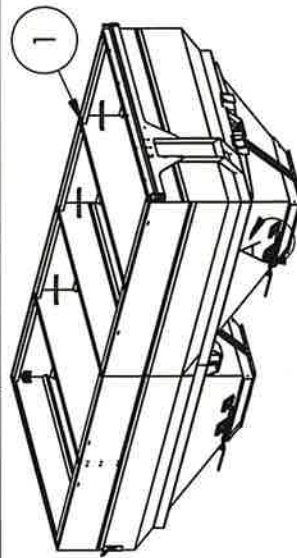

DETAIL A
2X TYP.

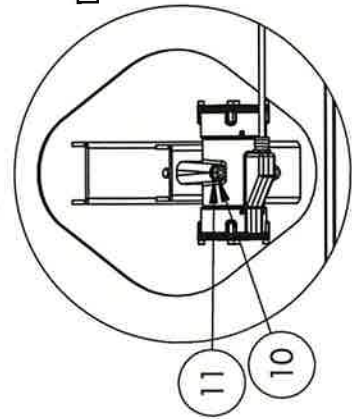
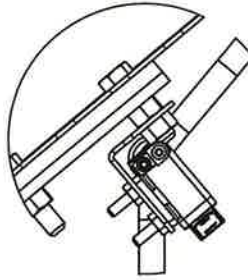

DETAIL B
2X TYP.

REPLACEMENT PARTS

CG-100454 - FUSE 20 AMP

735320 - 12 GA 2 WIRE- QTY 36 1/2'
(1- 14' / 1-22 1/2')

ALSO REQ'D BUT NOT SHOWN:

32504 - VINYL INSULATED RINGS - QTY 2

38262 - STEP DOWN BUTT CONNECTORS - QTY 2

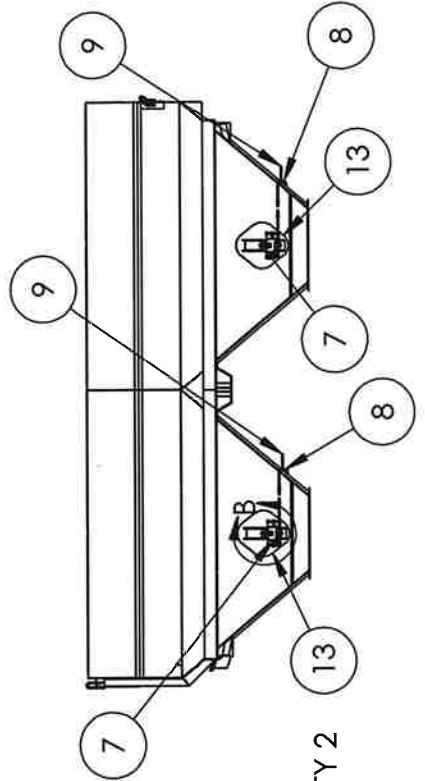

MT600 VIBRATOR WIRING DIAGRAM

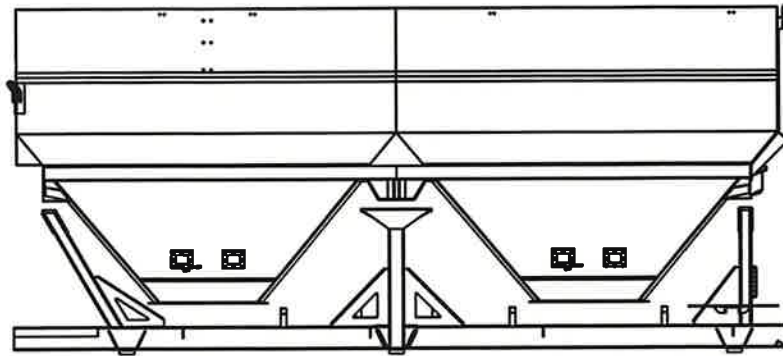

1. CABLES SHOWN IN MARKED "A", ARE PREASSEMBLED TO THE VIBRATOR
2. CUT THE PLUG END OFF THE END OF THE SWITCH HEADED TO THE BATTERY
3. ATTACH P/N 38262 (STEP DOWN BUTT CONNECTOR) TO SNIPPED END
4. INSERT CUT TO LENGTH WIRE INTO THE OPEN END OF BUTT CONNECTOR AND SEAL
5. REPEAT FOR ALL VIBRATORS
6. SEND P/N 32504 VINYL INSULATED RINGS LOOSE

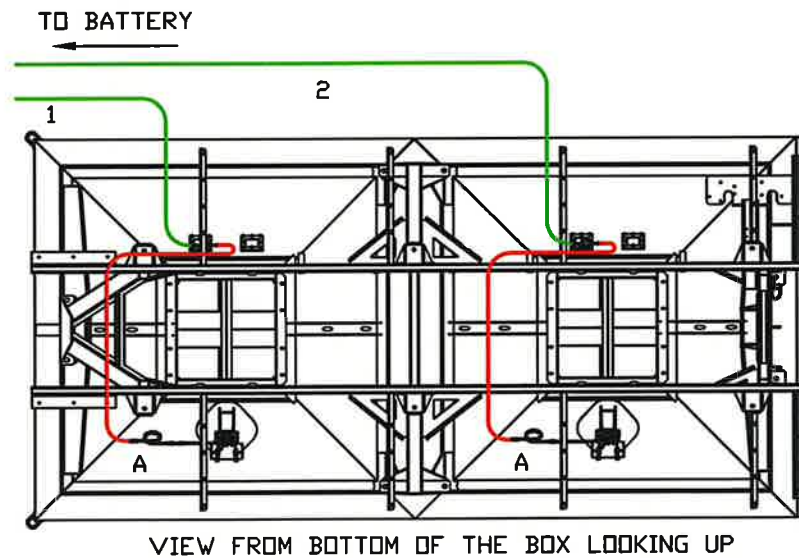

APPROXIMATE LENGTHS OF WIRE (735320 - 12GA/2 TRAILER WIRE)
1 = 14'
2 = 22 1/2'

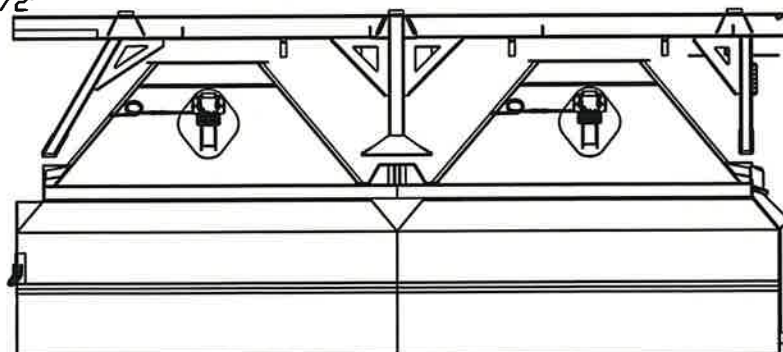

AUGER WARNING SYSTEM

PART #: 70660

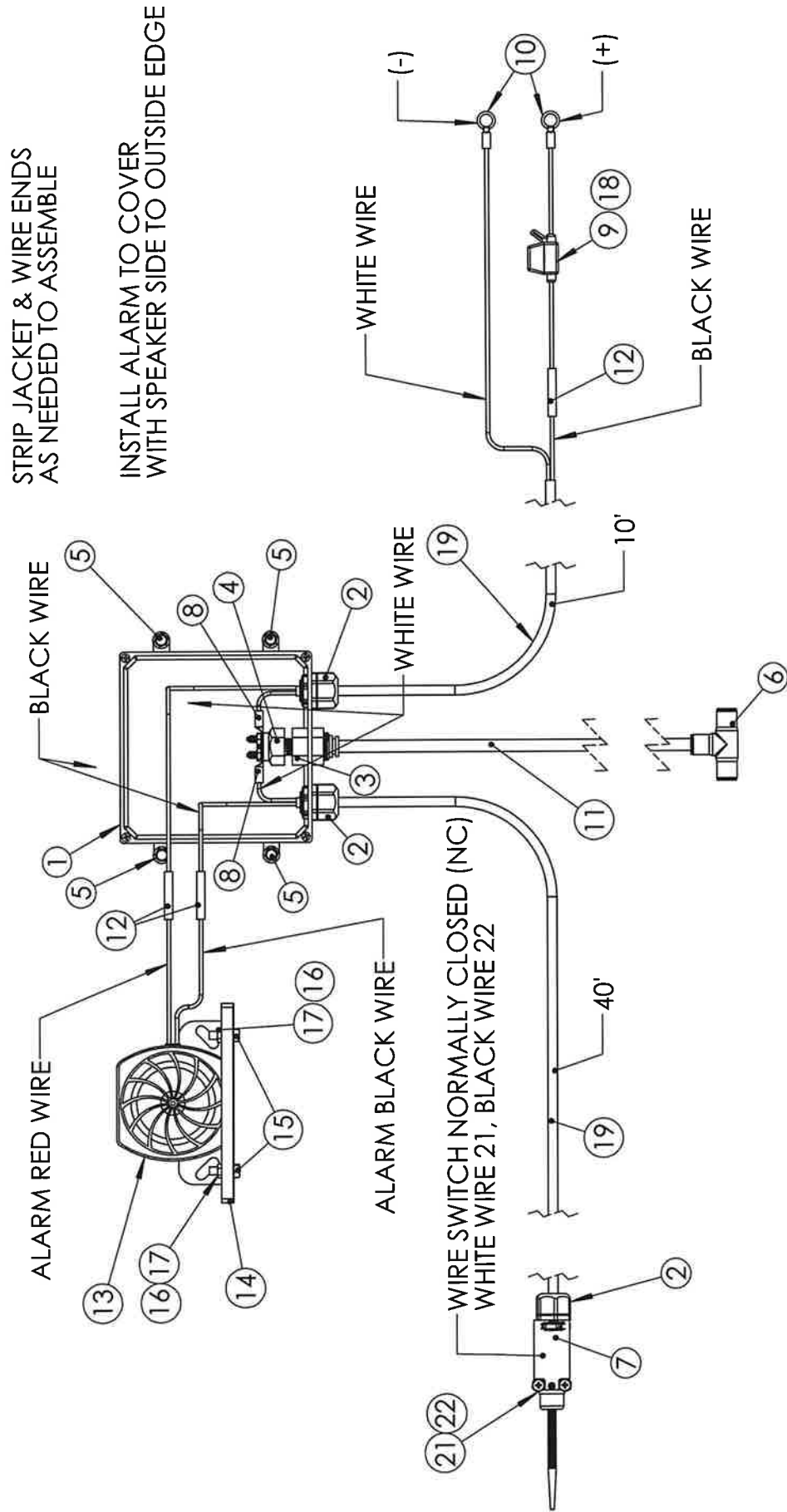

AUGER WARNING SYSTEM

PART #: 70660

ITEM NO.	PART NUMBER	DESCRIPTION	QTY.
1	70875	ALARM BOX	1
2	70878	CORDGRIP	3
3	70877	FEMALE BULKHEAD CONNECTOR WITH NUT	1
4	70876	STOP LIGHT SWITCH	1
5	70879	1/4" X 1" SELF TAPPING SCREW, SS, DRILL TIP	4
6	70880	UNION TEE, 3/8	1
7	70881	LIMIT SWITCH	1
8	70656	RING TERMINAL, HEAT SHRINK, 16-14 GA AND #10 SCREW SIZE	2
9	70882	IN LINE FUSE HOLDER	1
10	70883	RING TERMINAL, HEAT SHRINK, 16-14 GA AND 3/8" SCREW SIZE	2
11	70884	AIR BRAKE TUBING	8'
12	70886	SPLICE CONNECTOR, 16-14 GA, HEAT SHRINK	3
13	70887	ALARM	1
14	70875-2	ALARM BOX COVER (INCLUDED W/ ALARM BOX)	1
15	18055718	BOLT HX 1/4 X 3/4	2
16	18881001	WASHER FLAT 1/4 SS	2
17	18569200	NUT 1/4 NYLOCK SS	2
18	70888	FUSE, 7.5A	1
19	70885	PORTABLE CORD	50'
20	70658	ADHEASIVE BACKED CABLE TIE HOLDER, OUTDOOR	12
21	71043	NUT, NYLOCK, 10-24, SS	2
22	71044	SCREW, PAN HEAD, 10-24 X 1-3/4", SS	2
23	70659	CABLE TIE, 7-1/2" LONG, OUTDOOR	12

MT600TA AND MT900TA MOUNTING LOCATIONS

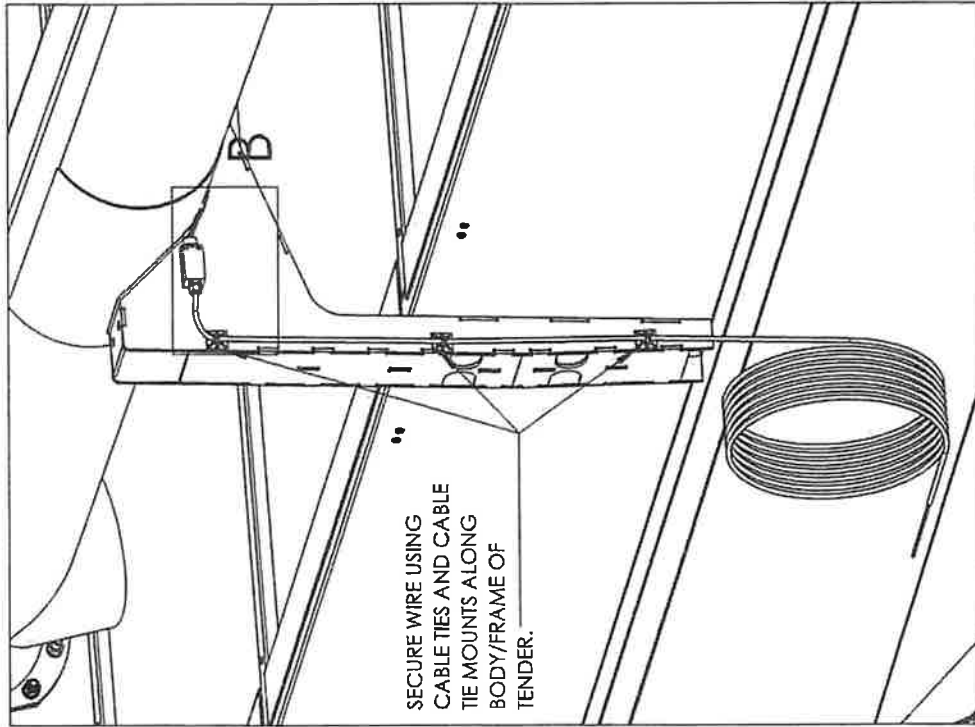

LOCATE SWITCH AS SHOWN ON AUGER CRADLE SO THAT TOGGLE ARM IS TRIGGERED WHEN AUGER IS SEATED IN CRADLE. AN AUDIBLE CLICK CAN BE HEARD WHEN THE SWITCH IS TRIGGERED.

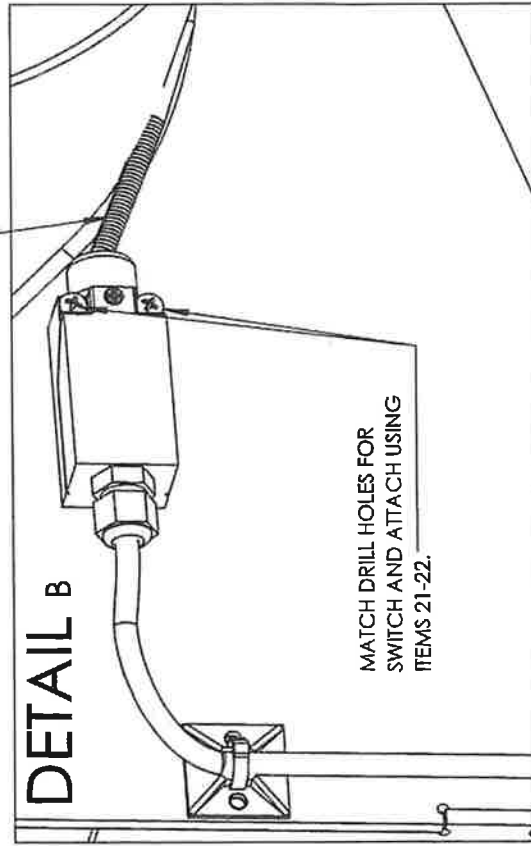

TRUCK MOUNT ASSEMBLY DETAIL

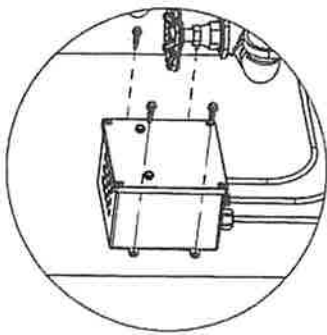

1. SECURE ALARM BOX USING 1/4" X 1" SELF TAPPING SCREWS TO BACK OF CAB IN APPROXIMATE AREA SHOWN.
2. CONNECT BATTERY LEADS TO BATTERY. THE BLACK WIRE GOES TO THE POSITIVE (+) AND THE WHITE WIRE GOES TO THE NEGATIVE (-) TERMINAL. SECURE WIRE AS NEEDED AND REMOVE SLACK.
3. ROUTE AIR LINE INTO THE TRUCKS FRAME RAIL AND SPLICE THE UNION TEE INTO THE YELLOW AIR LINE OF THE TRUCK. SHORTEN LINE BACK TO JUNCTION BOX AND SECURE AS NEEDED.
4. ROUTE LIMIT SWITCH ALONG FRAME OF TRUCK AND INSTALL PER THE MOUNTING LOCATIONS SHOWN ON PAGES 3-5 DEPENDING ON MODEL OF TENDER. SECURE WIRE AS NEEDED AND REMOVE SLACK.
5. START ENGINE OF TRUCK AND RAISE DISCHARGE AUGER OUT OF THE CRADLE. THE ALARM SHOULD SOUND WHEN THE AIR BRAKES ARE RELEASED.
6. LOWER DISCHARGE AUGER BACK INTO THE CRADLE AND RELEASE THE AIR BRAKES. THE ALARM SHOULD NOT SOUND.

DETAIL D

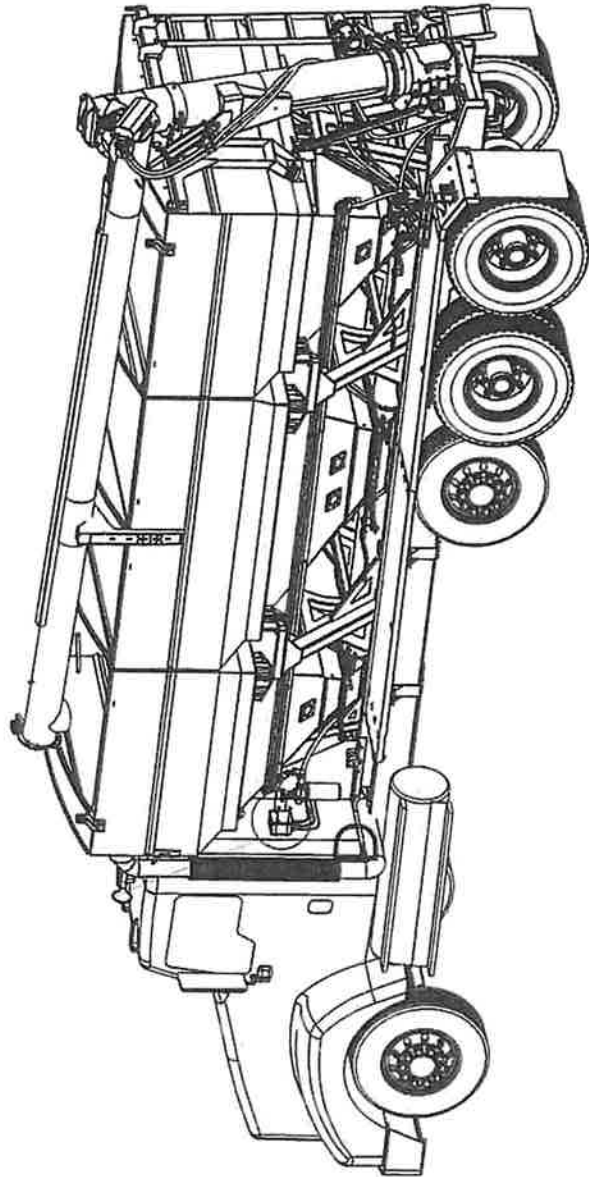

TRAILER MOUNT ASSEMBLY DETAIL

1. SECURE ALARM BOX USING 1/4" X 1" SELF TAPPING SCREWS TO THE TRAILER IN APPROXIMATE AREA SHOWN, ON FRONT DRIVER'S SIDE FENDER.
2. CONNECT BATTERY LEADS TO BATTERY. THE BLACK WIRE GOES TO THE POSITIVE (+), AND THE WHITE WIRE GOES TO THE NEGATIVE (-) TERMINAL. SECURE WIRE AS NEEDED AND REMOVE SLACK.
3. ROUTE AIR LINE INTO THE TRAILERS FRAME RAIL AND SPLICE THE UNION TEE INTO THE RED AIR LINE OF THE TRAILER. SHORTEN LINE BACK TO JUNCTION BOX AND SECURE AS NEEDED.
4. ROUTE LIMIT SWITCH ALONG TRAILER AND INSTALL PER MOUNTING LOCATION SHOWN ON PAGES 3-5 DEPENDING ON MODEL OF TENDER. SECURE WIRE AS NEEDED AND REMOVE SLACK.
5. START ENGINE AND RAISE DISCHARGE AUGER OUT OF THE CRADLE. THE ALARM SHOULD SOUND WHEN THE AIR BRAKES ARE RELEASED.
6. LOWER DISCHARGE AUGER BACK INTO THE CRADLE AND RELEASE THE AIR BRAKES. THE ALARM SHOULD NOT SOUND.

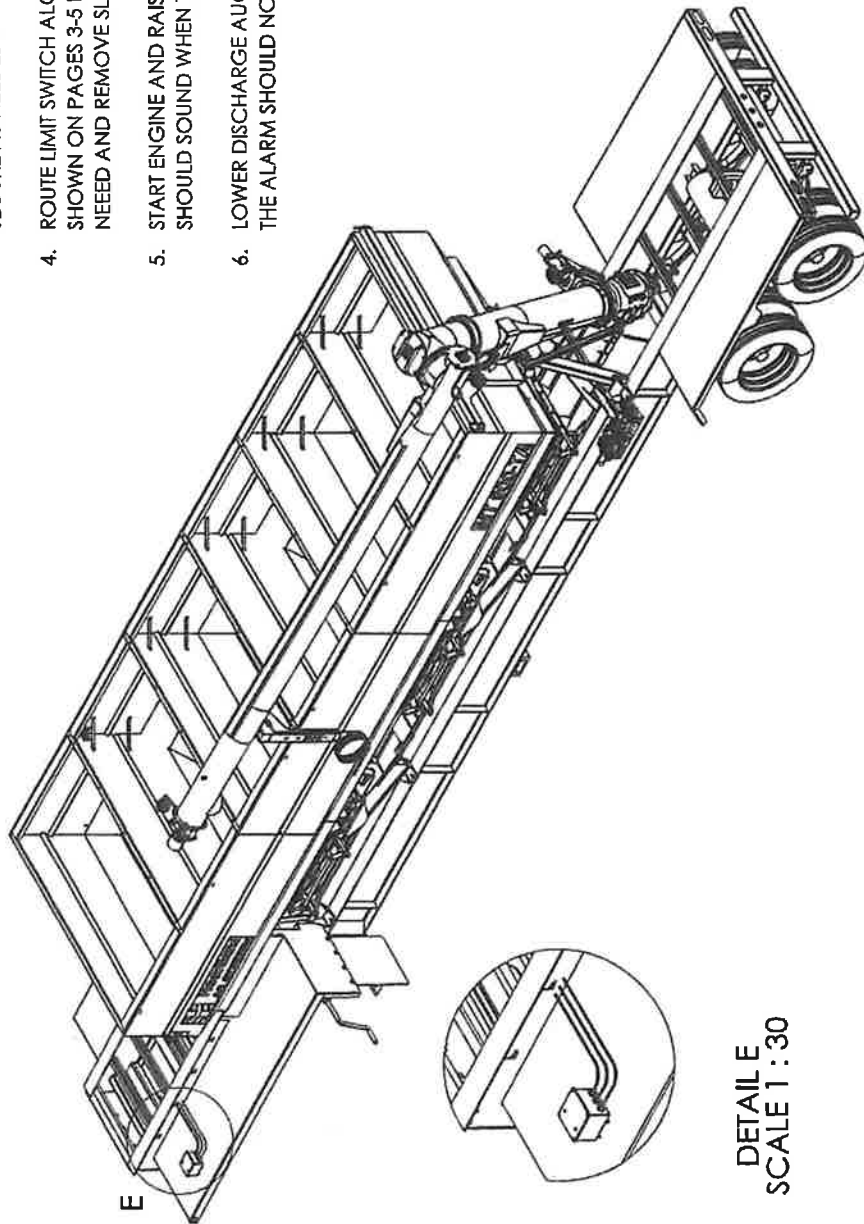

DETAIL E
SCALE 1 : 30

OPTIONAL BOLT ON POKE HOLE & FLUSH TUBE P/N: 71850

ITEM NO.	PART NUMBER	DESCRIPTION	QTY.
1	71849	POKE HOLE/FLUSH TUBE WELDT	1
2	200A	BANJO 2" CAM LEVER COUPLING, MALE ADAPTER FEMALE THREADS	1
3	200172	2" FEMALE COUPLER CAP	1

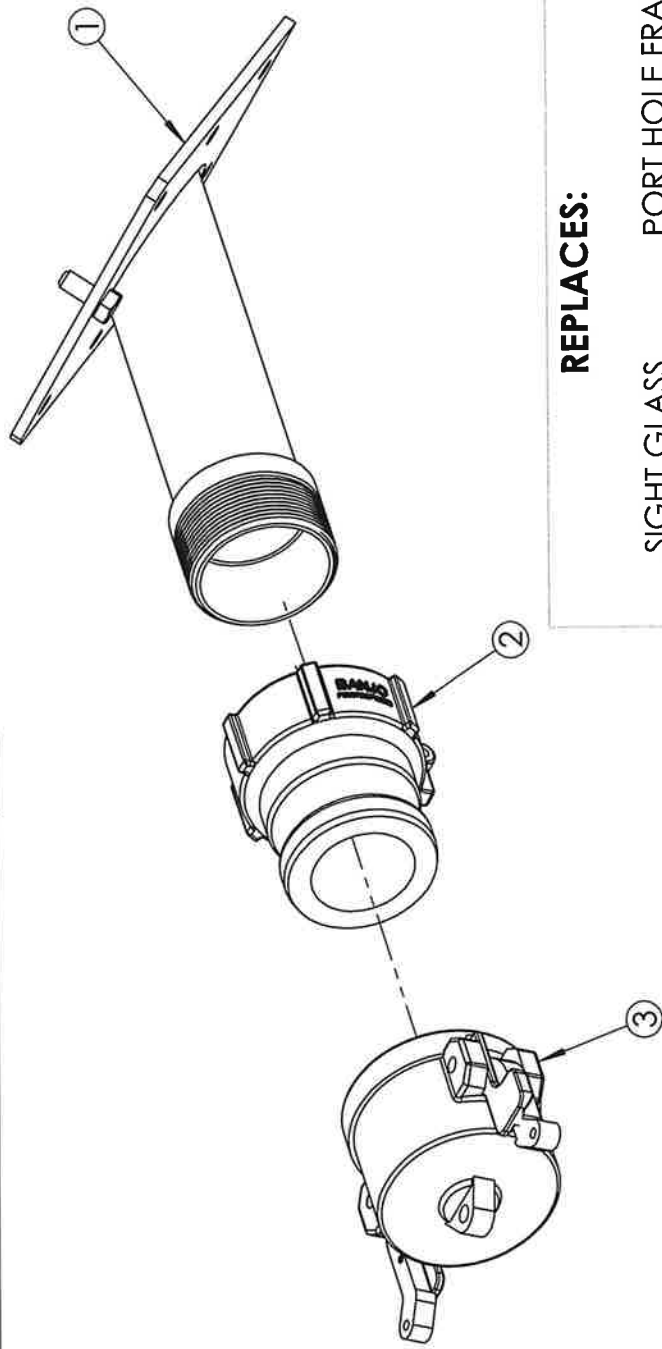

REPLACES:

SIGHT GLASS
P/N: 76608

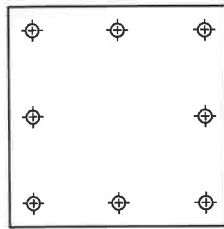

PORT HOLE FRAME
P/N: 76609

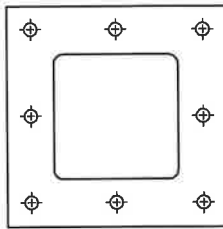

ORDER 1 PER WINDOW TO BE REPLACED

SECURE USING THE HARDWARE REMOVED FROM WINDOWS

((18026422 - BOLT CAP SS 5/16 X 1 - QTY 7 (8 WILL BE REMOVED))
((18476351 - NUT HX SS 5/16 SELF LOCK QTY 8))

