



MT 900-TA

165.08



Heartland
AG SYSTEMS
EQUIPMENT

Tenders + Spreaders

PRODUCT INFORMATION GUIDE

40.93
TRAILER TO
GROUND

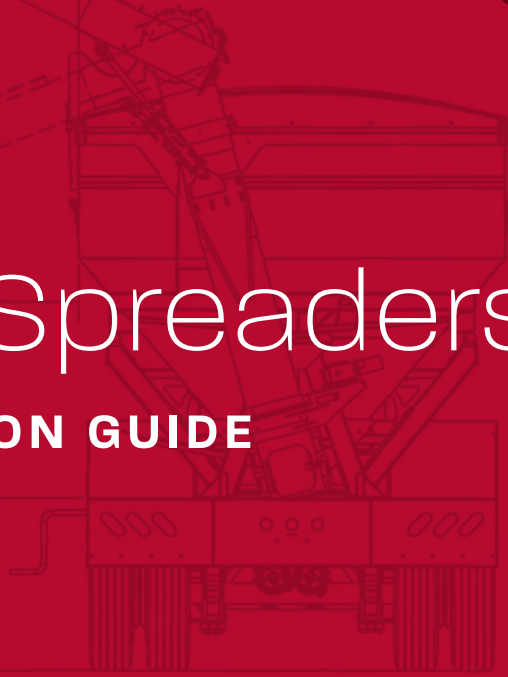

Tender Series

Tending to your bottom line.

When it comes to tight deadlines and maximizing productivity, every angle matters. MT-Series tenders from Heartland AG Systems features the most innovative design in the industry. Built for faster unload times, better product flow and enhanced safety, this line of tenders features up to 50° angled hopper bottoms, 270° swivel auger and 360° solutions you can rely on load after load.

*Smaller size available: for more information regarding the MT10, please contact your Heartland AG Systems Equipment representative.

Models:

VPA 1000

MT900-TA

MT700-TA

MT600-TA

1612

MT 32

MT 24

MT 16

MT 10*

- Unload Rates Up to 4,500 lbs. per Minute
- Self-Cleaning Bins
- 304 Stainless Steel Construction
- 50° Angled Hopper Bottom
- Low Center of Gravity
- 270° Swivel Auger
- Diesel Engine or Wet Kit
- Better Product Flow and Faster Unloading
- Product Viewing Windows to Easily See What's Happening inside
- Built Strong for Tough Road Conditions
- Extended Discharge Heights
- Less Maintenance, Lower Costs
- No Shoveling, Less Downtime

MT900-TA

- Top Unload 28 Ton Tender
- Struck Capacity: 900 cu. ft.
- 6 Compartments

MT700-TA

- Top Unload 21 Ton Tender
- Struck Capacity: 700 cu. ft.
- 4 Compartments

MT600-TA

- Top Unload 18 Ton Tender
- Struck Capacity: 600 cu. ft.
- 4 Compartments

Additional Options:

- Trailer Mounted or Truck Mounted
- Engine Driven or Hyd. Quick Coupler Pkg
- SRT Electric Roll Tarp
- Scale Package

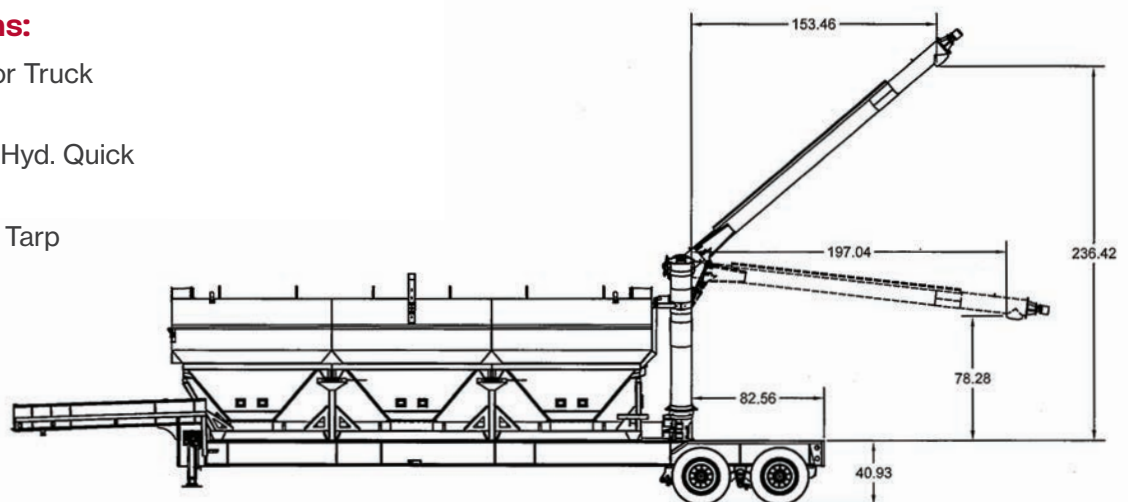



Meet the industry's first variable position auger system.

VPA 1000 Tender

- Side Unload 30-Ton Tender
- Patent Pending Variable Position Auger System Discharges and Folds into Cradle on Both Sides of Tender for More Functionality Than a Traditional Side Auger Tender.
- Dual Chute Auger Configured to Discharge Fertilizer to Driver Side or Ditch Side Based on Orientation of the Auger.
- Unload Rates of Over 5,000 lbs. per Minute
- Struck Capacity: 1,000 cu. ft.
- 6 Compartments
- Self-Cleaning Bins
- 304 Stainless Steel Construction
- 50° Angled Hopper Bottom
- Low Center of Gravity
- Quick-Attach Pit Dump System to Make Tender a Versatile Piece of Equipment.

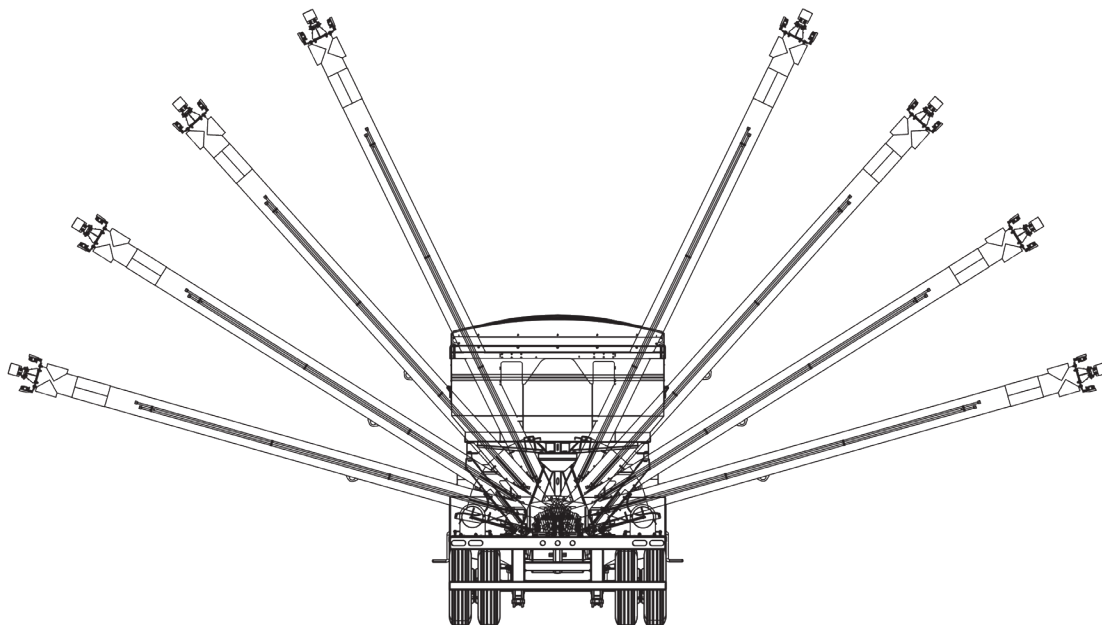



Maximum performance to move more product faster.

1612 Tender

16 Ton Rear Discharge Tender

- Unload Rates Up to 5,500 lbs per Minute
- Large Cleanout Door
- Struck Capacity: 500 Cubic Foot
- 409 or 304 Stainless Steel Construction
- 41° Side Slope
- 36° End Slope
- 2 Compartment Hopper
- 12" S.S. Discharge Auger
- Hydraulic Drive
- Tarp Options: Manual or Electric Roll
- 409 Stainless Steel Painted White
- Stainless Steel Slide Gates
- 21½' x 12" Stainless Tube & Screw
- Mud Flaps, S.S. Fenders, DOT Lights



Keep your operation moving forward with rugged durability and quality.

MT 16 Tender

A cost-effective tender solution designed to solve all of your bulk delivery problems.

- Unload Rates Up to 3,500 lbs. per Minute
- Large Clean-Out Doors Under Each Hopper
- Rear Clean-Out Door
- Unitized One-Piece Body Construction with 409 or 304 Stainless Steel
- 40° Hopper Bottom
- Low Center of Gravity
- Less Pump and PTO

Additional Features:

- Front and Rear Ladders
- Viewing Window
- Wiring harness with LED lights
- Hydraulic Folding and Raising Auger (Discharge 96 to 142 in. (244 to 361 cm) from Base)
- 8 in. (20 cm) Horizontal Unloading Auger to the 10 in. (25 cm) Rear Mounted-Side Unloading Auger
- Mud Flaps, S.S. Fenders, DOT Lights
- Optional: Hopper Vibrators, Stainless Steel Arched Divider

FEATURES	MT24	MT16	MT32
Capacity: cu. ft. (cu. meters.)	771 (21.8)	514 (14.55)	1,028 (29.1)
Body	Six separate 409 stainless hoppers with six individual control gates	Four separate 409 stainless hoppers with four individual control gates	Eight separate 409 stainless hoppers with eight individual control gates
Tare Weight: lbs. (kg)	4,500 (2041)	3,435 (1556)	6,870 (3116)
Auger Reach (Raised): in. (cm)	Min. Height discharge reach: 160" Max. Height discharge reach: 133"	Min. Height discharge reach: 160" Max. Height discharge reach: 133"	Min. Height discharge reach: 160" Max. Height discharge reach: 133"
Discharge Height (Raised) From Frame Base: in. (cm)	142 (361): 16 ft. (488 cm) auger	142 (361): 16 ft. (488 cm) auger	142 (361): 16 ft. (488 cm) auger
Base Dimensions: in. (cm)	34 x 292 (86 x 742)	34 x 196 (86 x 496)	34 x 396 (86 x 1005)
Body Dimensions: in. (cm)	96 x 288 (244 X 732)	96 x 192 (244 x 488)	96 x 388 (244 x 985)
Body Height: in. (cm)	81 (206)	81 (206)	81 (206)
Discharge Auger Size: in. (cm)	10 (25)	10 (25)	10 (25)
Horizontal Auger Size: in. (cm)	8 (20)	8 (20)	8 (20)
Bolt on Extensions: cu. ft.	142	95	190

Spreader Series

Built and assembled by the application experts.

The AG Spreader Series by Heartland AG Systems Equipment is designed for those who value safety and durability. Built for years of rugged use and the tough demands of fertilizer application, these spreaders meet the need with one-piece stainless-steel construction and adjustable wheel tracks. Spreading season can look different to every operation, so when you're looking for a compact solution to get the job done right, or provide your growers with a versatile and accurate do-it-yourself solution, look no further than the AG series.

Models:

AG X10

AG 800

AG 600

AG 500*

AG 400*

AG 800-HC

AG 600-HC

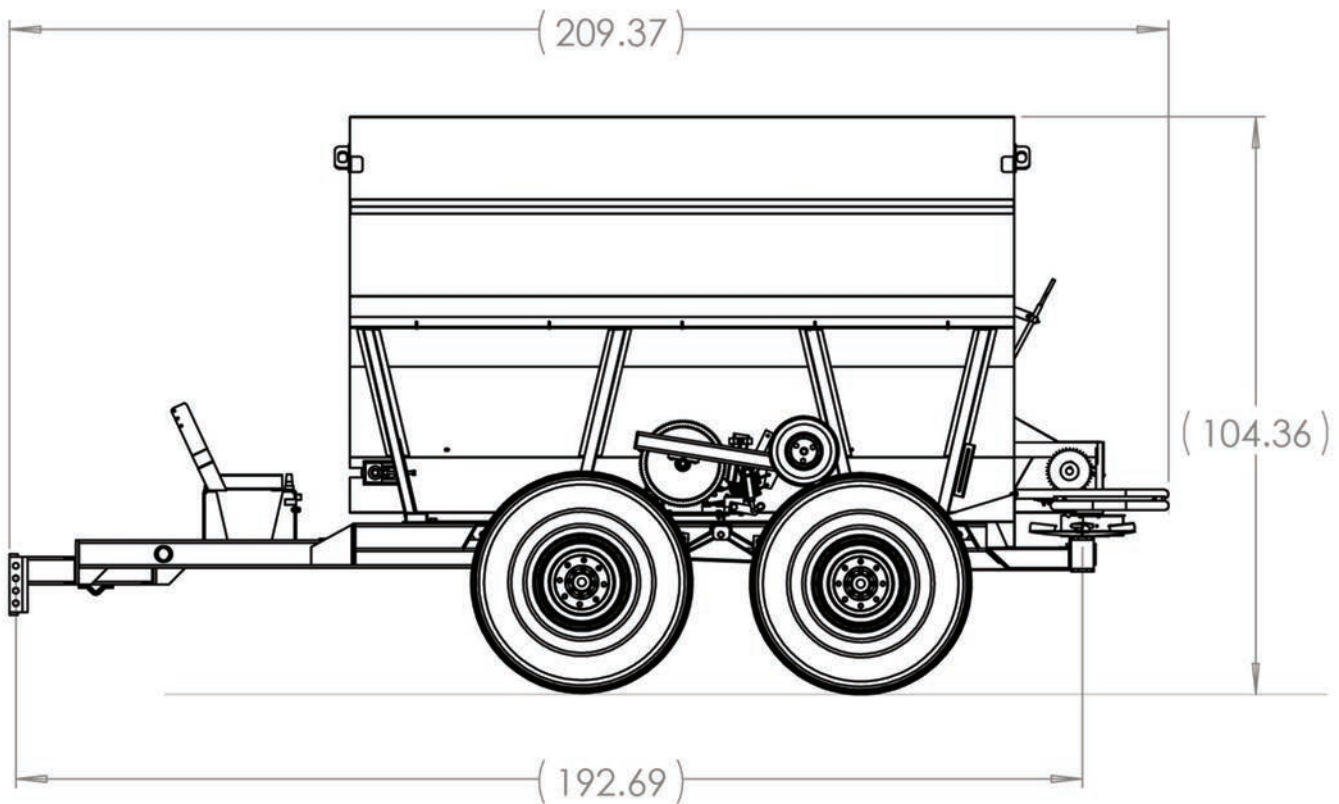

*Smaller sizes available:

For more information regarding the AG 500 and AG 400, please contact your Heartland AG Systems Equipment representative.



It doesn't get any easier than this.

Maximum flexibility with a smooth and efficient spread pattern.

AG X10

The AG X10 is an adjustable wheel track spreader that features a high-grade 304 stainless steel unitized one-piece body construction. Conveyor trough, metergate, rear skid section, gearbox mounts, line shaft shield and roller chains are also constructed of 304 stainless steel for longer durability.

- Capacity: 10 Ton (312 cu. ft.) Struck

- Stainless Steel Gearbox Mounts
- Two-Speed Conveyor Drive or 540/1000 RPM PTO Spinner Drive
- Your Choice of Single 24" or Dual 19" Distributor
- Heavy-Duty Hitch with Adjustable Clevis
- Stainless Steel Frame Fliptop, Roll Tarp with SS Fitted End Caps and Tarp Options
- Rope Trip Drive or Hydraulic Press Wheel Drive
- Standard 4-Wheel Surge Brakes
- 19L x 16.1 Tire or 11" x 22.5 Highway Tires
- Adjustable Wheel Track of 64" to 78"/ 72" to 88"
- Heavy-Duty 24,000 lb. Leaf Spring Suspension
- 14" Axle Clearance
- 24,000 lb. GVW
- High Clearance Option Also Available

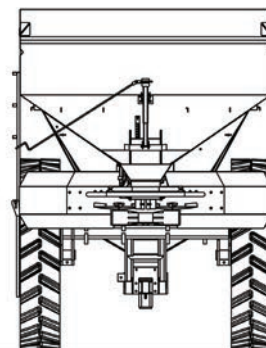
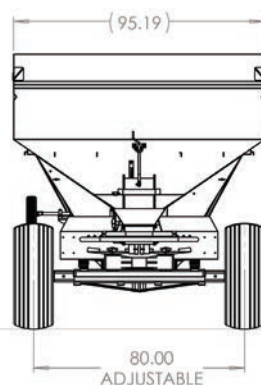
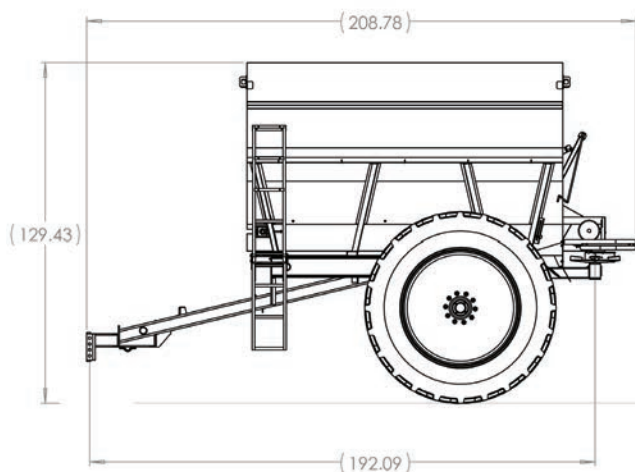



Heavy-duty durability, precise fertilizer application.

AG Series

Adjustable Wheel Track Spreader

Our adjustable wheel track spreaders provide years of rugged use. These spreaders feature a high-grade 304 stainless steel unitized one-piece body construction. Conveyor trough, metergate, rear skid section, gearbox mounts, line shaft shield and roller chains are constructed of 304 stainless steel for longer durability.

- Exclusive Design of Jig-Built Box and Trailer with Box Bolting to Trailer
- Stainless Steel Gearbox Mounts
- Two-Speed Conveyor Drive
- Your Choice of Single 24" or Dual 19" Distributor
- Heavy-Duty Hitch with Adjustable Clevis
- Stainless Steel Frame Fliptop or Roll Tarp, with SS Fitted End Caps, Options Available
- 540/1000 RPM PTO Spinner Drive Standard, with Gas-Engine, or Hydraulic Drive Optional
- Optional 11" x 22.5" Highway Tires (other options available upon request)

AG 800 Spreader

- Adjustable Wheel Track of 64" to 78"/ 72" to 88"
- Heavy-Duty 24,000 lb. Leaf-Spring Suspension
- 14" Axle Clearance
- Standard 4-Wheel Surge Brakes

AG 600 Spreader

- Adjustable wheel track of 60" to 78"/ 70" to 88"/ 69" to 90"
- Heavy-duty 16,000 lb. leaf-spring suspension
- 18" axle clearance

*Smaller sizes available: for more information regarding the AG 500 and AG 400, please contact your Heartland AG Systems Equipment representative.



Extended seasonal usage with optimal durability and even distribution.

AG HC Series

High Clearance Adjustable Wheel Track Spreaders

Our adjustable wheel track high-clearance spreaders feature 304 stainless steel box, conveyor trough, metering gate, rear skid section, gearbox mounts, line shaft shield and roller chains are constructed of stainless steel for longer durability.

- Exclusive Design of Jig-Built Box and Trailer with Box Bolting to Trailer
- Stainless Steel Gearbox Mounts
- Your Choice of Single or Dual Spinners
- 42" Axle Clearance
- 2-Wheel Brakes
- Hydraulic Engage press wheel drive or Hydraulic Conveyors drive with ISO control
- Stainless Steel Frame Fliptop or Roll Tarp, with SS Fitted End Caps, Options Available
- 540/1000 RPM PTO Spinner Drive Standard, with Gas-Engine, or Hydraulic Drive Optional
- Standard Sight Window & Optional Ladder

AG 800-HC Spreader

- 8 Ton (246 cu. ft.) Struck
- Unitized 304 Stainless Steel Box
- 10" SS Apron Chain
- 60' Spread Pattern
- 380/90R46 Tires and Rims
- Adjustable Wheel Track of 80" to 120"/ 88" to 144"
- Heavy-Duty 10 Bolt Hubs
- Heavy-Duty Pole Jack
- 20,000 lb. GVW

AG 600-HC Spreader

- Capacity: 6 Ton (175 cu. ft.) Struck
- 304 Stainless Steel Box
- Hydraulic Press Wheel Drive and Conveyor
- 320/85R38 Tires
- Adjustable Wheel Track of 80" to 120"/ 88" to 144"
- 4x4 Heavy-Duty Jack
- 16,000 lb. GVW

Application isn't just our business. It's our everything.

Heartland AG Systems Equipment is your total solutions provider of application support products and accessories tailored to meet the unique challenges of our industry. As a distributor and a manufacturer, we understand the application business and the importance of high quality, durable equipment that produces reliable application performance. Our industry-leading expertise and experience goes into every product we build:

- Tenders
- Fertilizer Spreaders
- Liquid Trailers
- Liquid Applicators
- Toolbars
- And more



We have your application business covered from every angle.

The Heartland AG Systems Equipment team has been working to make application equipment solutions faster, more reliable and safer since 1965. With complete focus on the application industry, our team works day in and day out to solve your toughest application needs so you can achieve the full potential every season brings.

Efficient

The unique design and engineering of Heartland AG Systems Equipment products delivers a complete portfolio of application solutions, resulting in maximum productivity for superior bottom line performance.

Reliable

With a reputation built on quality and durability, our products are made with heavy-duty performance to handle long days and tough conditions for the uptime your business demands.

Safe

Our advanced safety features were designed to provide better equipment solutions that are safer to operate. Safety is fundamental to a successful operation. Which is why, with everything we manufacture, you and your employees stay top of mind.

Our expertise goes the extra mile.

As the largest Case IH commercial application distributor, we have twelve locations across the upper United States from which we sell and service our application products.

- Ames, IA
 - DeForest, WI
 - Garrison, ND
 - Grand Island, NE
 - Great Bend, KS
 - Manvel, ND
 - Marshall, MO
 - Mitchell, SD
 - Moses Lake, WA
 - Burley, ID
 - Great Falls, MT
 - Hutchinson, MN
- » Corporate Office
» Manufacturing Plant

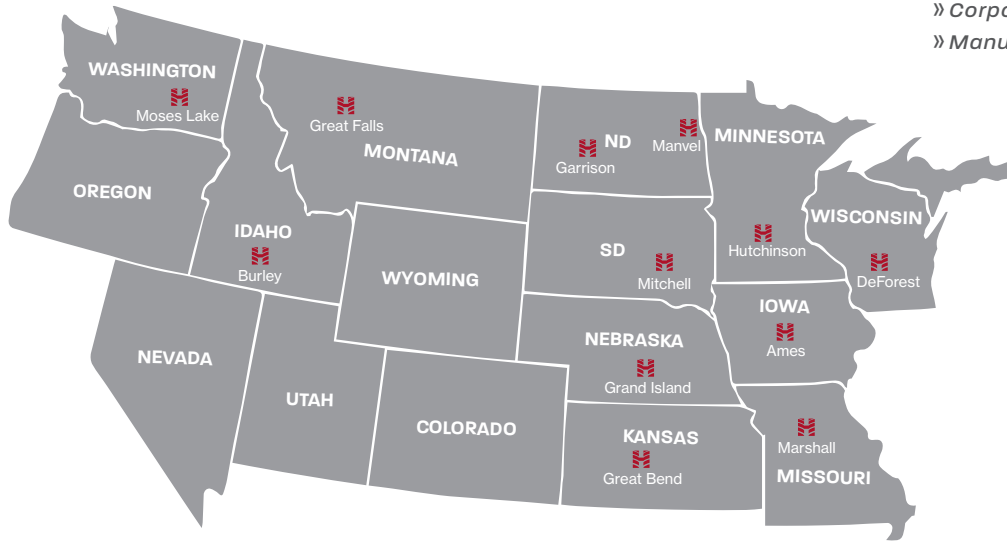

Every day at Heartland AG Systems, our employees commit to solving your toughest application challenges, all while protecting your uptime. This commitment is what enables us to bring the best possible application equipment, products and services to our customers. When you need informed real-time application solutions, we are the only partner you need.





We are application.



HeartlandAG.com
Corporate Office &
Manufacturing Plant
1180 MN-7
Hutchinson, MN 55350
(800)-328-5866

Ames, IA
(800) 779-7979
DeForest, WI
(800) 523-2350
Marshall, MO
(800) 889-6161

Grand Island, NE
(800) 445-9110
Great Bend, KS
(800) 652-9290
Manvel, ND
(800) 582-4269

Garrison, ND
(888)483-7669
Mitchell, SD
(800) 995-1943
Burley, ID
(800) 334-9120

Moses Lake, WA
(800) 996-2863
Great Falls, MT
(800) 452-0010

©2021 Heartland Agriculture, LLC
dba Heartland AG Systems. All Rights
Reserved.